

RUSTICA

INSTALLATION
INSTRUCTIONS

LOW
CLEARANCE

BYPASS
SYSTEM

FACE MOUNT
HANGERS



CONGRATULATIONS ON YOUR DECISION TO BRING HOME
AN AMERICAN MADE PRODUCT OF THE HIGHEST QUALITY

1-800-891-8312
support@rustica.com
www.Rustica.com

DESIGNED AND CRAFTED ENTIRELY IN THE

U.S.A.



DON'T BE A STRANGER
FOLLOW US ON SOCIAL MEDIA



HANGER Parts and Recommended Tools

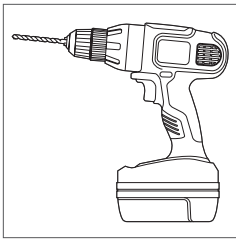

Drill with 1/8", 1/4", and 3/8" Drill Bits, 1-1/8" Forstner Bit or 1-1/8" Spade Bit and Phillips Bit

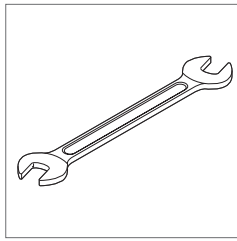

9/16" and 5/8" Combination Wrench

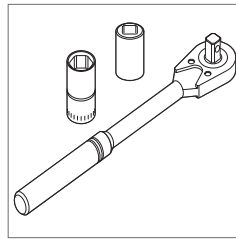

Socket Wrench with 9/16" and 5/8" Sockets

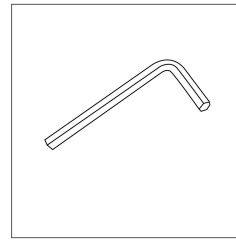

7/32" Allen Wrench

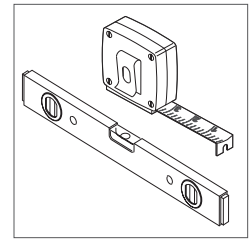

Tape Measure & Level

IMPORTANT:

The following instructions are for **LOW CLEARANCE** systems only. Do not attempt to use on flat, tube, bypass or ceiling mount track systems.

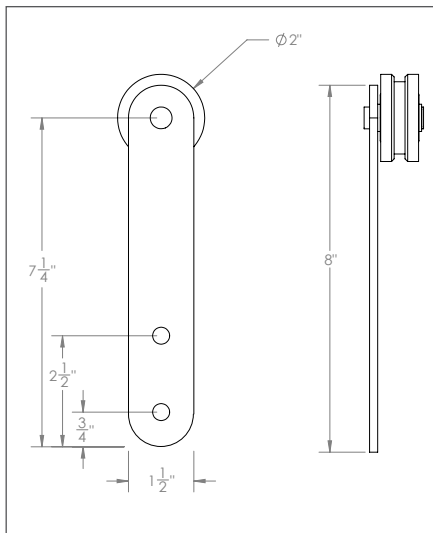

PARTS

- Ø Hanger Assembly (typically 1)
- Ø Lag Screws (typically the same amount as the number of holes in the track)
- Ø Allen Wrench Button Bolts (2 per hanger)
- Ø Phillips Screws (2 per guide & 2 per Anti-Jump Bracket or 1 per Anti-Jump Block)
- Ø 1" Washer (1 per track hole and 2 per Hex Bolt kit)
- Ø Anti-Jump Bracket (1) or

- G. Anti-Jump Blocks (1, only for bi-parting doors)
- H. DoorGuide (G)
- I. Hex Nuts (2 per hanger)
- J. Adjustable Stops (4)
- K. Track Brackets (quantity depends on track length)
- L. Track

Actual Hanger Style Will Vary

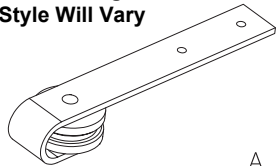

A.

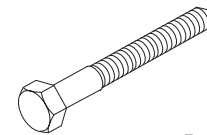

B.

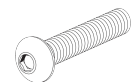

C.

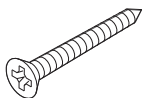

D.

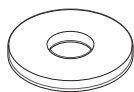

E.

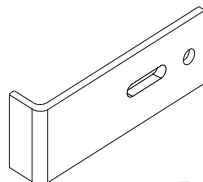

F.



G.

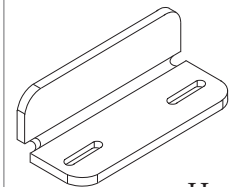

H.



I.

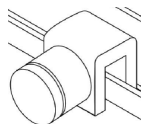

J.

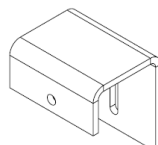

K.

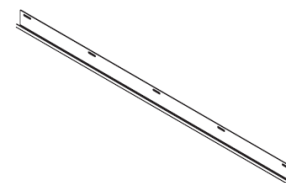

End View

L.



HANGER Assembly Instructions

IMPORTANT:
Doors using a Floor Mount Door Guide will have a groove on the bottom. Ensure this groove is on the opposite end of the door hanger installation

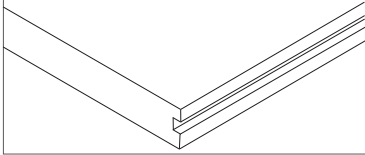

HANGER INSTALLATION

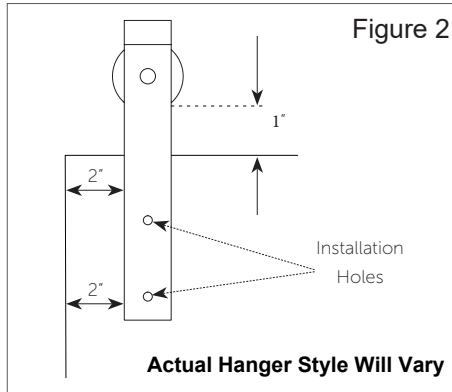
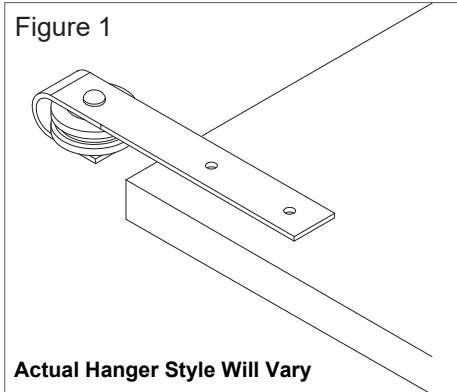

NOTE:
Hanger position, as indicated, is standard. If needed, you can install the hangers in a different position and use the adjustable stops to modify where the door will stop on the track.

1. Lay the door with the front facing up on a flat level surface.
 2. Place the hanger on the door (Figure 1).
 3. Adjust the placement of the hanger for a 1" gap between the top of the door and the bottom of the wheel. Ensure the side of the hanger at the top of the door is resting 2" from the edge of the door (Figure 2).
 4. Mark the center of each installation hole with a pencil (Figure 2).
 5. Repeat steps 2-4 for the opposite end of the door and set the hangers aside.
 6. Drill two pilot holes all the way through the door for each hanger using a drill with an 1/8" drill bit (Figure 3).
 7. Turn the door over and using a 1-1/8" Forstner bit*, drill a 3/8" deep hole into each pilot hole (Figure 4).
 8. Turn the door over, returning it to the face-up position. Drill all the way through the pilot holes using a drill with a 3/8" drill bit (Figure 5).
 9. Install the hangers to the front of the door using the button head bolts, washers and nuts provided (Figure 6).
Note: If you system shipped with acorn style nuts the bolt inserts from the back with the acorn on the front.
- * A 1-1/8" spade bit may be used in place of a Forstner bit.

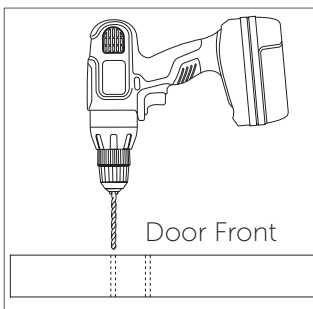

Figure 3

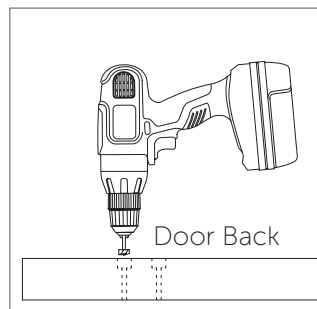

Figure 4

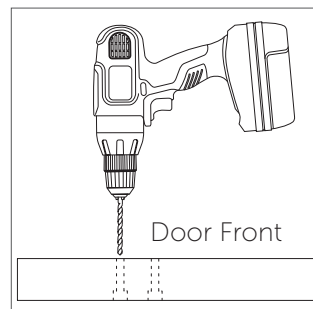

Figure 5

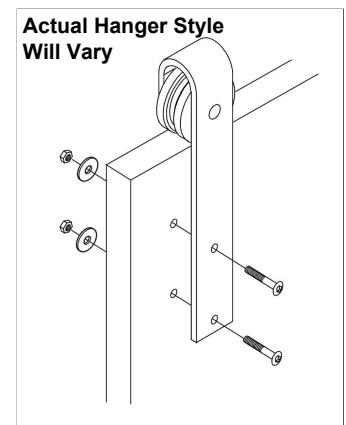

Figure 6



FLAT TRACK Assembly Instructions

Use teamwork. We recommend two people for this build.

FIRST THINGS FIRST

Check to see if the floor below the track area is level. If the floor is not level and rises more than 1/2" the door may rub or not slide properly. If the floor is not level, measure from the highest point of the floor surface to the recommended track placement and adjust track placement accordingly. Ensure the track will be installed into wall studs, wood backing in the wall or a header board that is installed into wall studs.

Installation instructions for the track are on the following page. Due to the unique and innovative engineering of this Low Clearance Bypass System we have included these larger details images of what a final installation will look like.

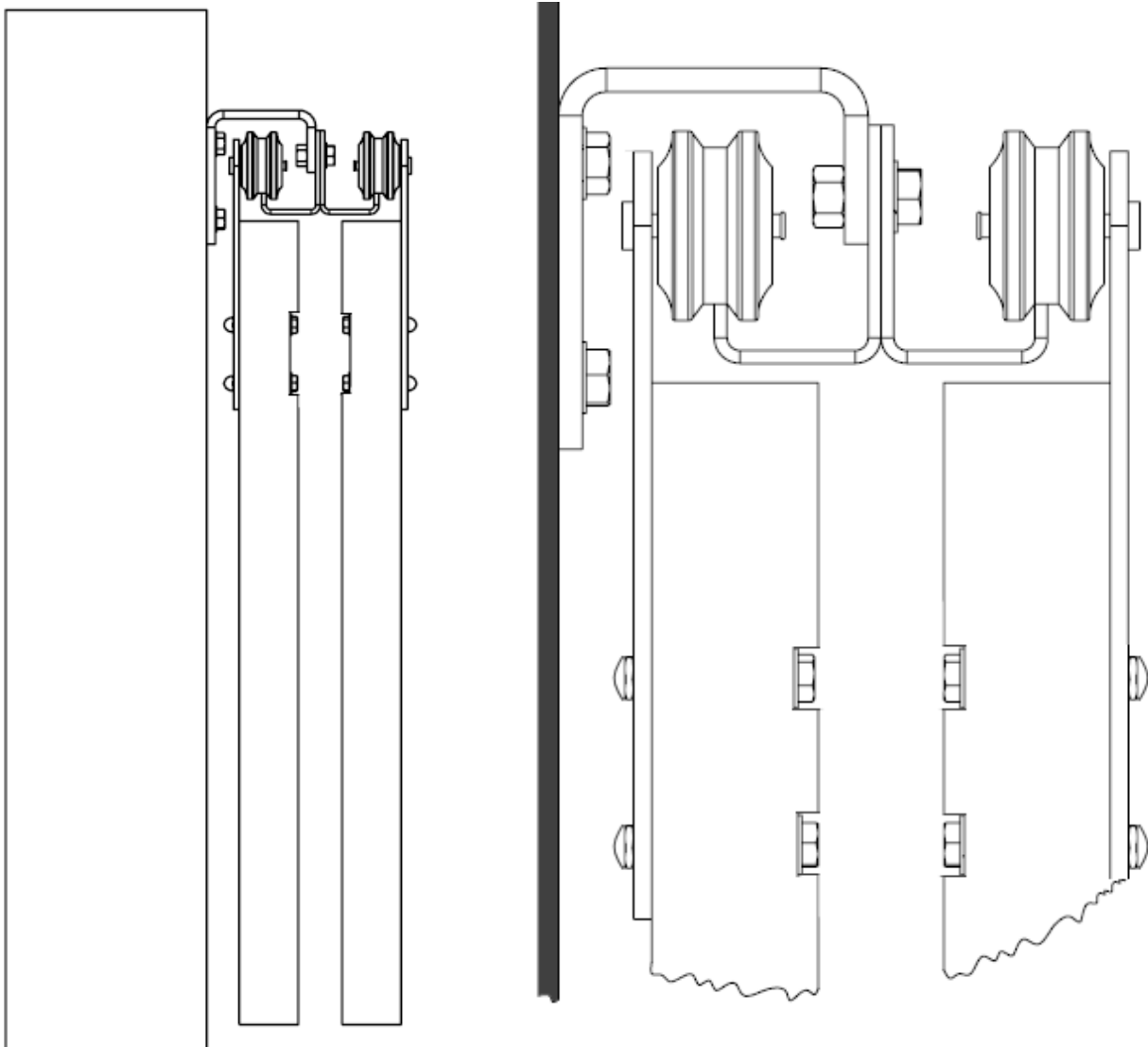

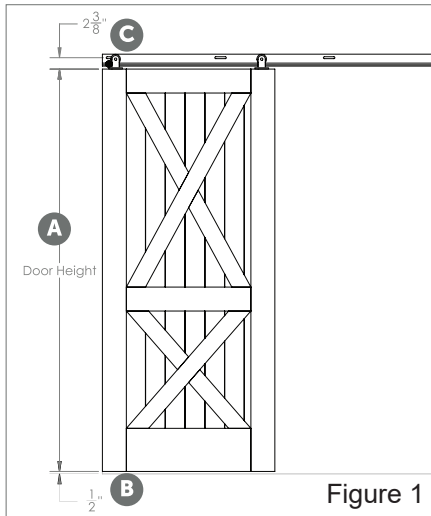

Figure 1

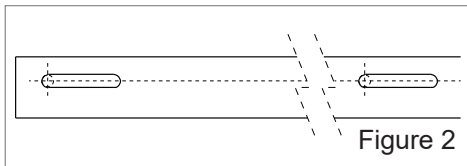

Figure 2

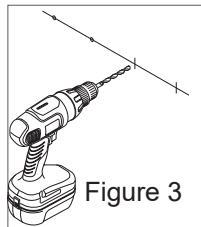

Figure 3

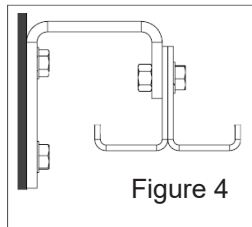

Figure 4

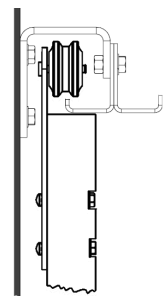

Figure 4

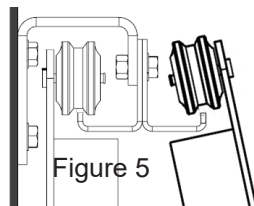

Figure 5

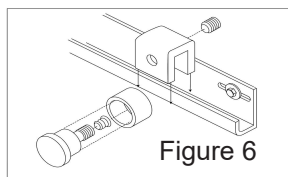

Figure 6

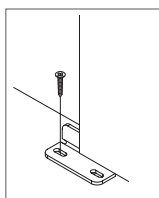

Figure 7

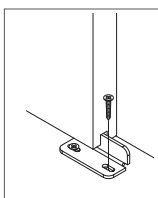

Figure 8

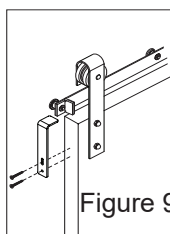

Figure 9

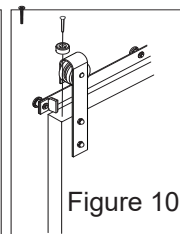

Figure 10

Actual Hanger Style Will Vary

TRACK INSTALLATION

1. To determine where the track brackets and the track should be installed (Figure 1), first measure the height of the door (A), then add 2-7/8" to the door length. 1/2" will be for the clearance between the bottom edge of the door and the floor (B). 2-3/8" will be from the top edge of the door to the center of the hole in the track and the track brackets (C).
2. Using a level and a pencil, mark a line above the doorway the same length as the track at the indicated height (door + 2-7/8").
3. Hold the track up to where the pencil line is visible through the holes in the track.
4. SUGGESTION: Use pieces of double stick tape on the back of the track to help hold the track in place while completing steps and .
5. Mark an intersecting line inside each slotted hole wherever they work best for your wall considering stud locations (Figure 2).
6. Take the track down, remove double stick tape (if used) and set the track aside.
7. Drill out the marked holes using a drill with a 1/4" drill bit (Figure 3).
8. Taking one bracket at a time, attach it to the wall (into the stud or header) with one lag screw and washer, 1/2 inch from the top of the slotted hole. The slotted hole allows for additional leveling as the each brackets is installed with 1 lag and washer. Once leveled, drill a second hole 1/2" from the bottom of the slotted hole and install a second lag and washer per bracket.
9. Once all brackets are securely installed and level, take tracks (back to back) and installed them with the 1" bolt washer and nut into each bracket (Figure 4).
10. Carefully set the door closest to the wall with the hangers facing the wall up, over and onto the track (Figure 5)
11. Carefully, and at a slight angle, lift the door furthest from the wall slightly over the track and then down onto it (Figure 5).
12. Slip the Adjustable Door Stops over each of the track at the ends where you want the doors to stop and tighten (Figure 6).

DOOR GUIDE INSTALLATION

1. With the door in the closed position, ensure the door is hanging straight using a bubble level.
2. Position the Door Guide part way into the groove in the bottom of the door (Figure 7).
3. Install the Door Guide using a 1" Phillips screw (provided) and a drill with a Phillips bit.
4. Slide the door toward the open position until the other side of the Door Guide is exposed.
5. Install the second 1" Phillips screw (provided) using a drill with a Phillips bit (Figure 8).

ANTI-JUMP GUIDE INSTALLATION

1. Place the Anti-Jump bracket on the door side, moving the bracket up until it is between 1/8" and 1/16" from the bottom edge of the rail. Mark the placement with a pencil. *
2. Install the bracket to the door edge with 2 Phillips screws(provided) using a drill with a Phillips bit (Figure 9).
3. Repeat steps 1 and 2 for the opposite end of the door.
OR
4. Place the Anti-Jump block on the top of the door (Figure 10). Using a drill with a Phillips bit, install the block with the 1" Phillips screw (provided).
5. Repeat step 4 for the opposite end of the door.

