

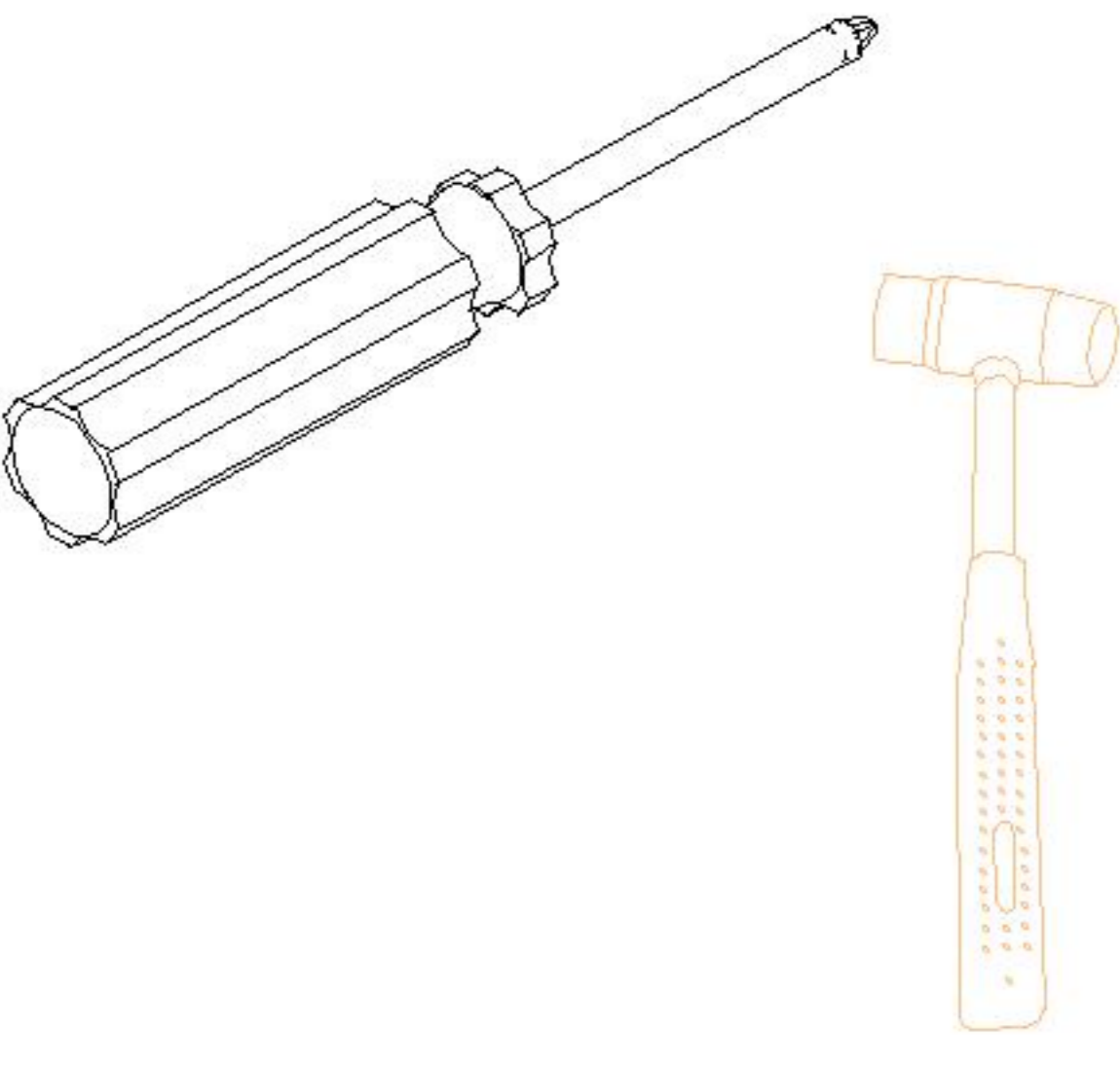

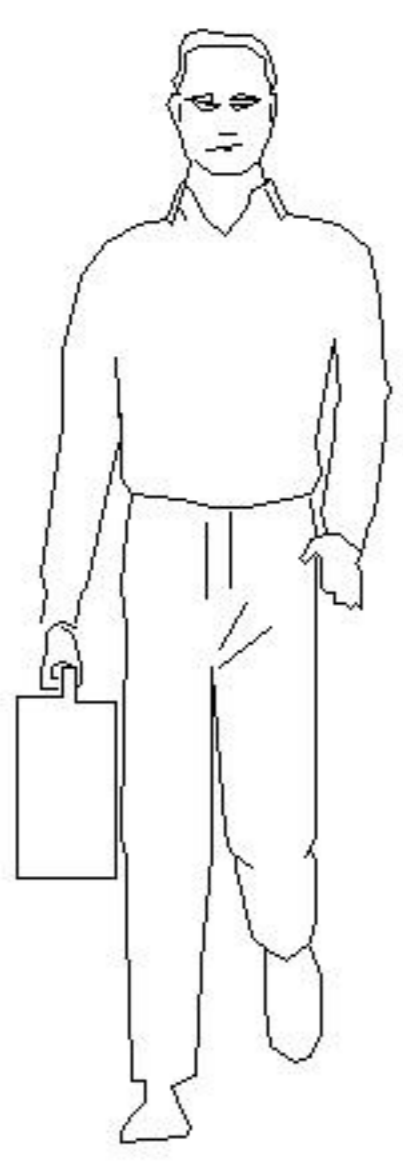

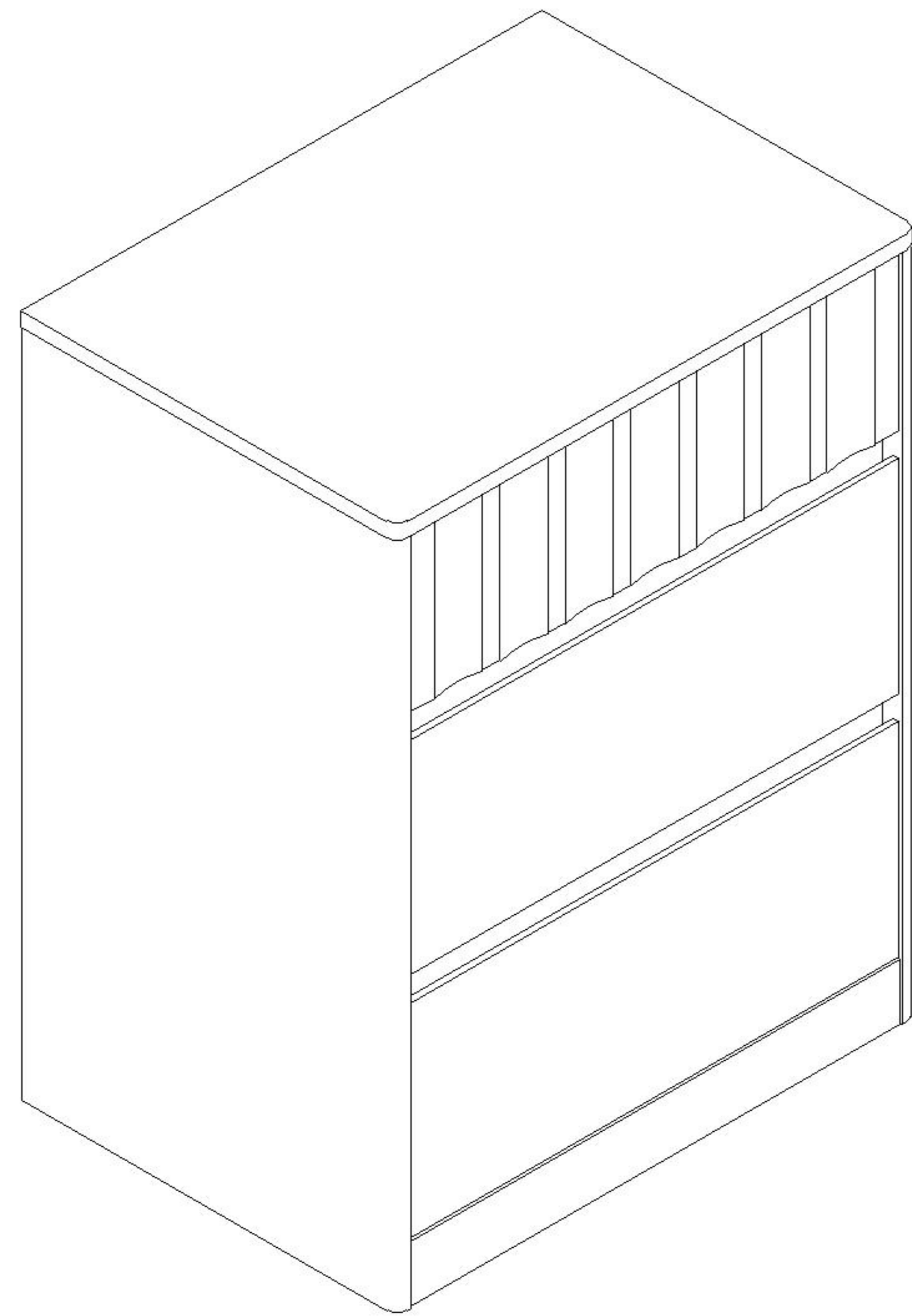
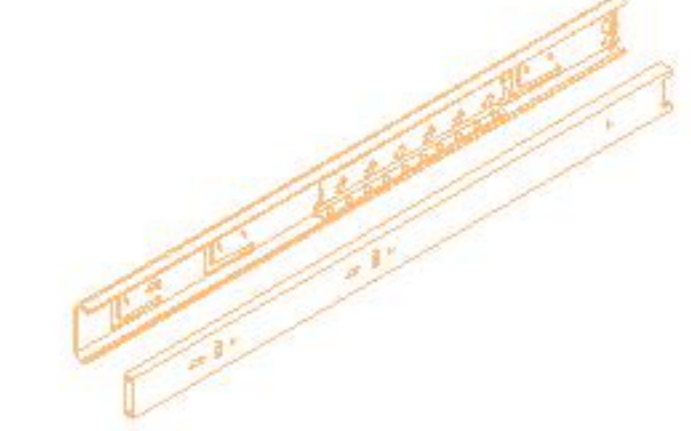
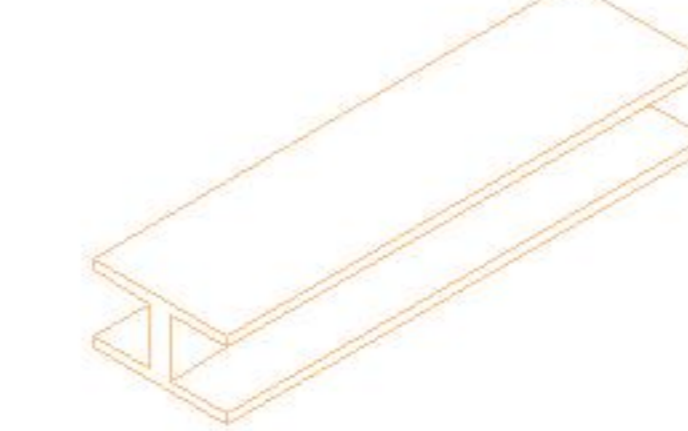
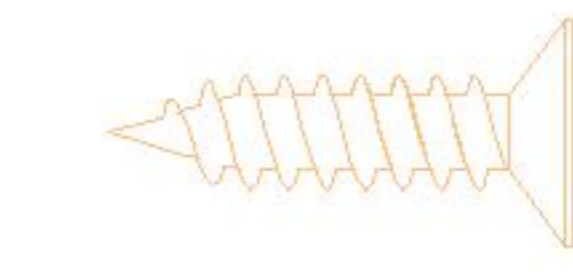
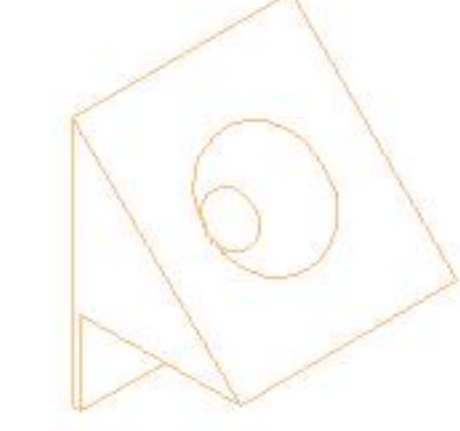
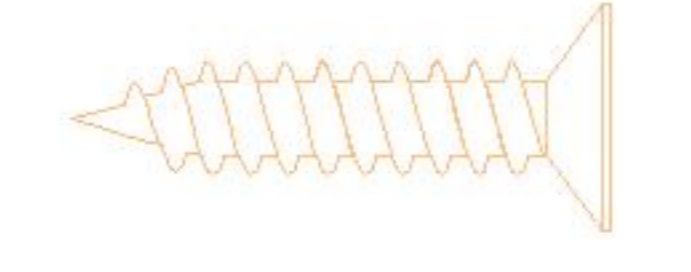
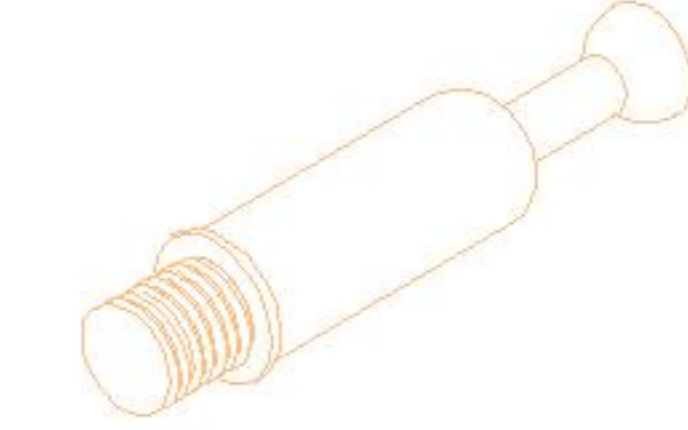

### 安装示意图/Assembly Instruction

产品名称 Model NO.	PM1E-A
产品规格 Specification	574*391*714mm
安装工具 Tool	安装人数 Installer
	

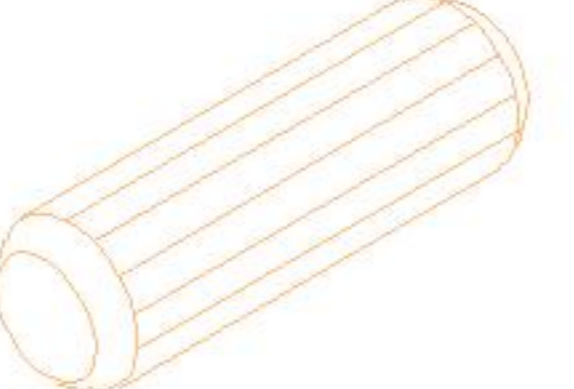
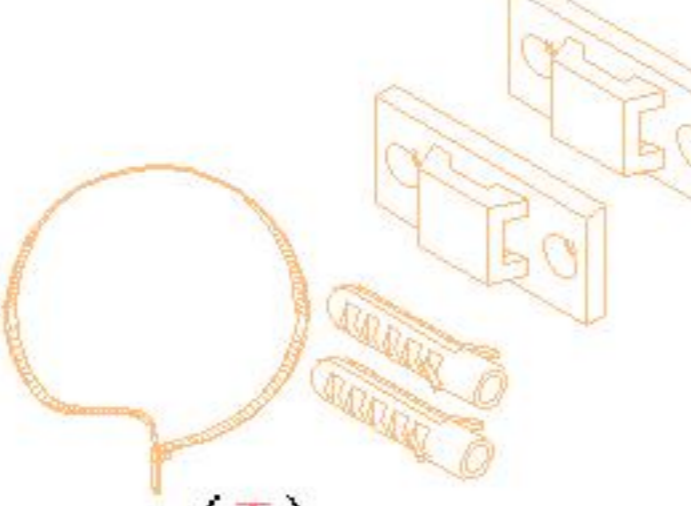

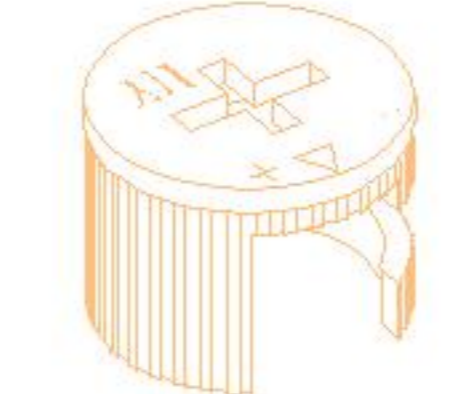
 (A)* 3 三节滚珠导轨-10" three-section ball rail	 (B)* 1 夹板条-白色 Backplane slot - white	 (C)* 38 自攻螺丝M3.5x12mm Self-tapping screw	 (D)* 8 背板扣 Back Plate Buckle-White
 (E)* 8 自攻螺丝M3.5x16mm Self-tapping screw	 (F)* 21 二合一螺杆 2-in-1-screw	 (G)* 21 大三合一锁饼 Three-in-one large lock	 (H)* 4 木榫Ø8x30mm wood tenon
 (I)* 1 家具防倒器-白色 Anti-fall device white	 (J)* 8 灰色毛毡脚垫 Footrest - Grey	 (K)* 13 小二合一杆 small two-in-one rod	 (L)* 13 小三合一锁饼 small three-in-one lock
 (M)* 13 塑料螺母 Plastic Nut	 (N)* 13 自攻螺丝M4x40mm Self-tapping screw		

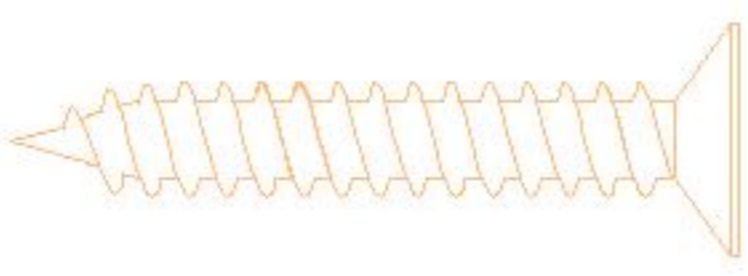
编号NO.	名称Name	规格 (mm) Specification	数量 QTY	材质Material
①	面板 Top panel	574*391*15	1	人造板WBP
②	右侧板 Side board(R)	696*390*15	1	人造板WBP
③	左侧板 Side board(L)	696*390*15	1	人造板WBP
④	前拉条 Front brace	542*58*15	3	人造板WBP
⑤	下拉条 Bottom brace	542*66*15	1	人造板WBP
⑥	背板 Back board	640*275*5	2	人造板WBP
⑦	下抽屉面板 Bottom drawer's panel	538*212*18	2	人造板WBP
⑧	抽屉右侧板 Drawer's side board(R)	295*110*12	3	人造板WBP
⑨	抽屉左侧板 Drawer's side board(L)	295*110*12	3	人造板WBP
⑩	抽屉后板 Drawer's Back board	492*110*12	3	人造板WBP
⑪	抽屉底板 Drawer's Bottom board	502*291*5	3	人造板WBP
⑫	上抽屉面板 Upper drawer's panel	538*159*18	1	人造板WBP

PM1E-A

安装方法/  
Installation method

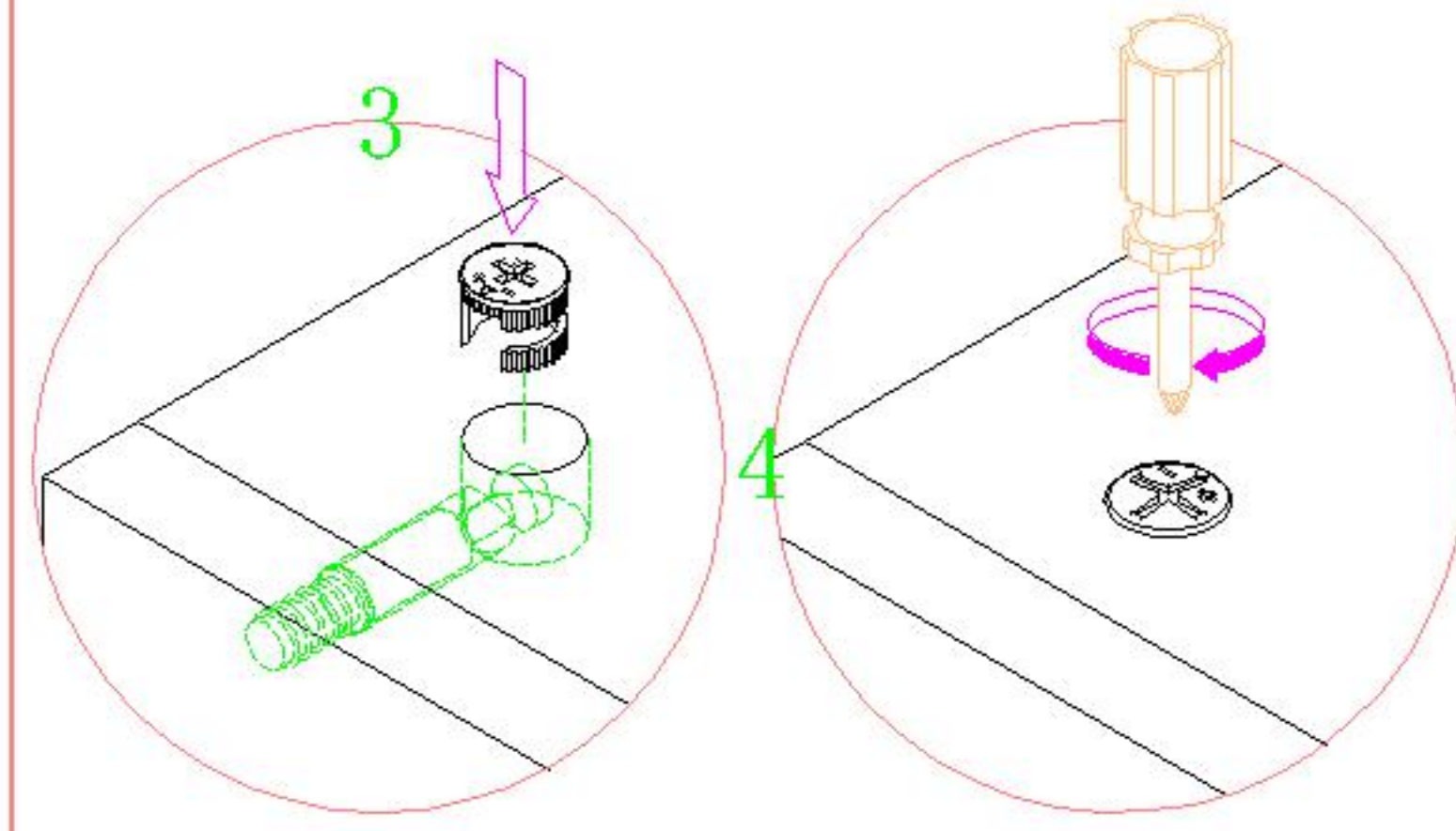
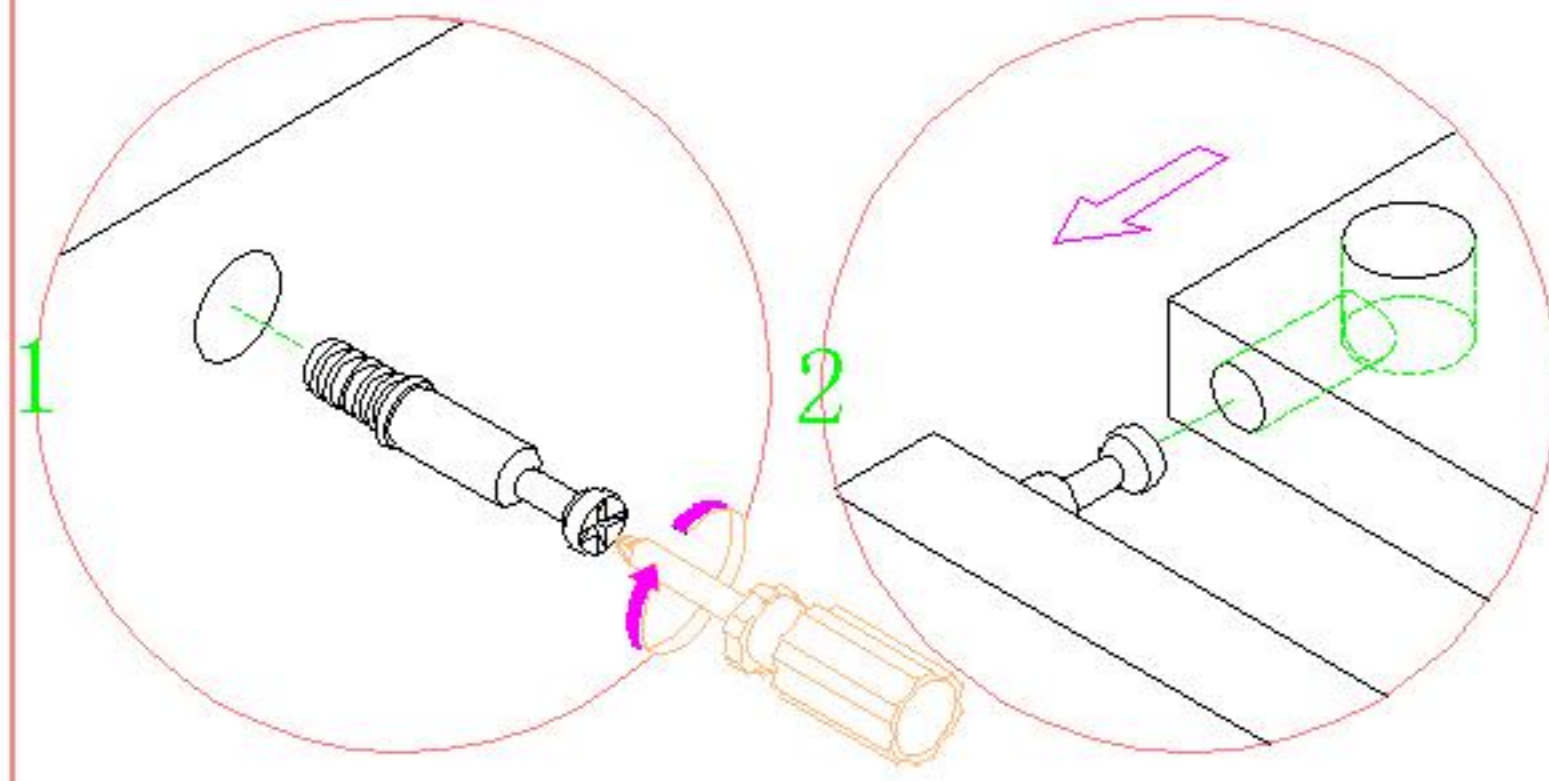

小二合一  
small two-in-one

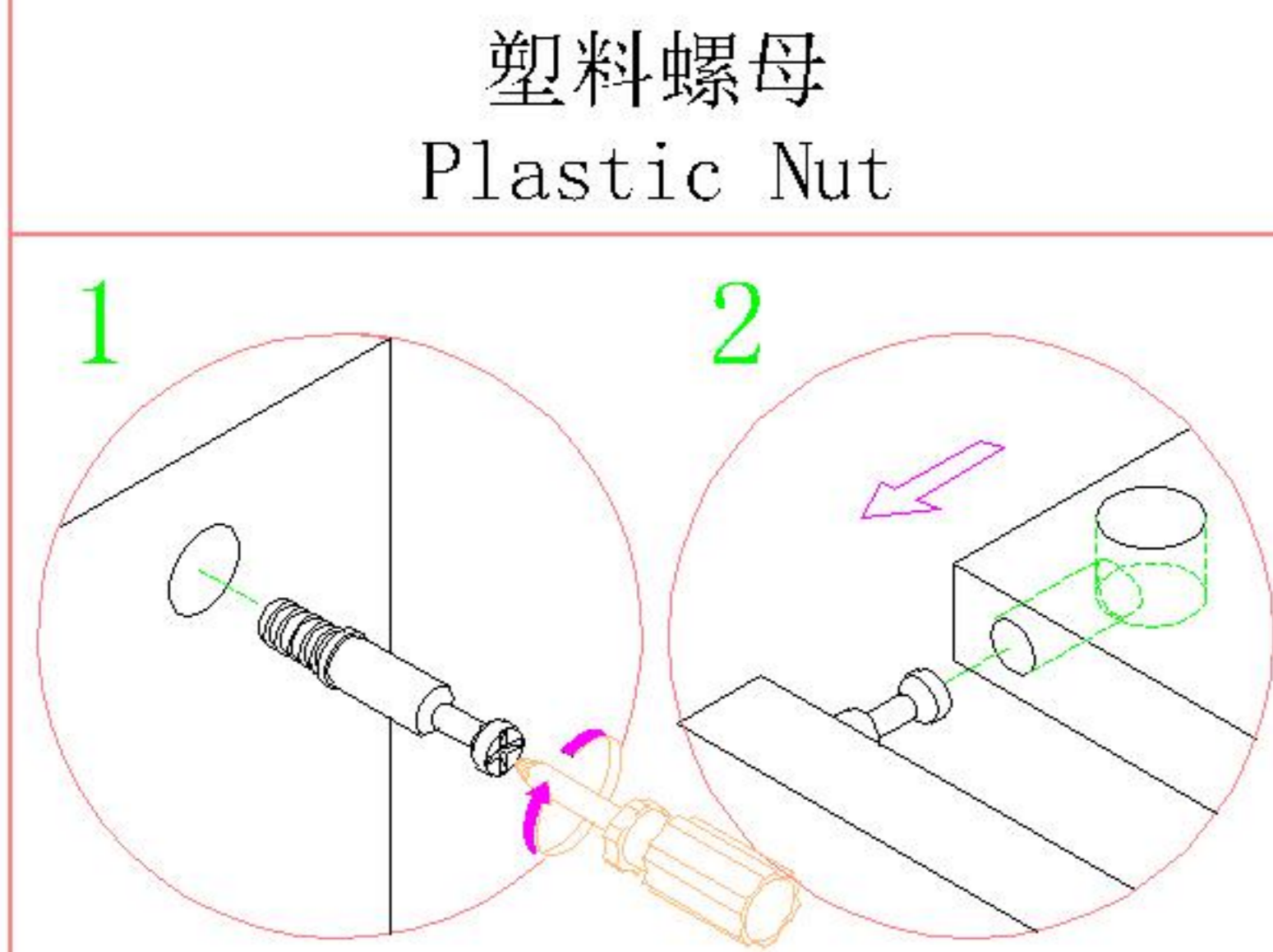
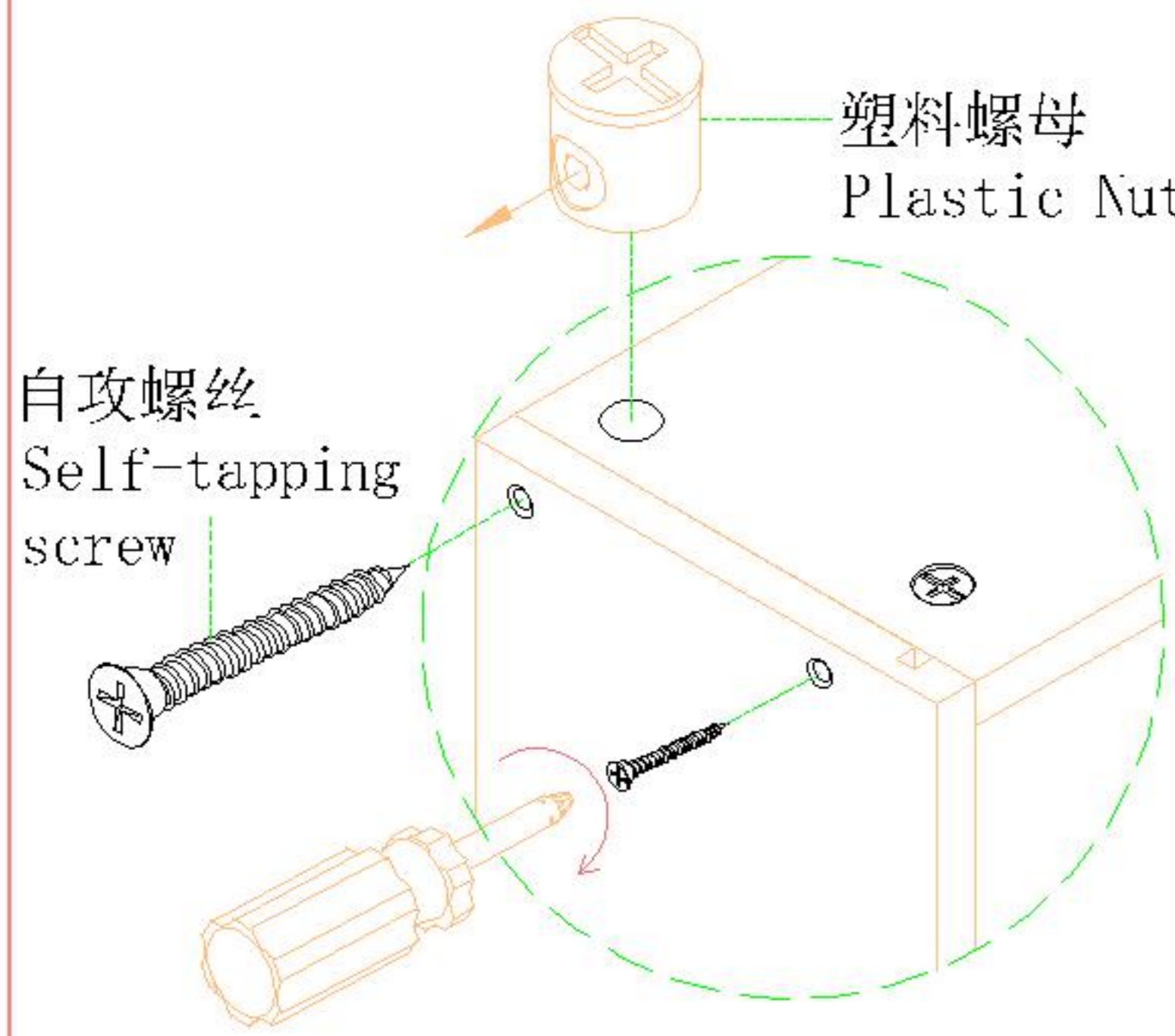

大二合一  
two-in-one

(K)\*8



(L)\*8

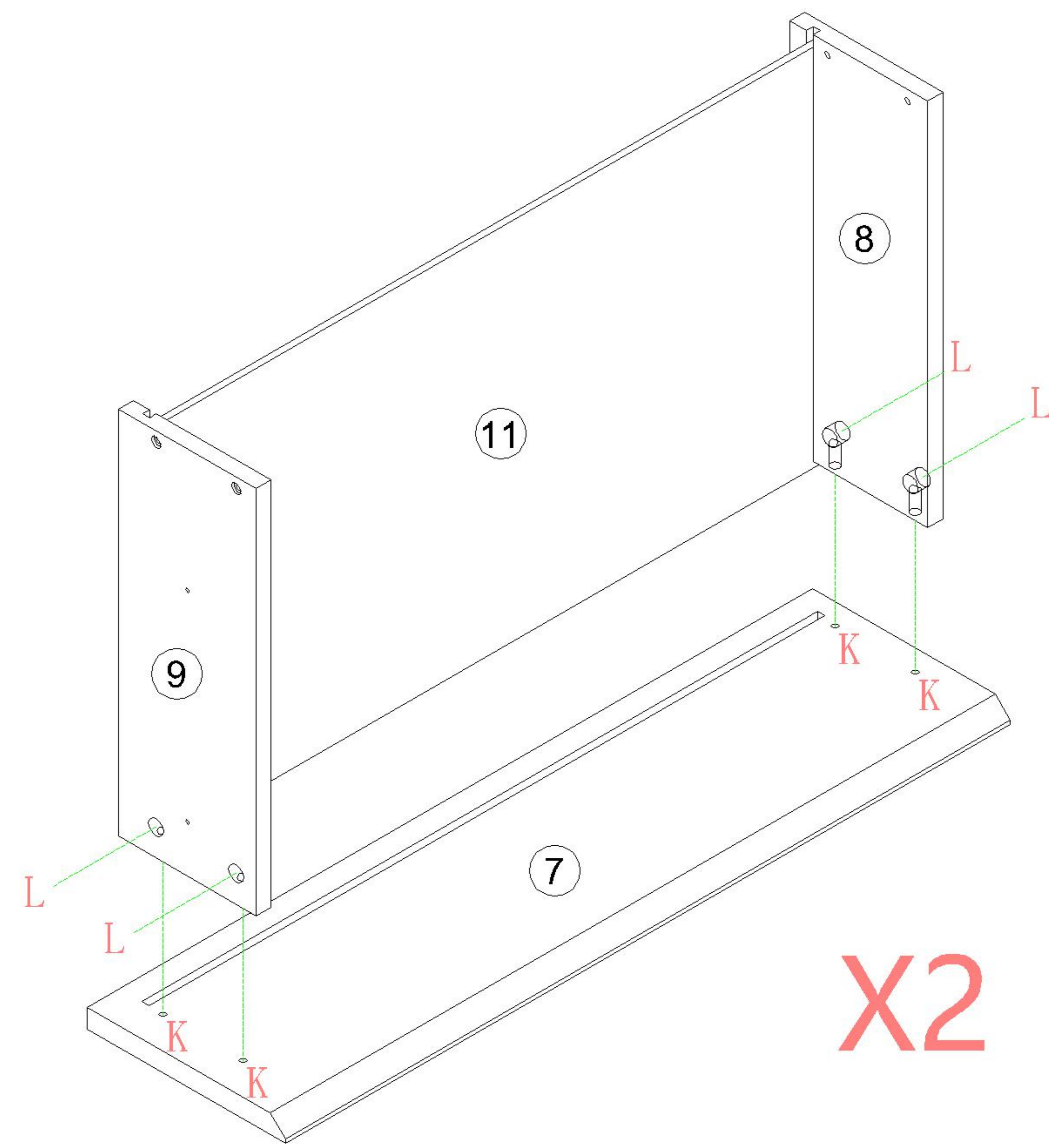

1

(M)\*8



(C)\*12



(N)\*8



(A)\*2

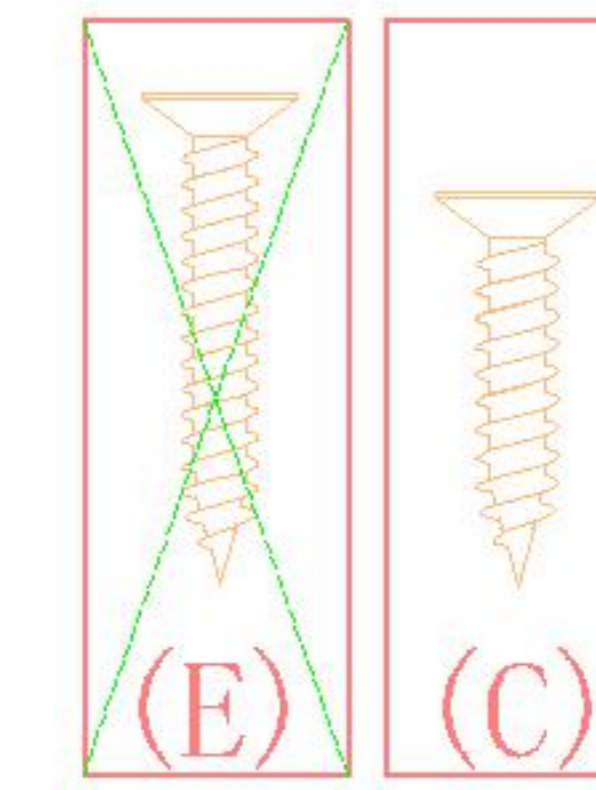

(A) 副轨  
Sub rail

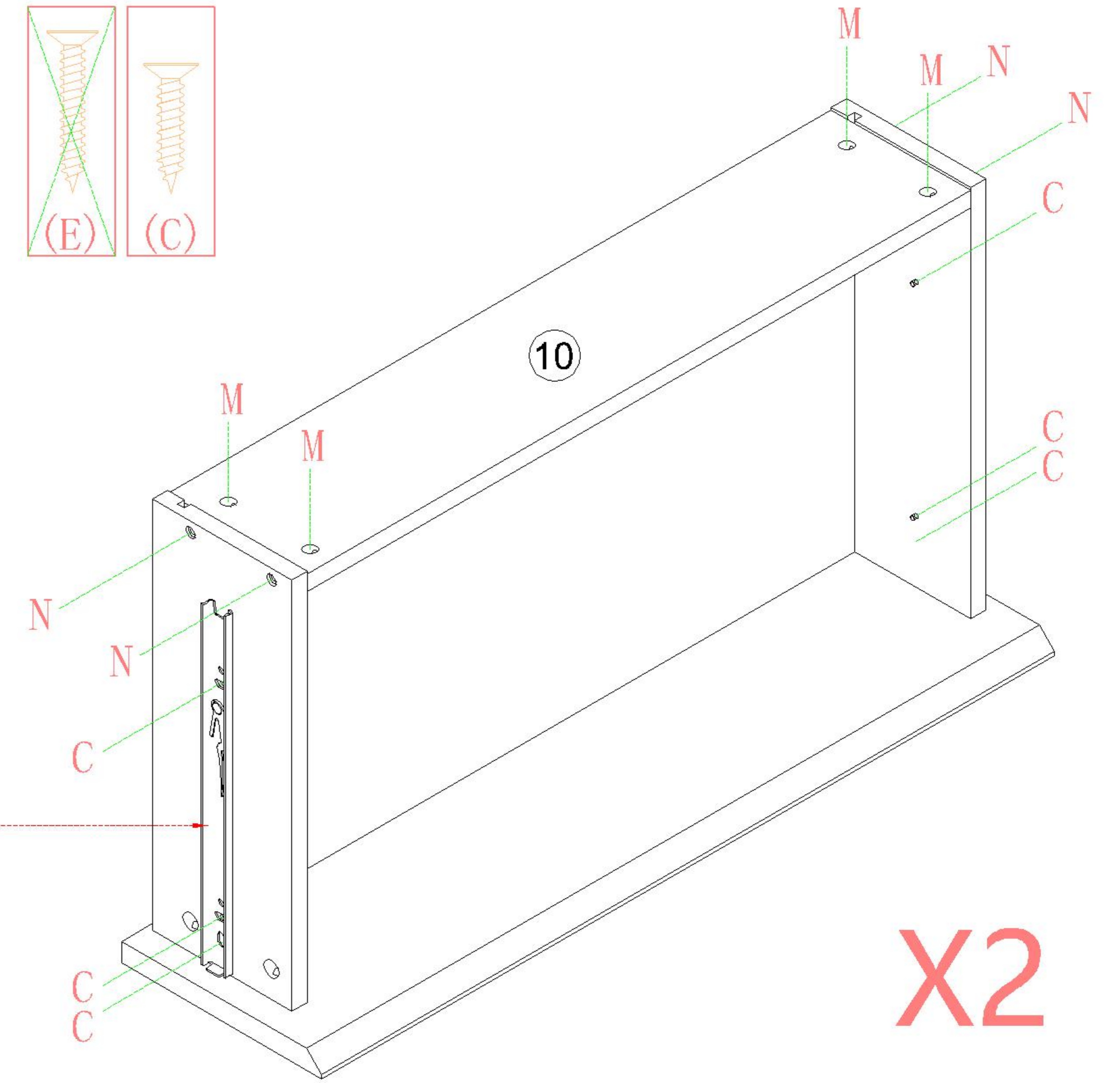

2

(K)\*4



(L)\*4

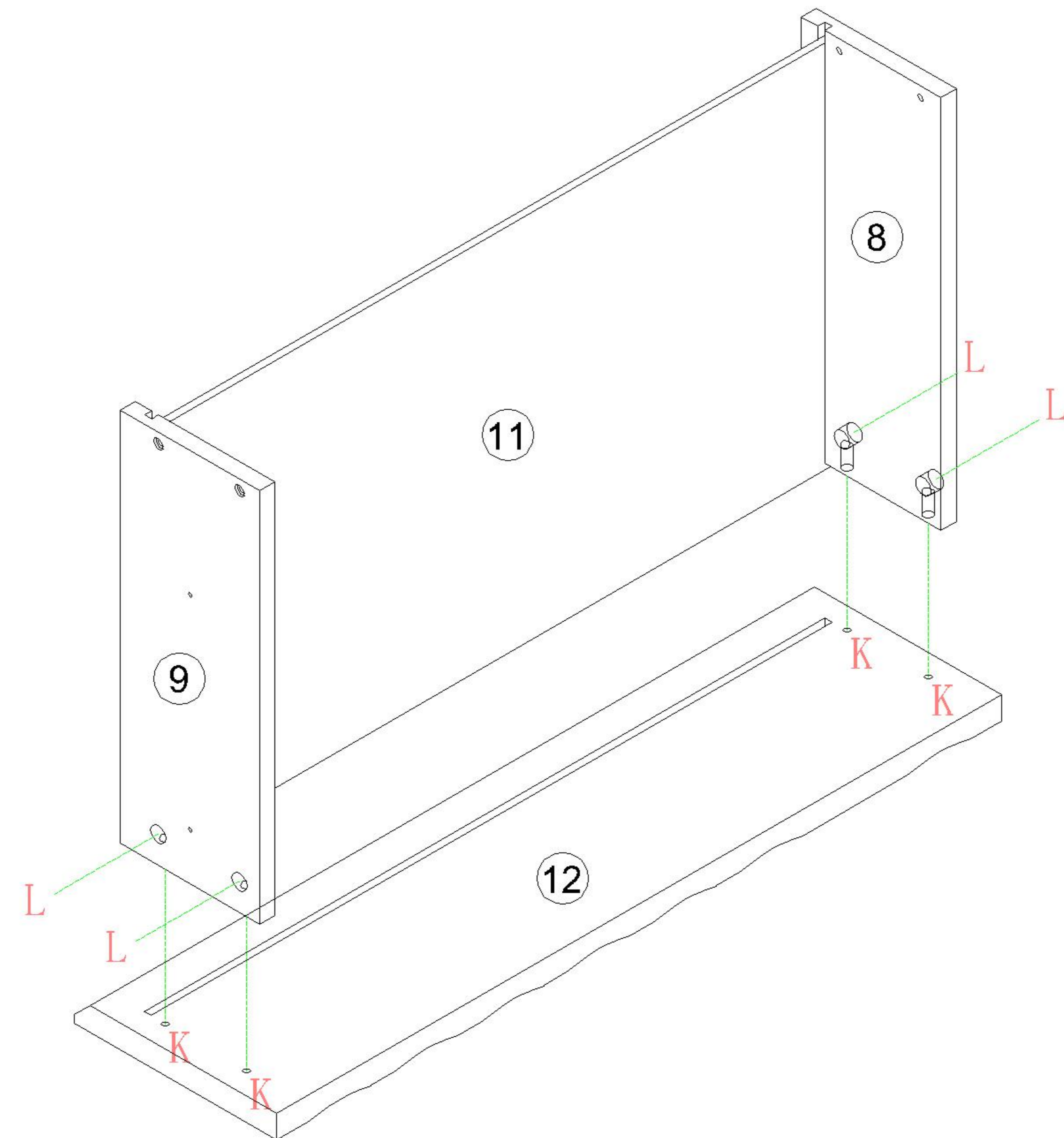

3

(M)\*4

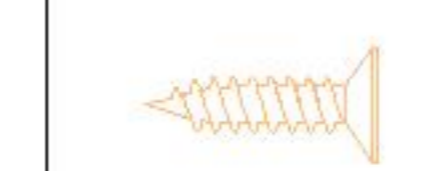

(C)\*6



(N)\*4



(A)\*1

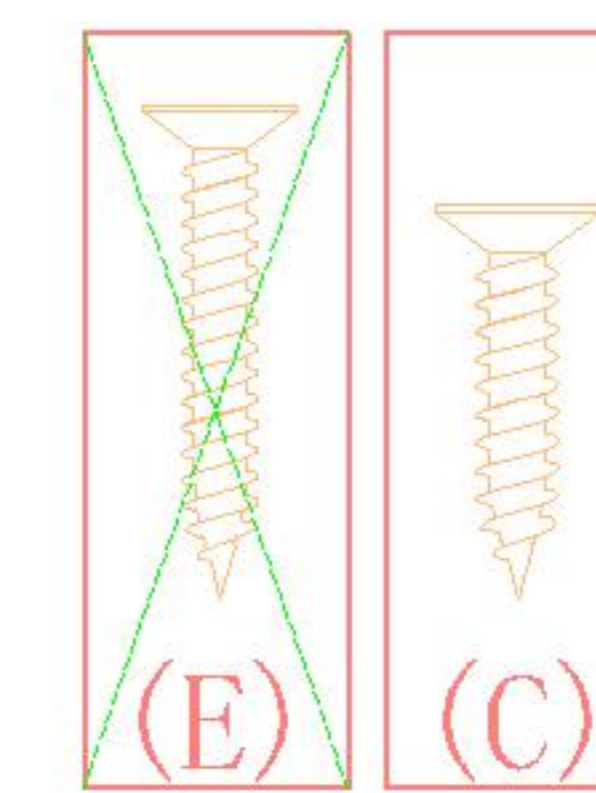

(A) 副轨  
Sub rail

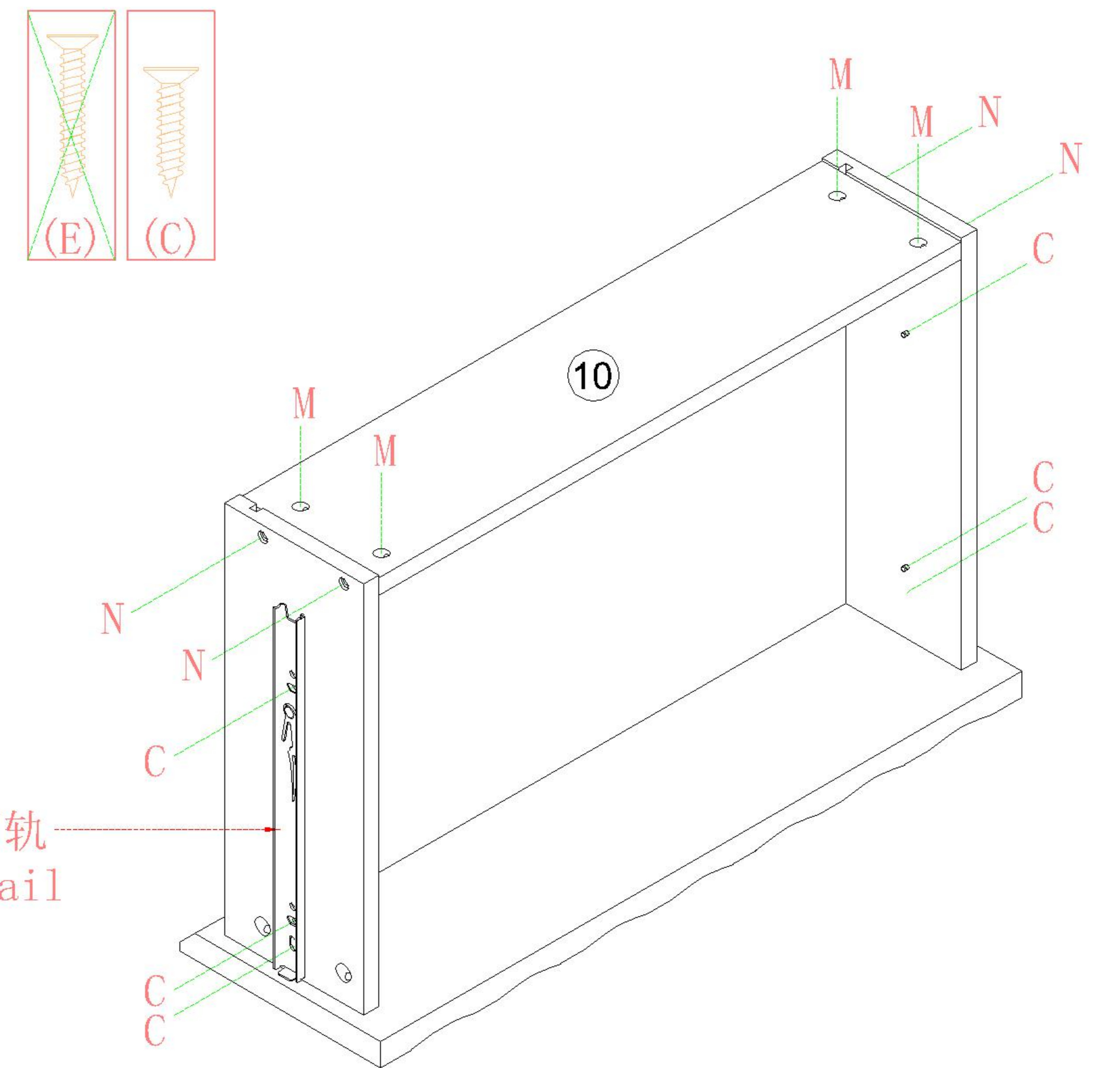

4

PM1E-A

安装方法/  
Installation method

阀门开关(下压为开)  
Valve switch  
(press down to open)

1

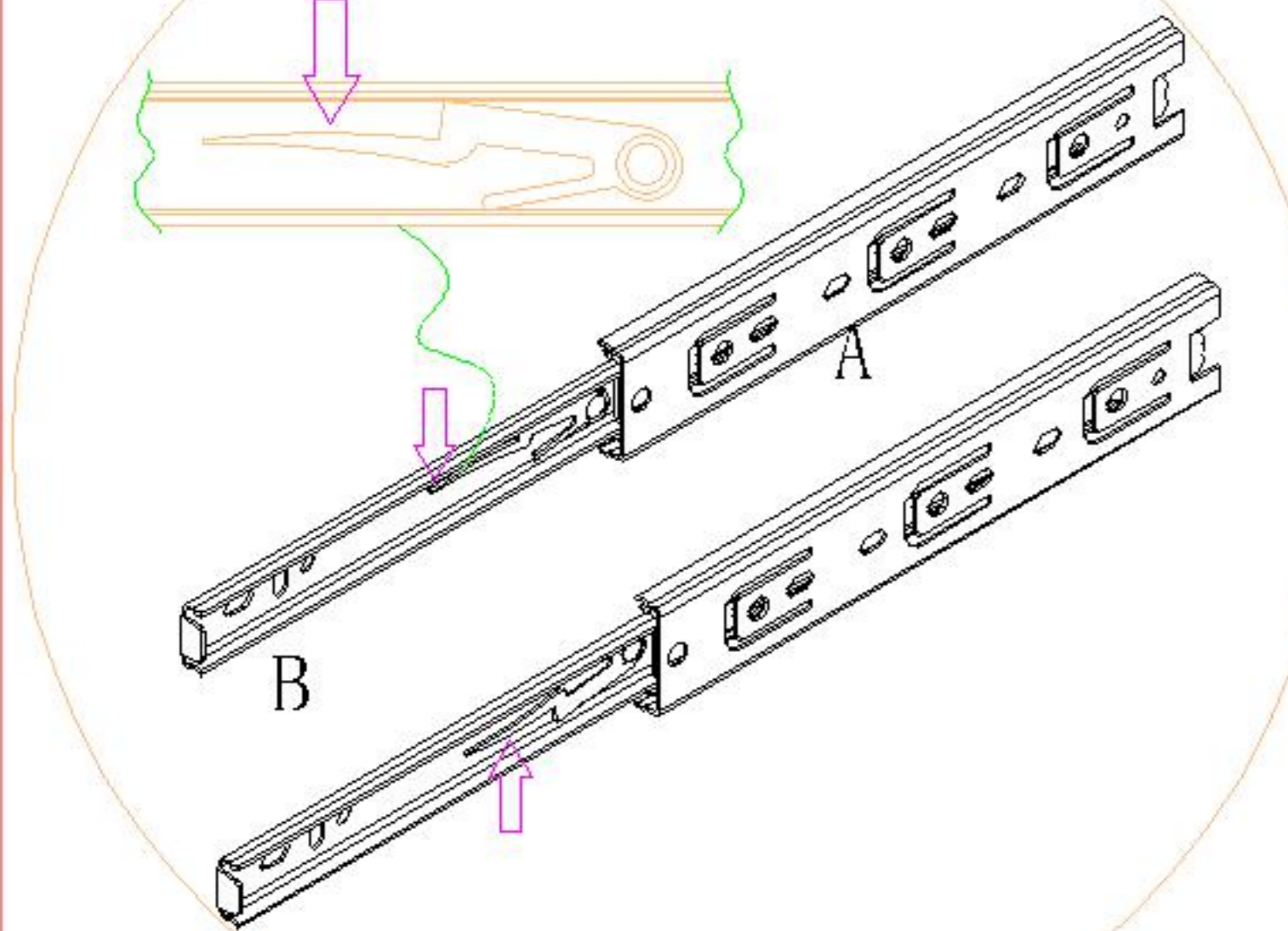

注: 先将A与B拆下来  
Note: remove a and B first

侧板  
side board

2

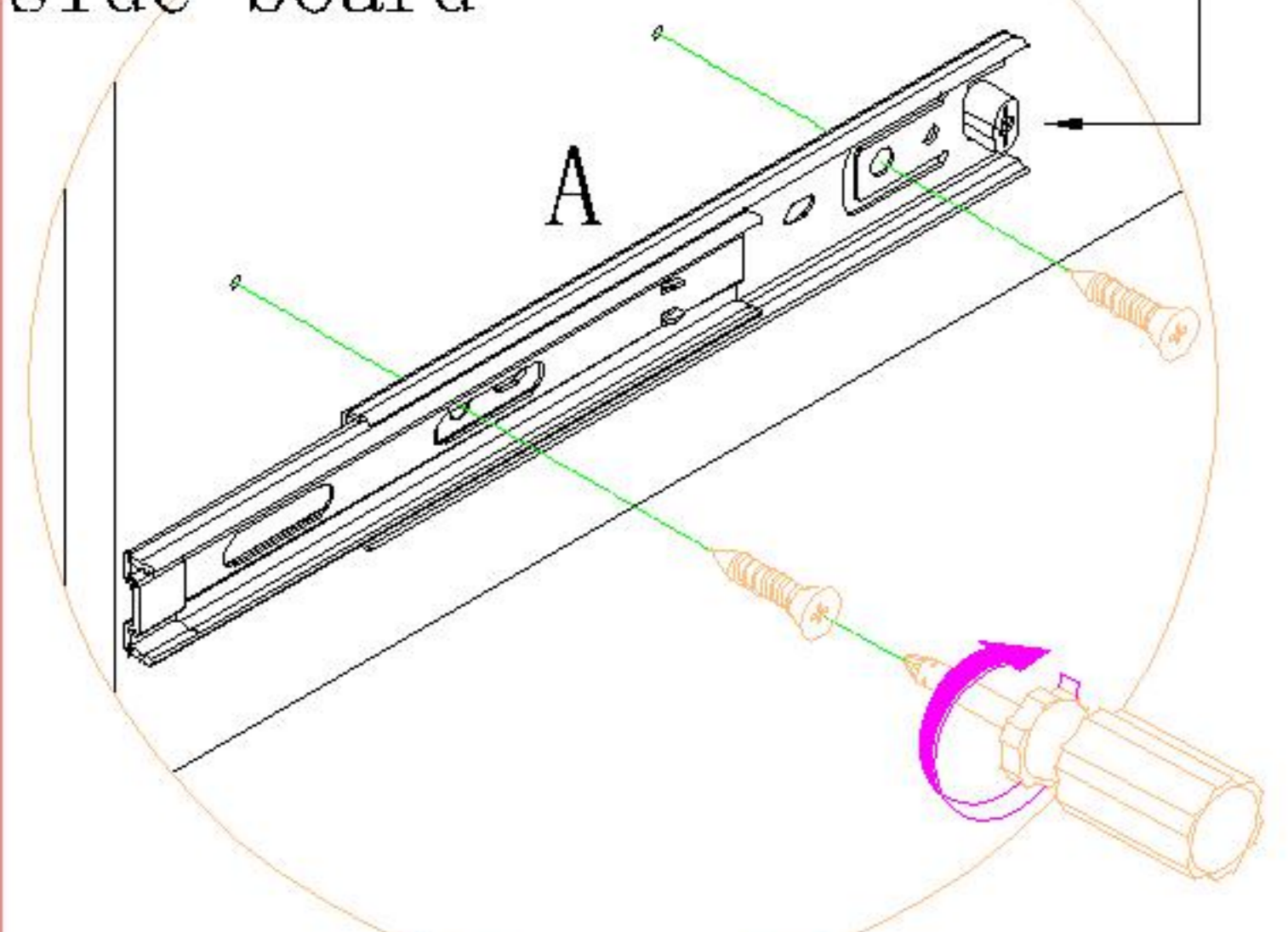

抽屉侧板  
sideboard  
of the drawer

3

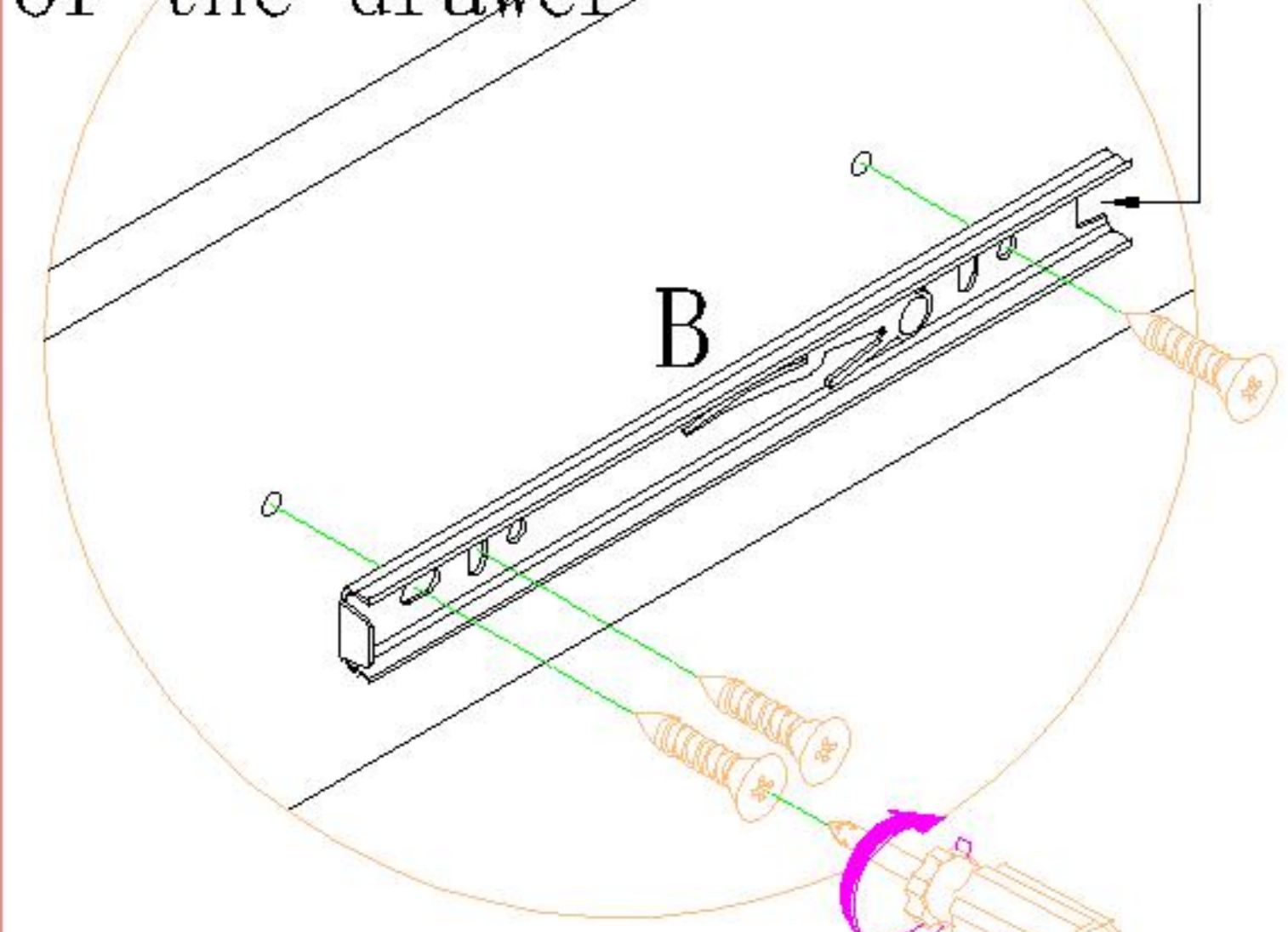

注: 将B对准A后推进去  
Note: align B with a  
and push it in

5

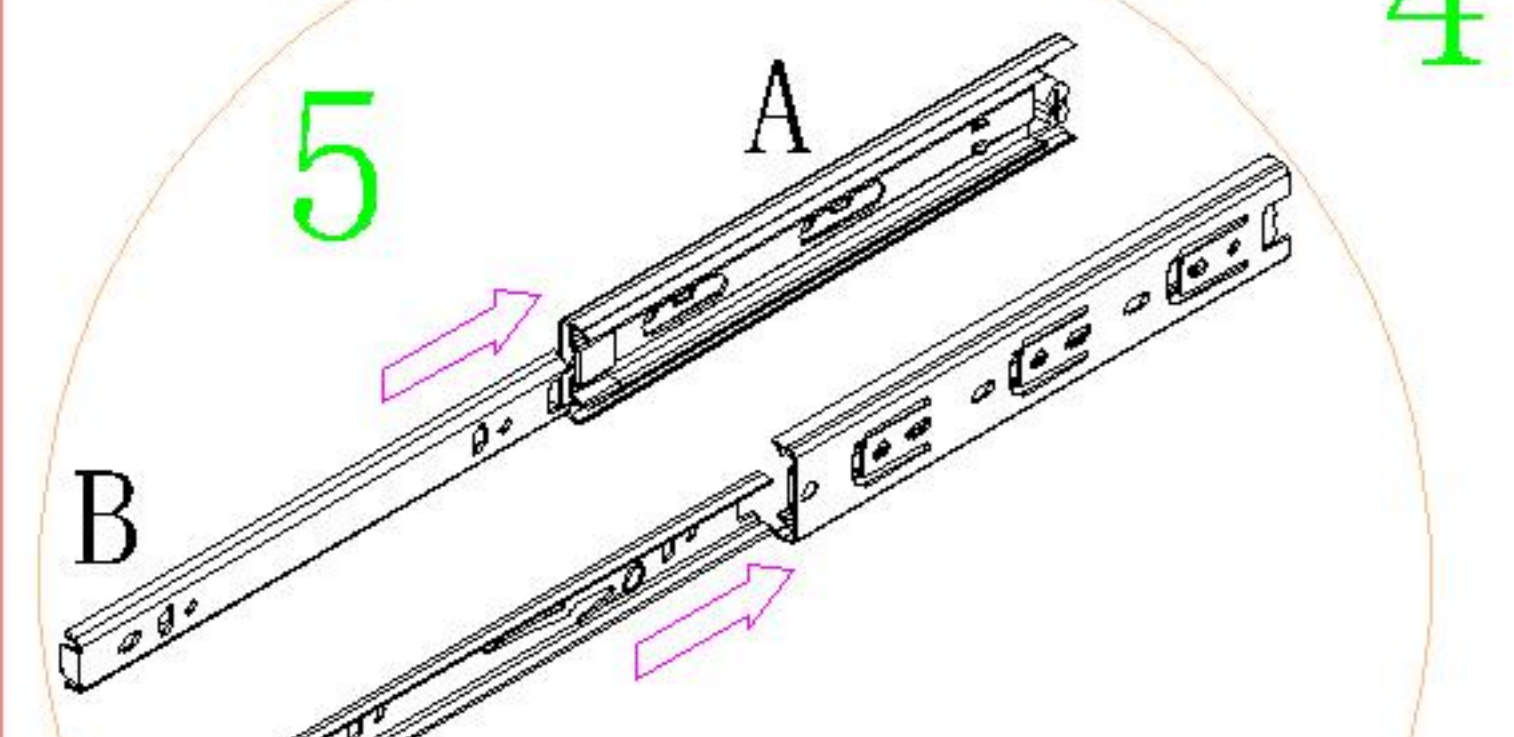

三节滚珠导轨  
three-section ball rail

(F)\*8



(G)\*8



(B)\*1



(F)\*4



(G)\*4



(H)\*4



(H)\*4

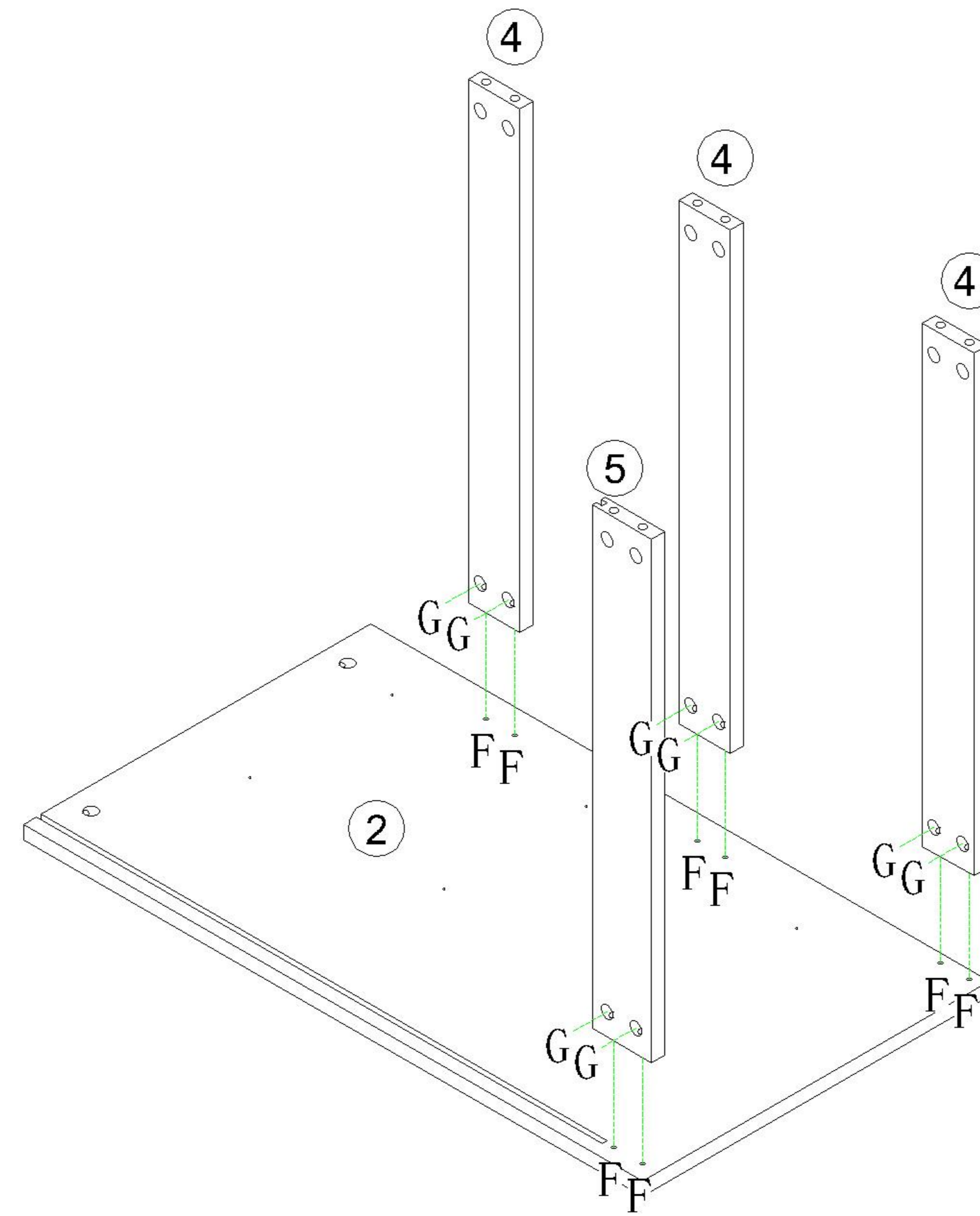

5

(F)\*8



(G)\*8



(J)\*8

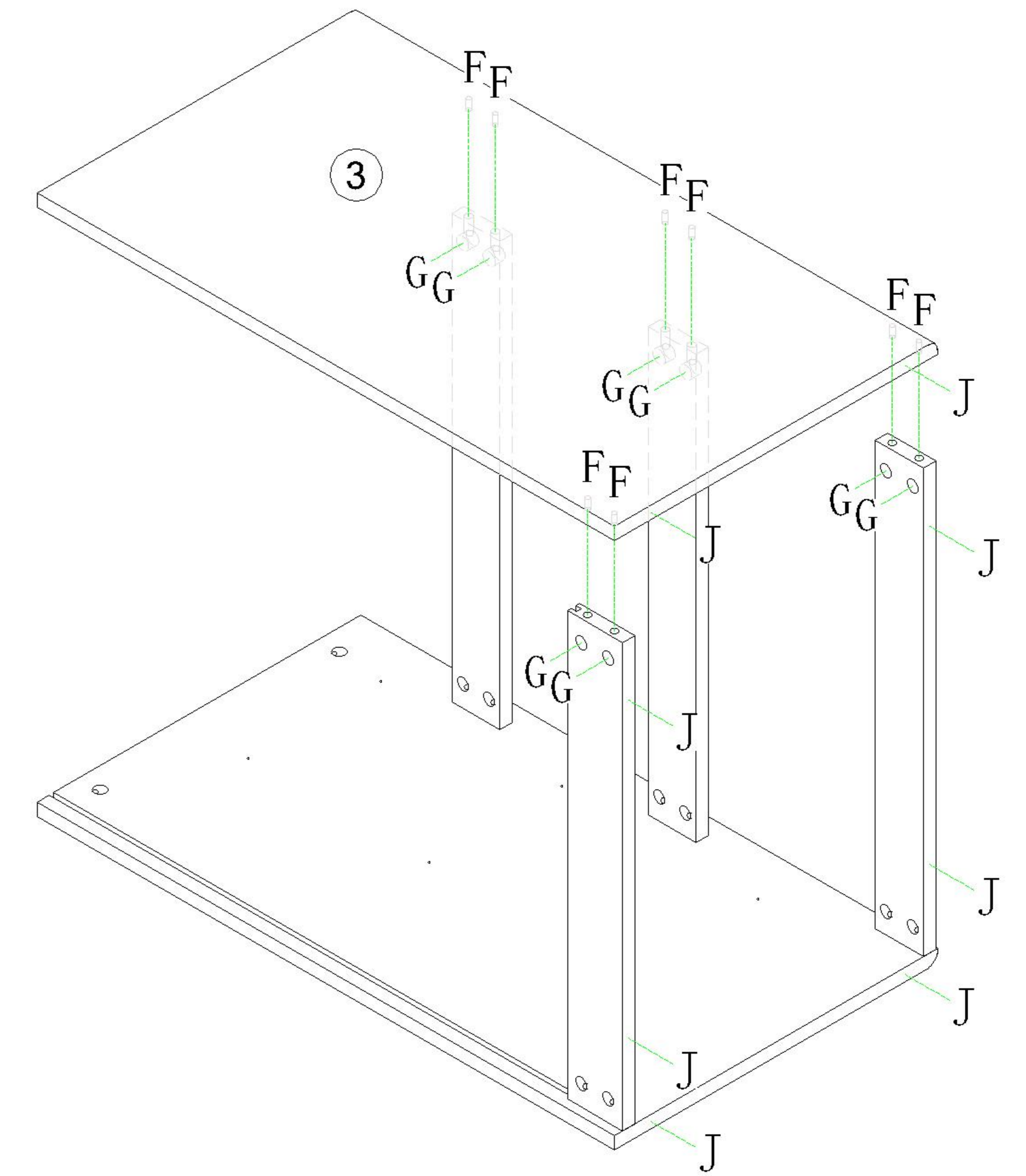

6

7

(A)\*3

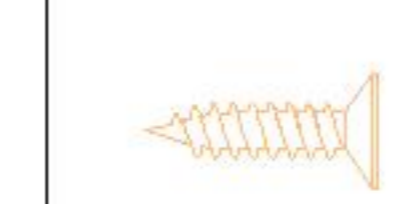

(C)\*18

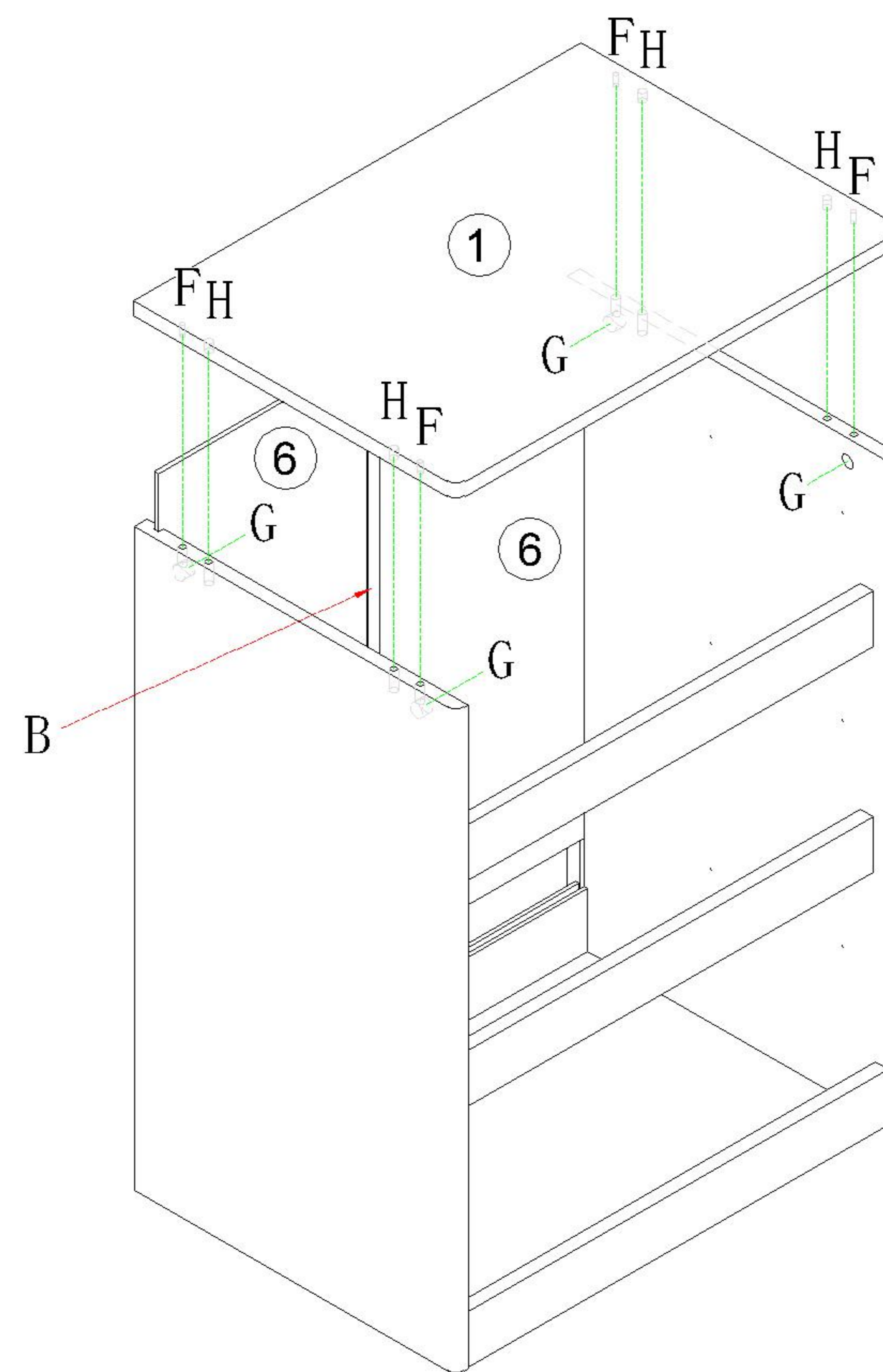

8

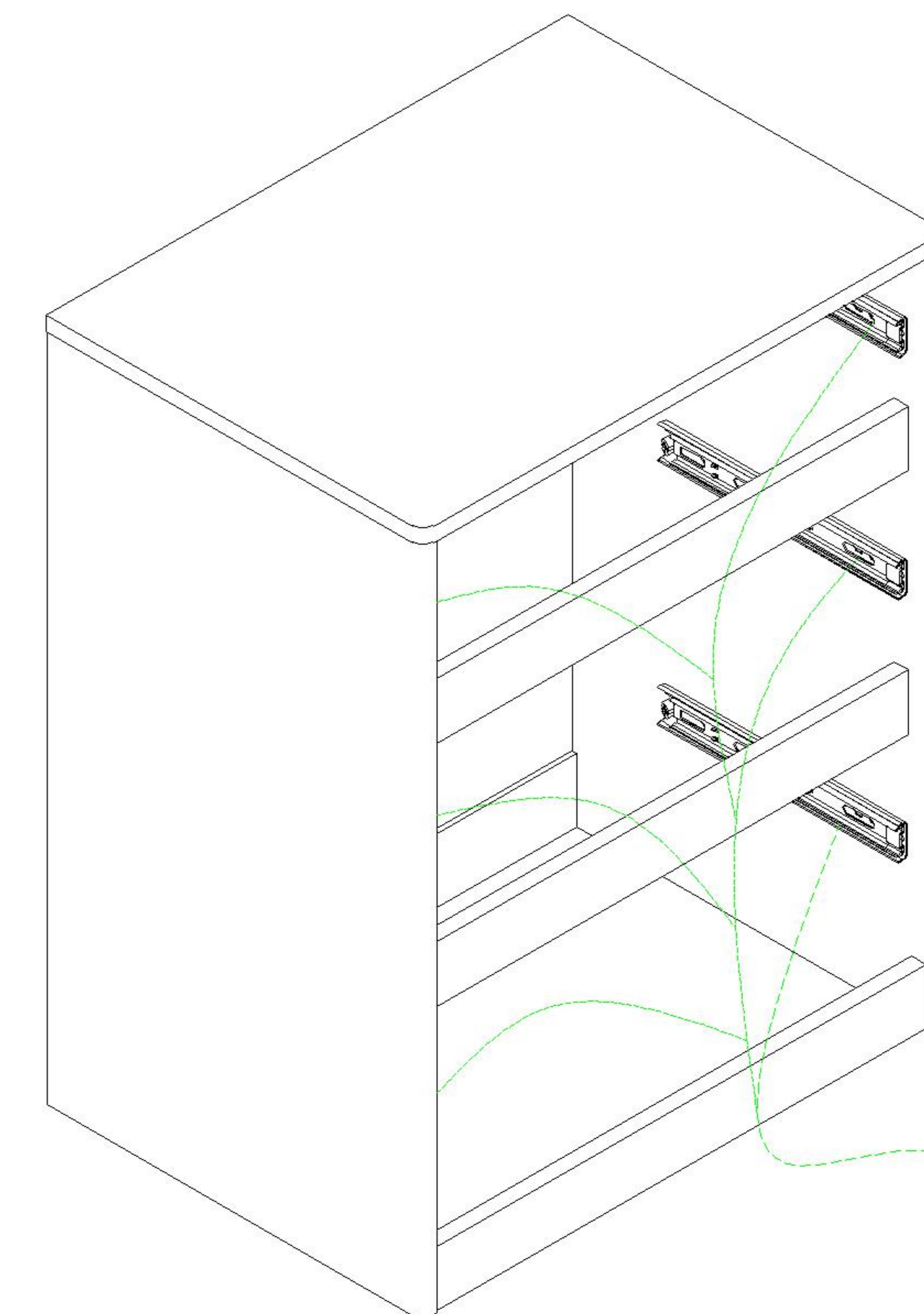

A 主轨  
Main rail

## 安装示意图/Assembly Instruction

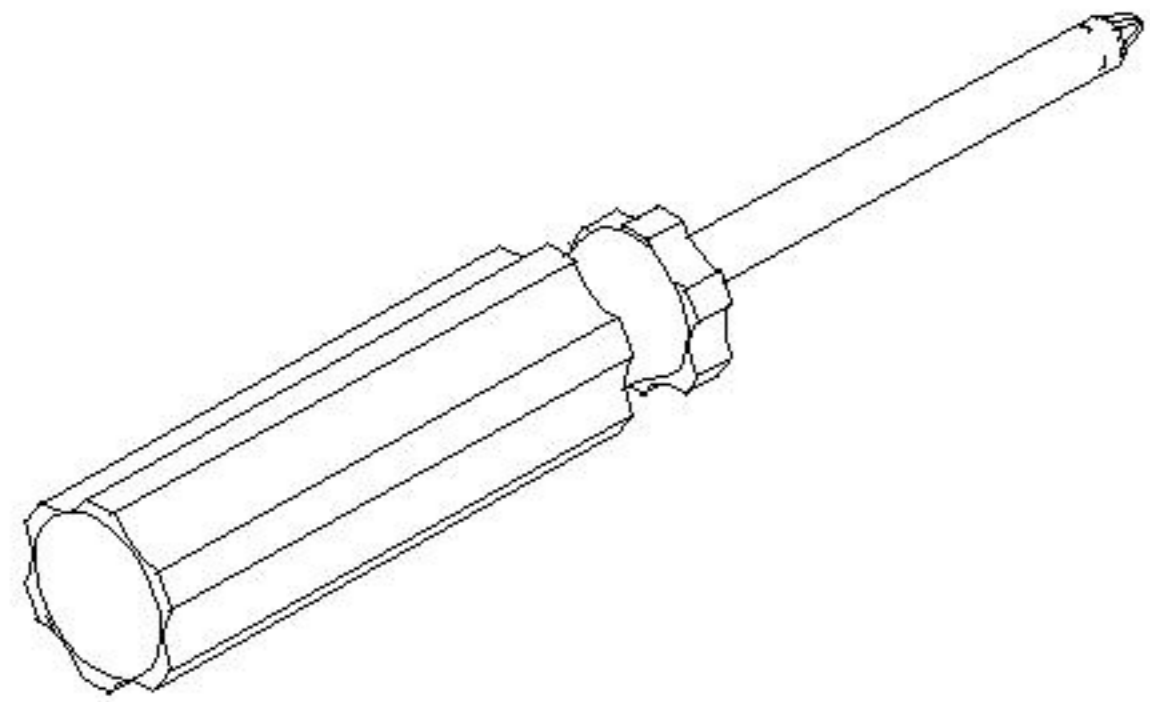
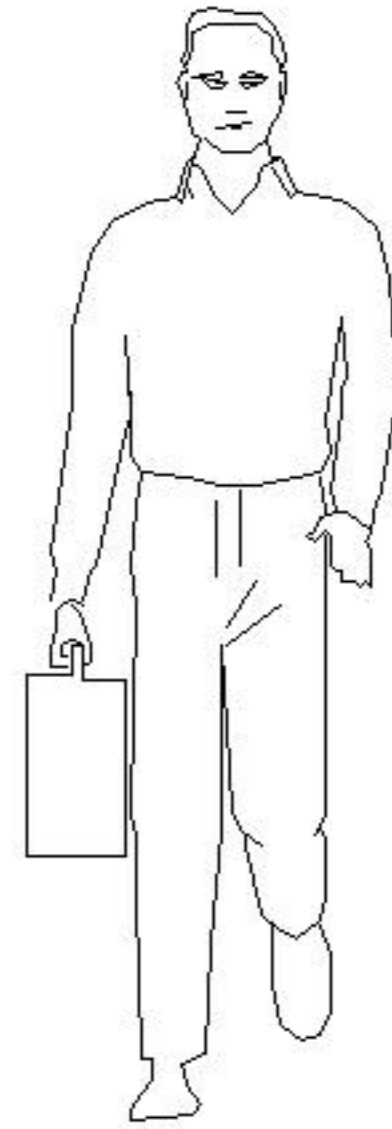
产品名称 Model NO.	Anti-fall device
产品规格 Specification	-
安装工具 Tool	安装人数 Installer
	

  
(I)\* 1  
家具防倒器-白色  
Anti-fall device  
white

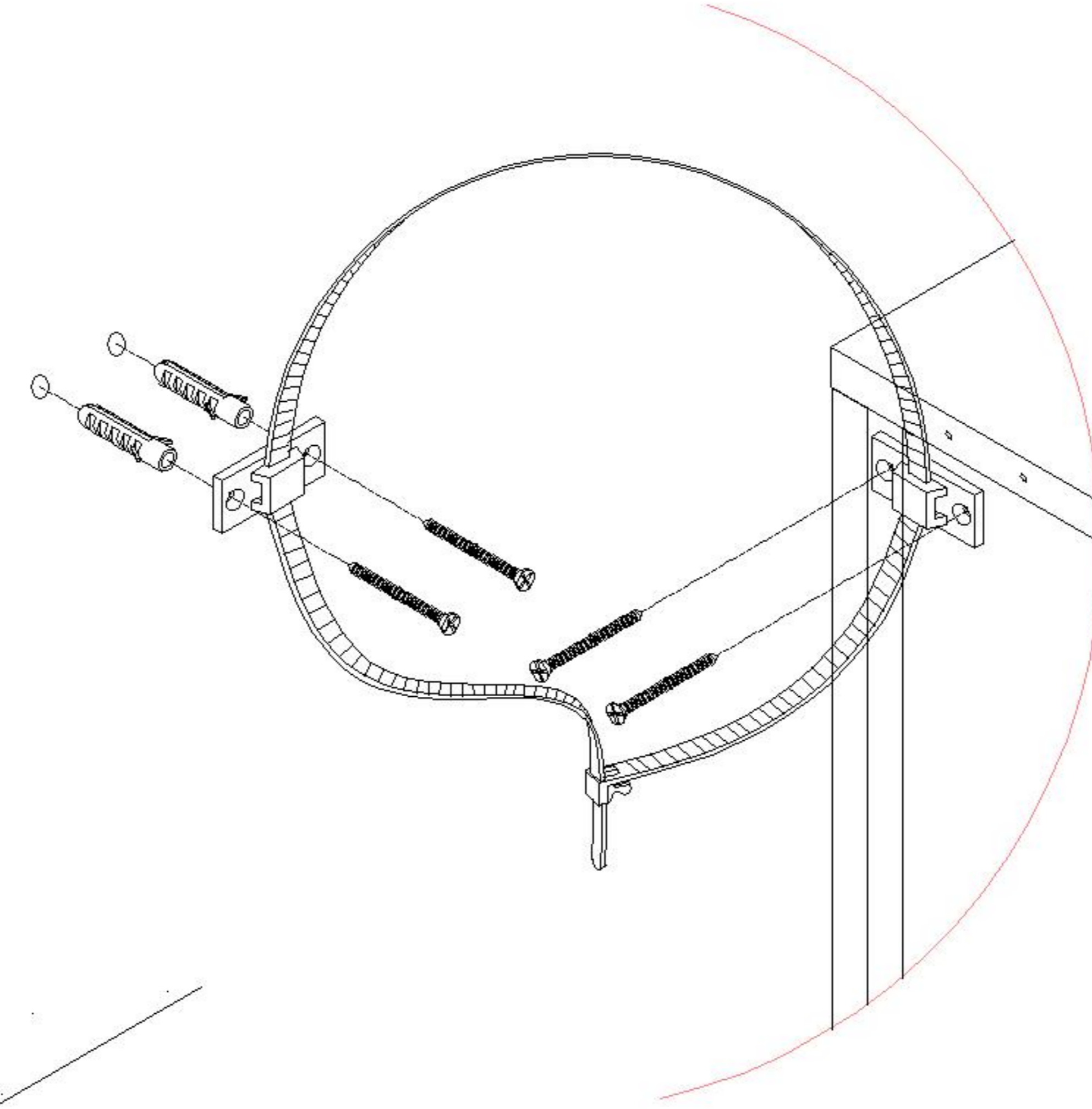

I处放大图  
Enlarged view at I

实体墙  
Solid wall

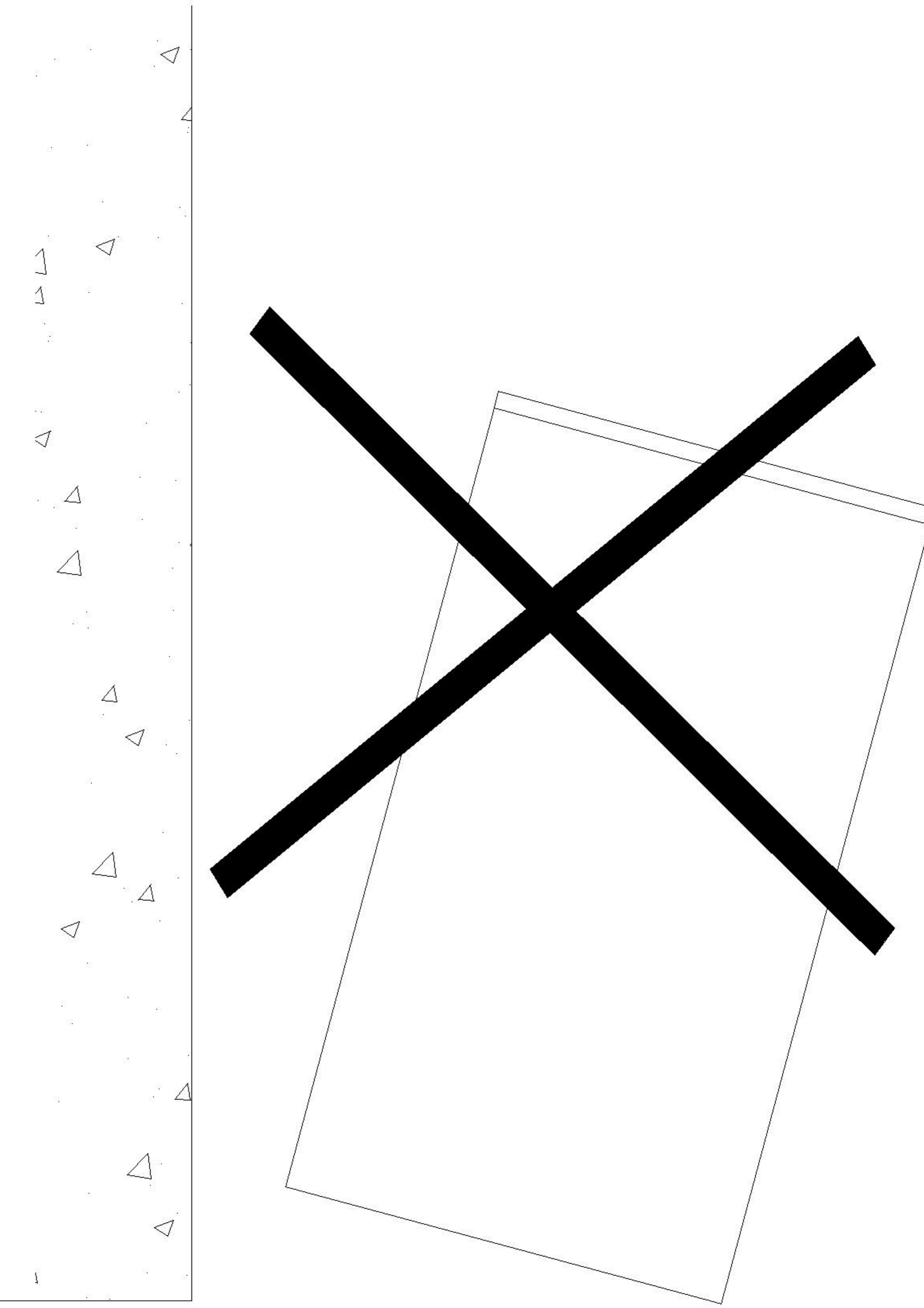
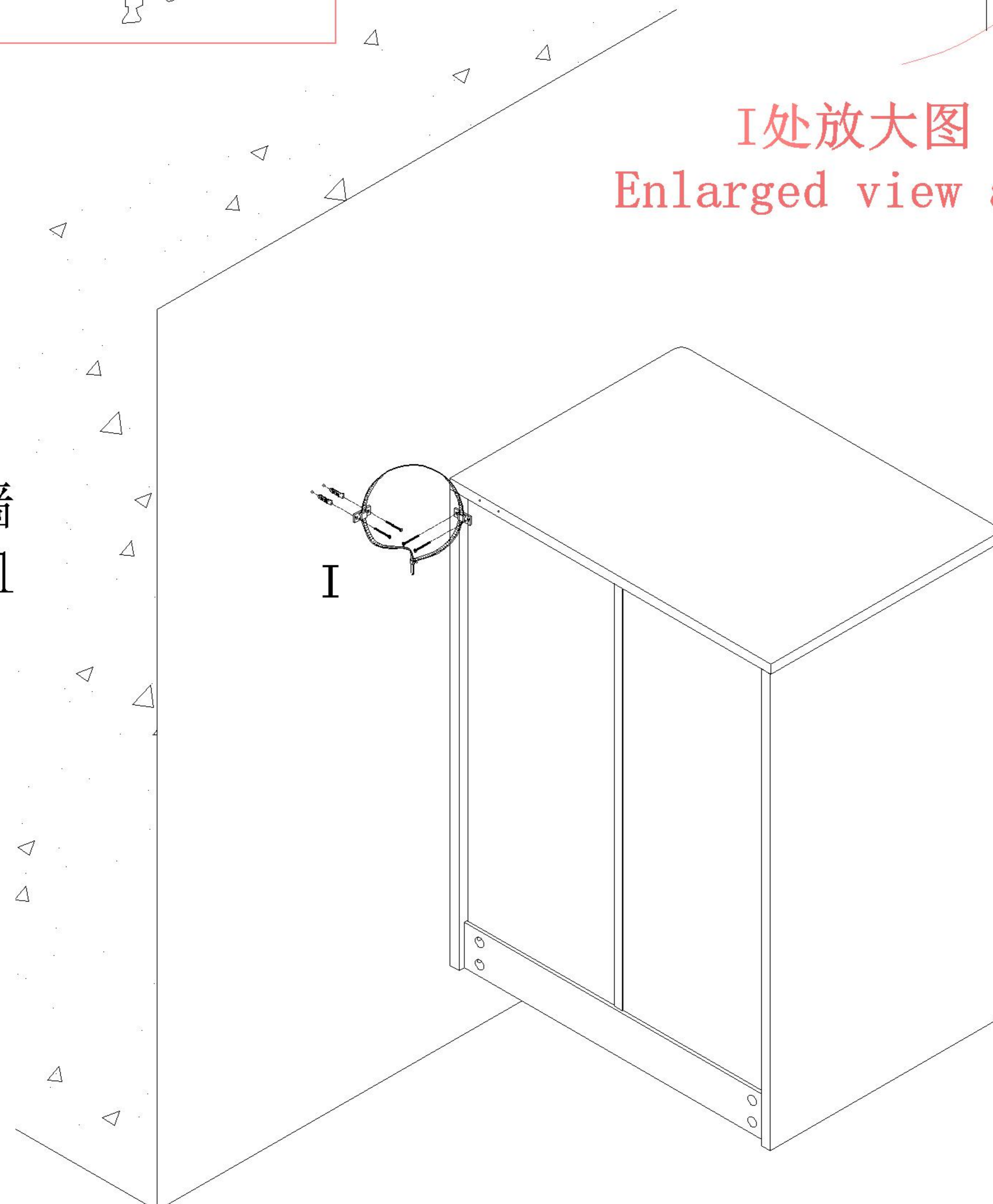

### 安装示意图/Assembly Instruction

产品名称 Model NO.	PM1C-A / PM2C-A
产品规格 Specification	(1190-1600)*391*753mm (1720-2180)*391*753mm
安装工具 Tool	安装人数 Installer

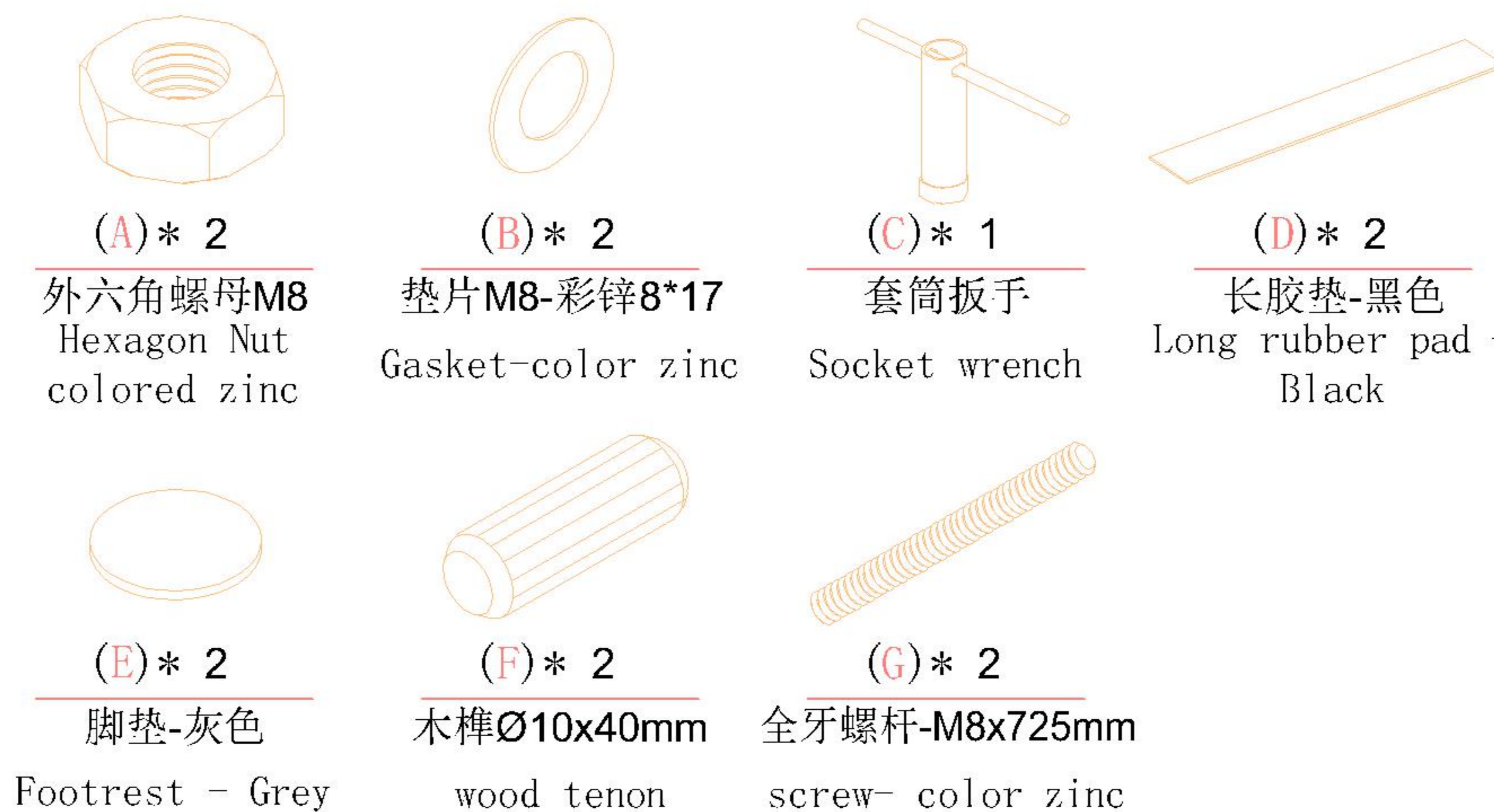
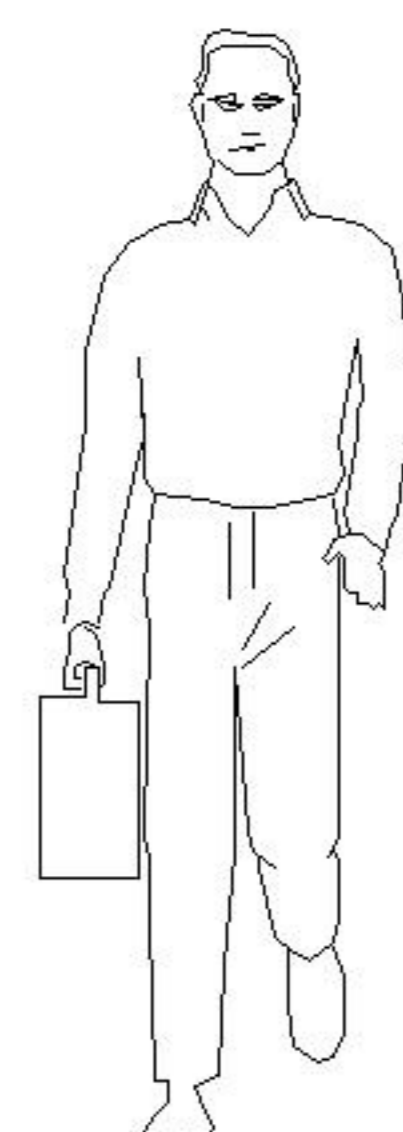
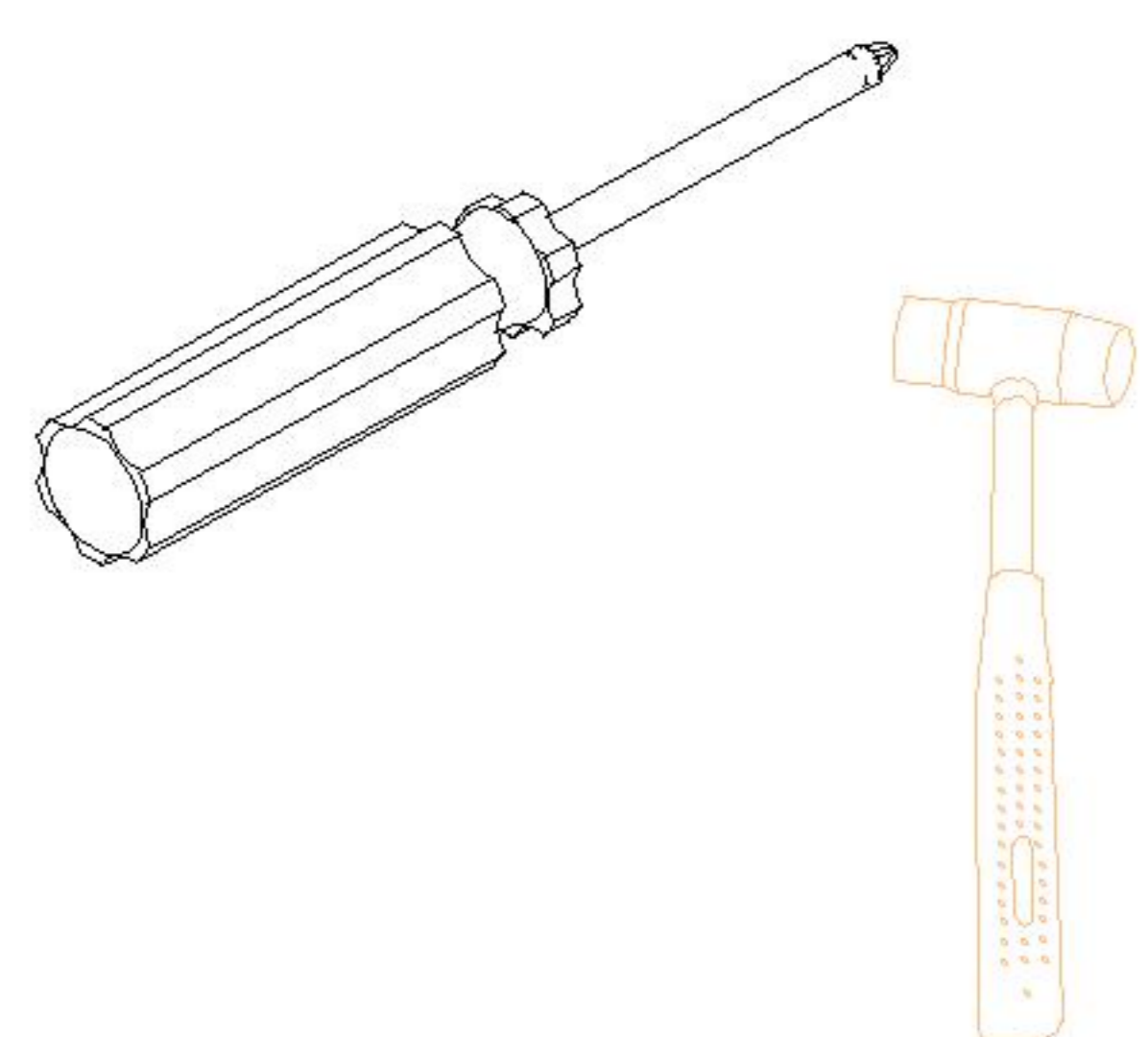

编号NO.	名称Name	规格 (mm) Specification	数量QTY	材质Material
①	面板 Top panel	1190*391*36	1	人造板WBP
②	侧板 Side board	714*389*36	1	人造板WBP
③	三斗柜 Three Bucket cabinet	574*391*714	1	人造板WBP
④	六斗柜 Six Bucket cabinet	1149*391*714	1	人造板WBP

请适当调整妆台长度，使妆台稳固不易倾倒。座位净空最窄不少于525mm，最长不长于1000mm。

Please adjust the length of the dresser appropriately to make it stable and not easy to topple. The narrowest seat clearance shall not be less than 525mm and the longest shall not be longer than 1000mm.

PM1C-A  
(1190-1600)\*391\*753mm

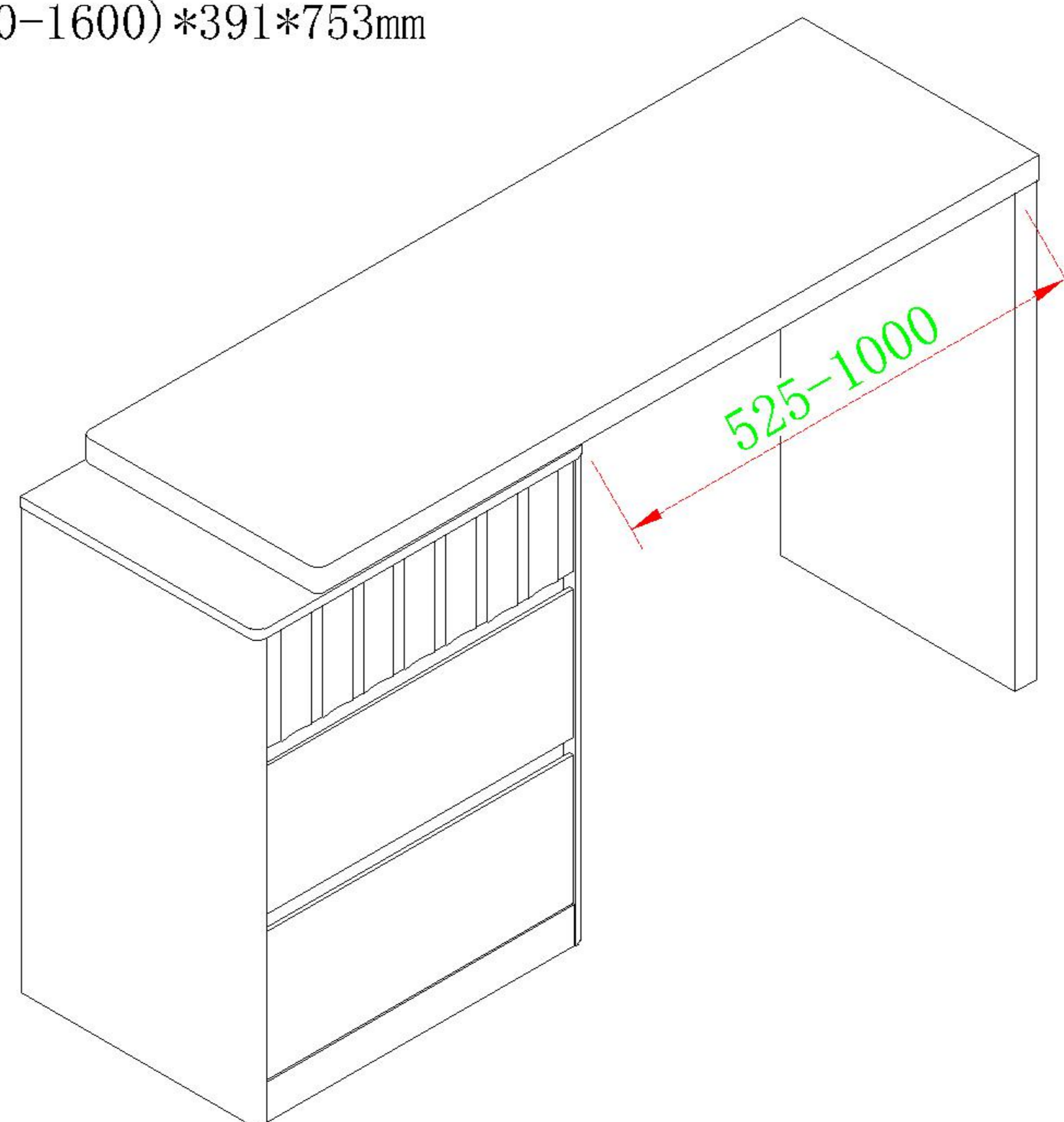

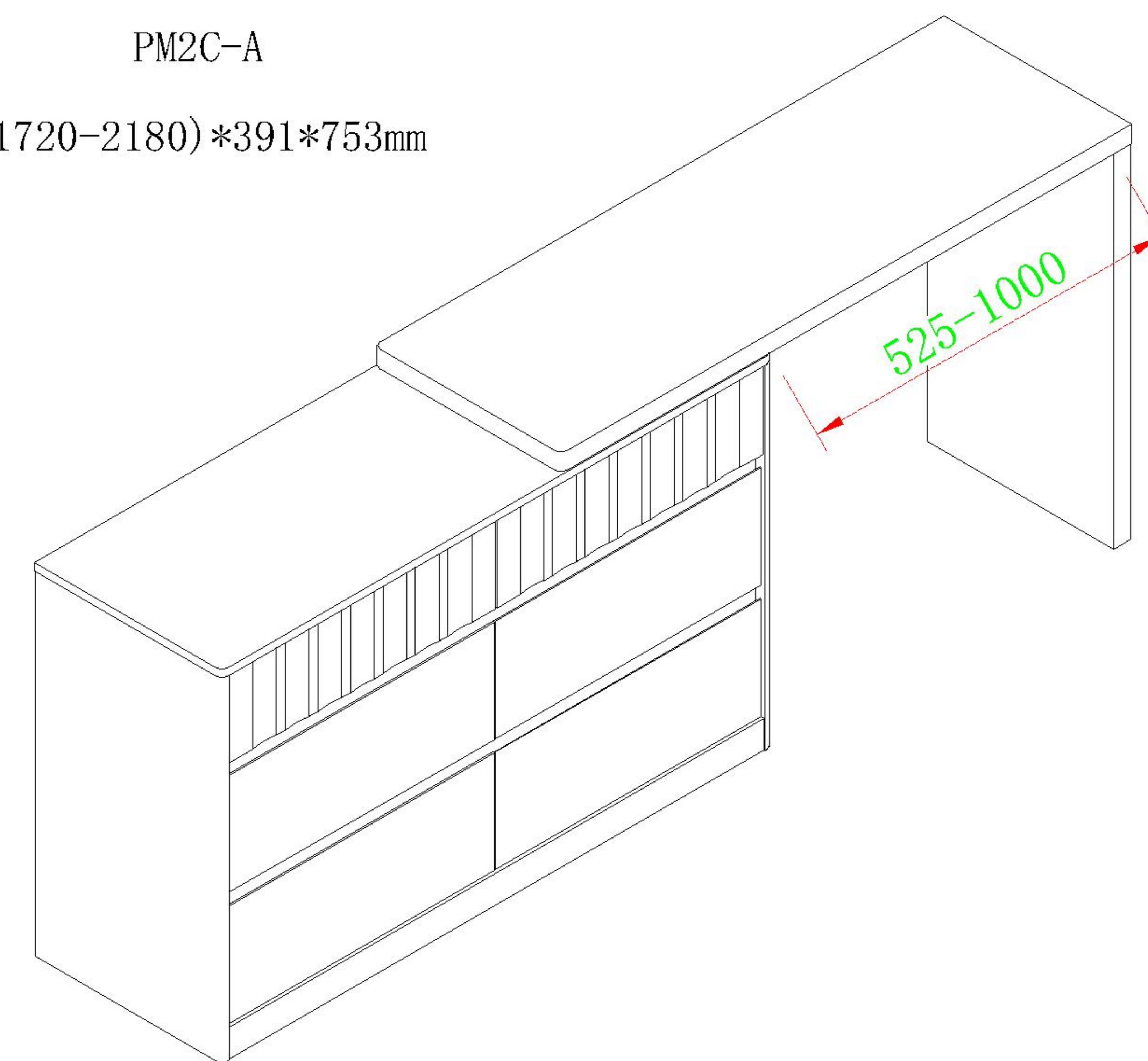

PM2C-A  
(1720-2180)\*391\*753mm





PM1C-A / PM2C-A

安装方法/  
Installation method

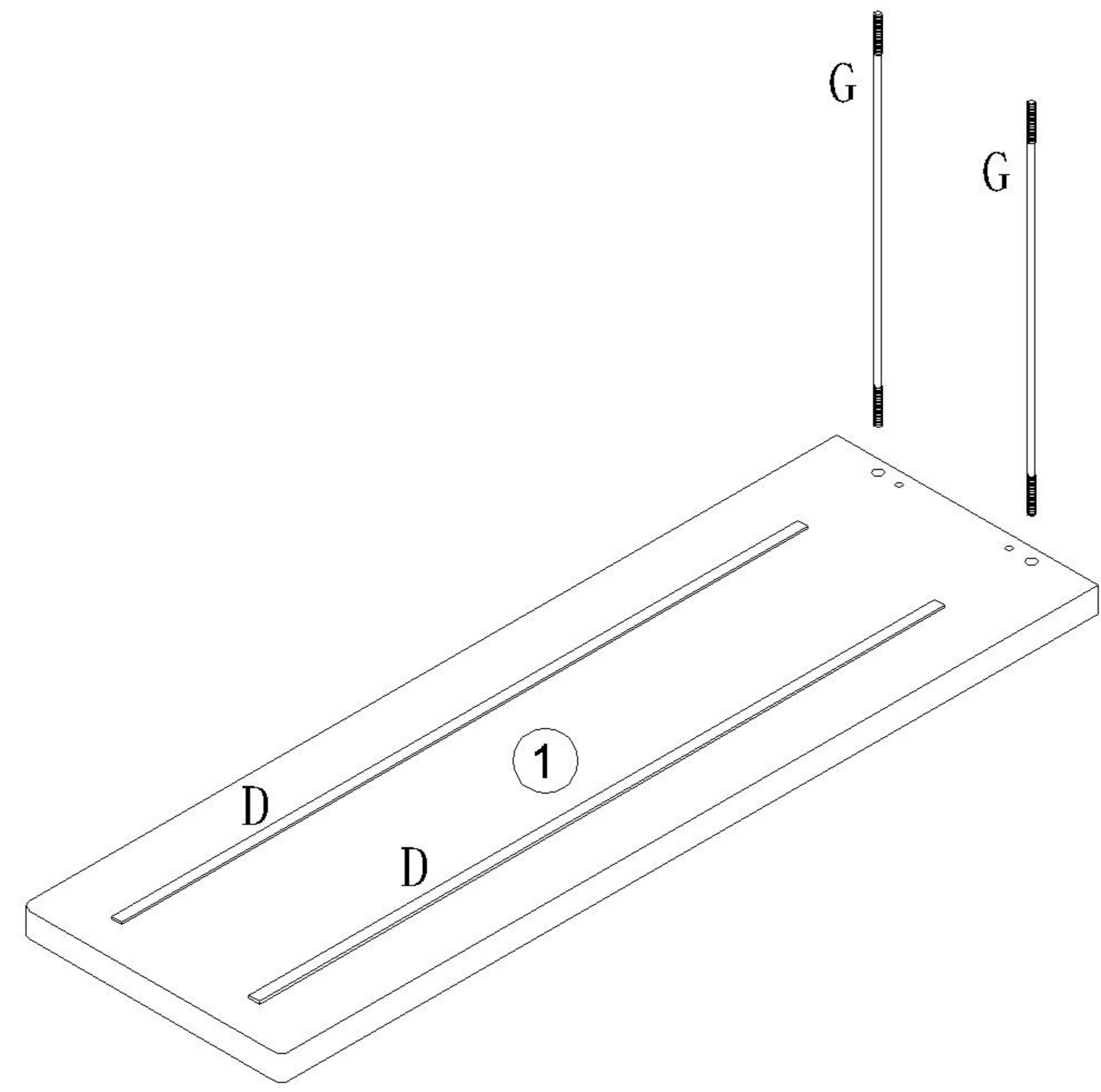
-  (D)\*2
-  (G)\*2



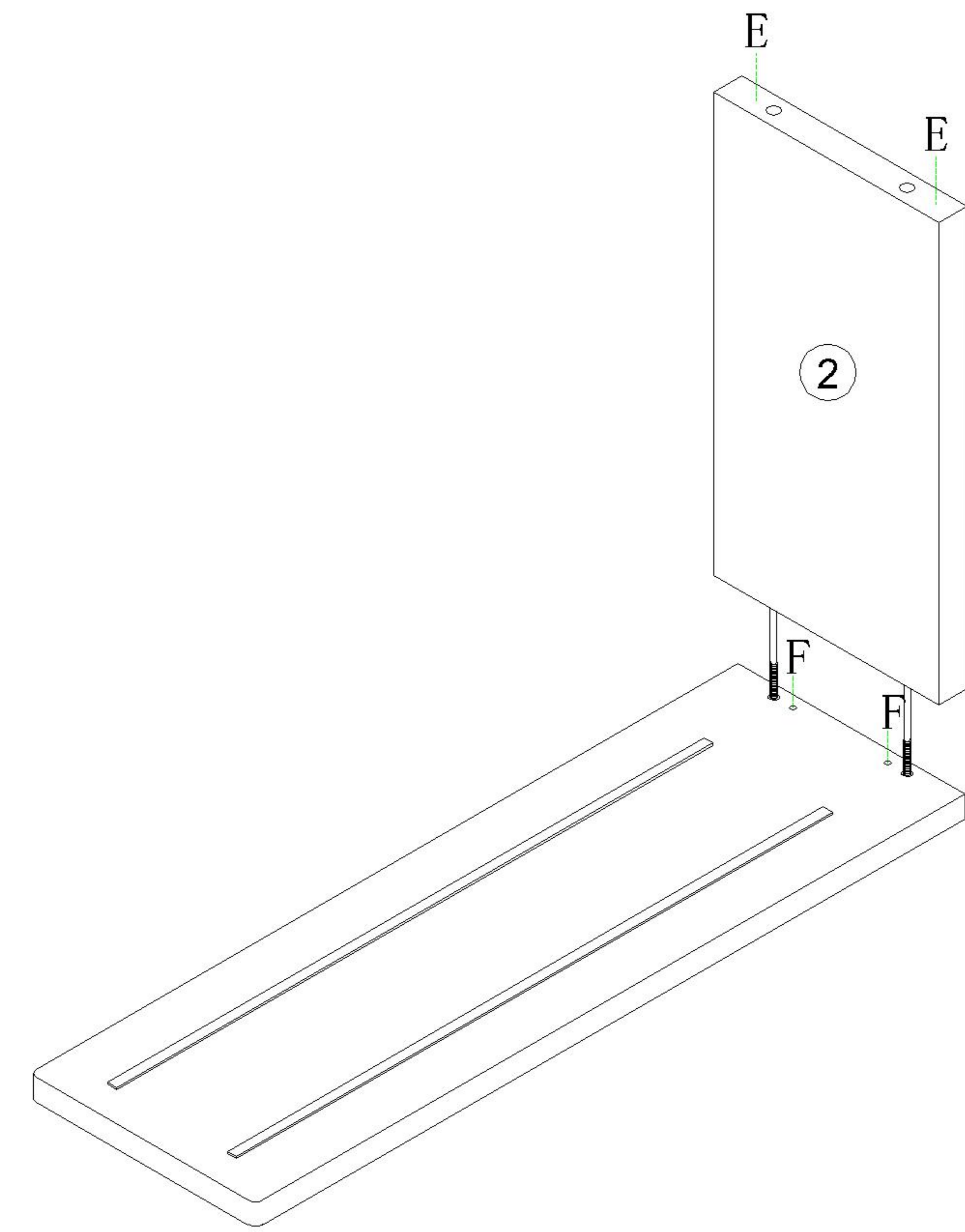

1

-  (E)\*2
-  (F)\*2



2

-  (A)\*2
-  (B)\*2
-  (C)\*1

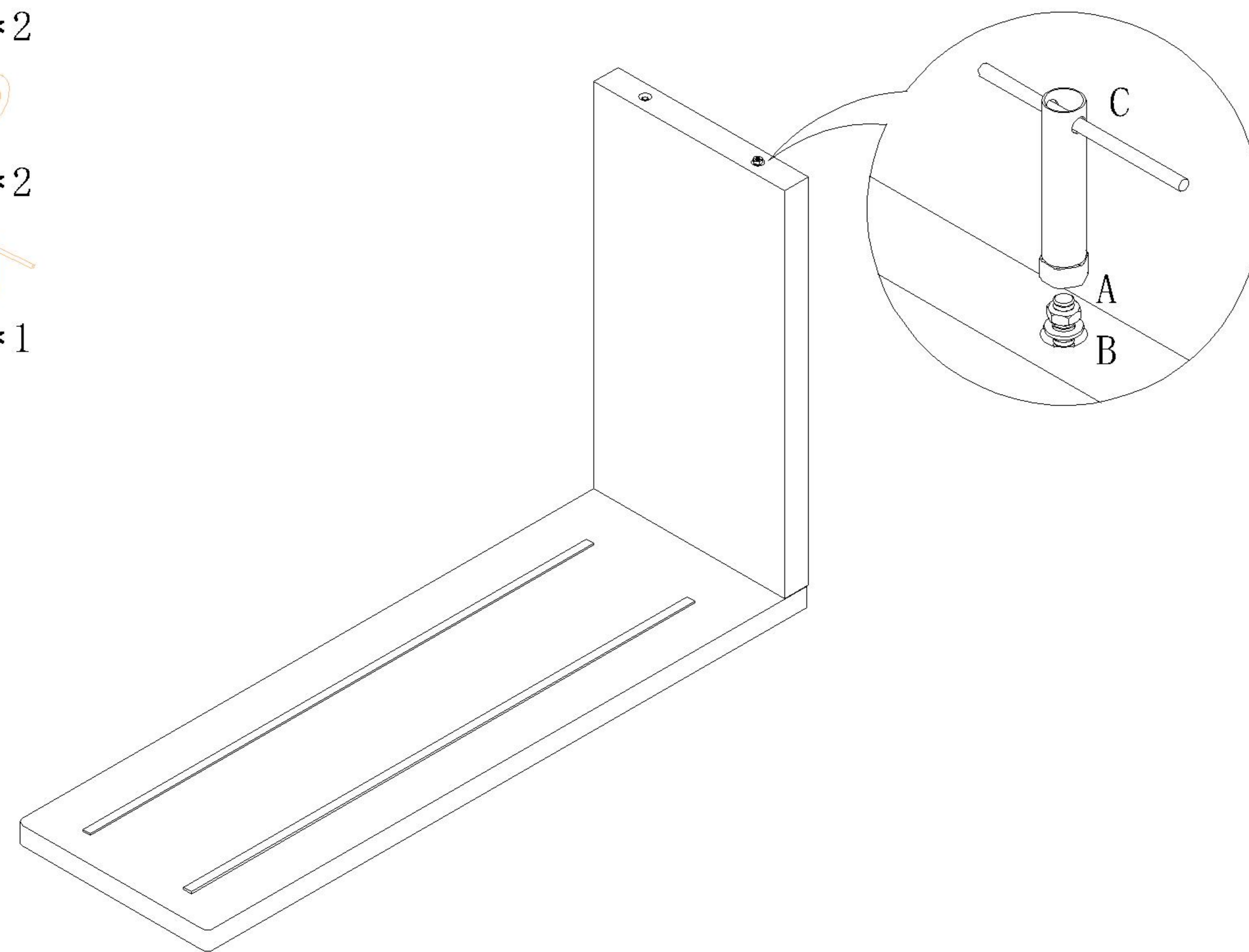

3

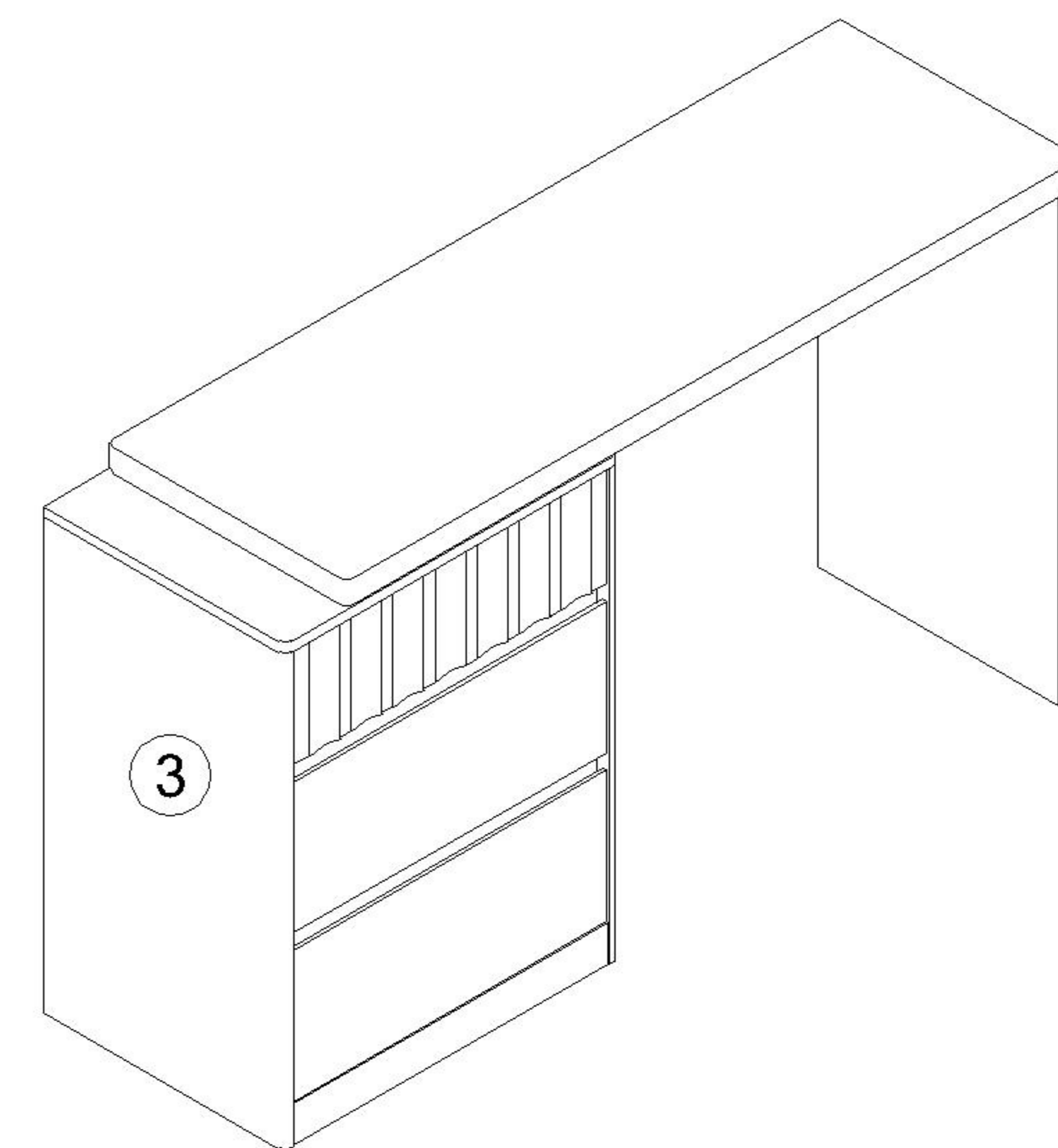

请根据所选产品搭配使用  
Please use it in combination  
with the selected product

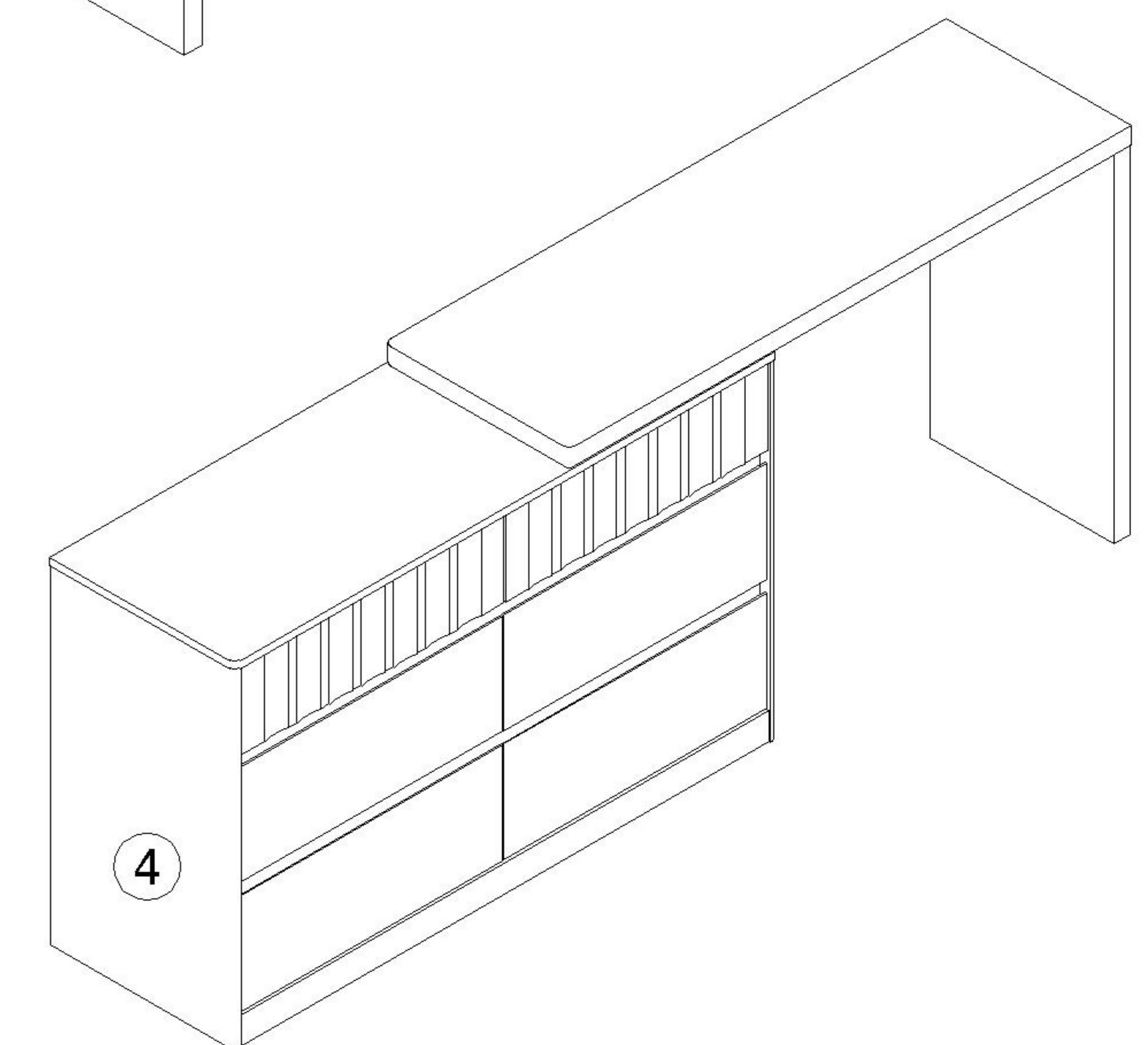

4