

LINSY 林氏家居

五金表/Hardware list

部件表/Parts List

安装示意图/Assembly Instruction

产品名称 Model NO.

LS724P7-A









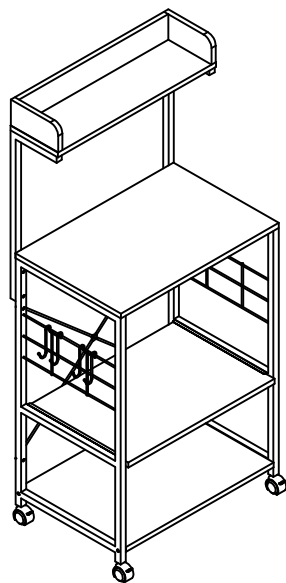

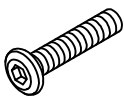
产品规格 Specification

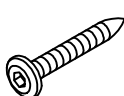
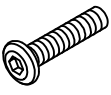
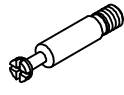
600x420x1370mm

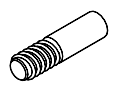
安装工具 Tool

安装人数 Installer

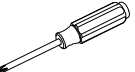

 A*4 1.5寸带刹小轮子 1.5 inch small wheel with brake	 B*4 M6X45螺丝 M6x45 screw	 C*8 M6带帽螺母 M6 cap nut	 D*10 Φ5X50螺丝 Φ5X50 Screw
 E*8 M6X30螺丝 M6x30 screw	 F*2 三合一螺丝 Three in one screw	 G*4 M6X28螺丝 M6x28 screw	 H*2 M6定位螺丝 M6 set screw
 I*2 双S长挂勾 Double s long hook	 J*1 M10扳手 M10 wrench	 K*1 M12 扳手 M12 wrench	 L*1 M13 扳手 M13 wrench
 M*1 M4 Z型扳手 M4 Z-type wrench	 N*1 十字螺丝刀 Cross screwdriver		

编号NO.	名称Name	规格Specification	数量QTY	材质Material
1	高腿焊接架左 High leg welding frame left	810X398X20	1	铁Iron
2	高腿焊接架右 High leg welding frame right	810X398X20	1	铁Iron
3	七字焊接组 Chevron welding group	545X172X20	2	铁Iron
4	下底板 Lower base plate	560X400X16t	1	刨花板 Particleboard
5	顶板 Roof	600X400X16t	1	刨花板 Particleboard
6	上层侧板左 Upper side plate left	180X84X16t	1	刨花板 Particleboard
7	上层侧板右 Upper side plate right	180X84X16t	1	刨花板 Particleboard
8	上层背板 Upper backplane	566X84X16t	1	刨花板 Particleboard
9	上层底板 Upper floor	600X180X16t	1	刨花板 Particleboard
10	交叉铁线 Cross wire	Φ5.4X784	1	铁Iron
11	导轨板 Guide plate	555X380X16t	1	刨花板 Particleboard

LS724P7-A

安装方法
Installation
method

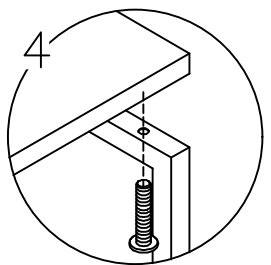
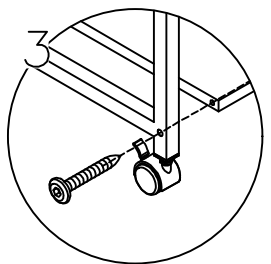
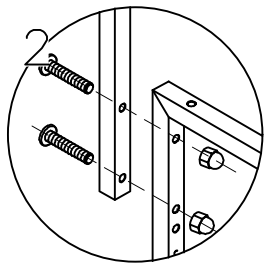
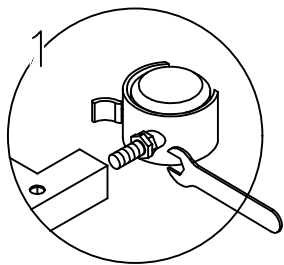

(A)*4

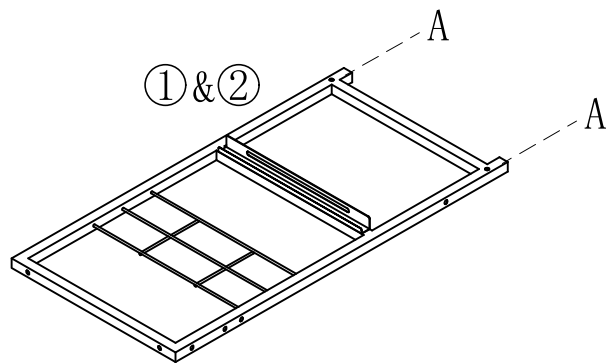

用L(#13扳手)卡轮子上大的螺母，
把轮子拧紧到侧架上，避免架子高低不平

Use L (# 13 wrench) to clamp the large nut on the wheel,
Tighten the wheels onto the side frame to avoid uneven
height of the frame

1



(B)*4



(C)*4

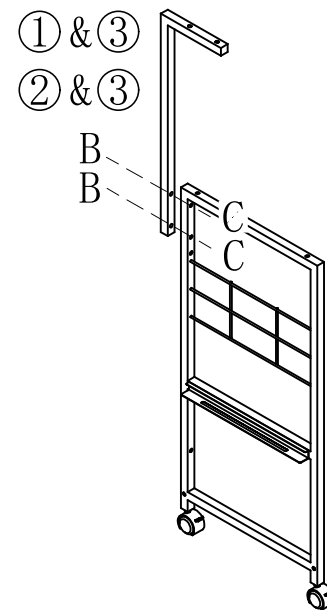

2



(D)*4

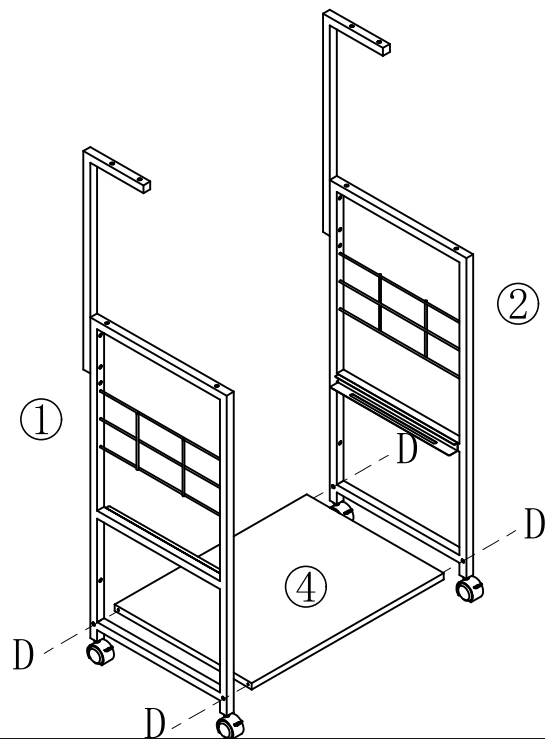

3



(E)*4

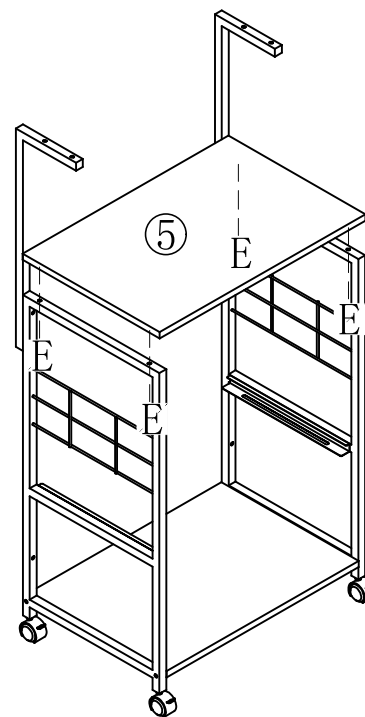

4

LS724P7-A

安装方法
Installation
method

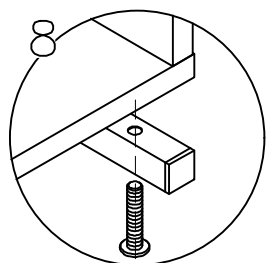
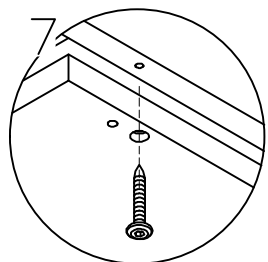
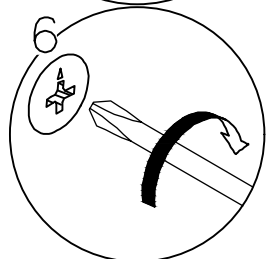
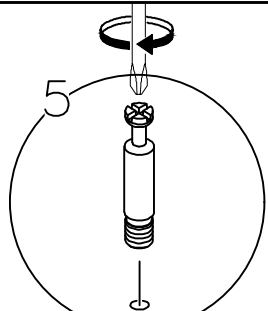

(F)*2

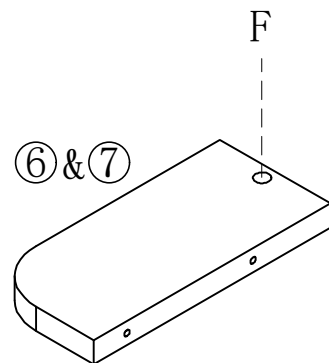

5

6

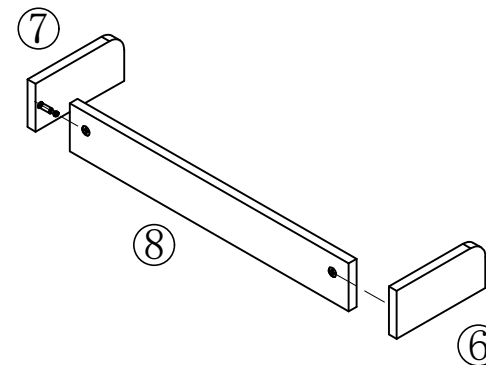

(D)*6

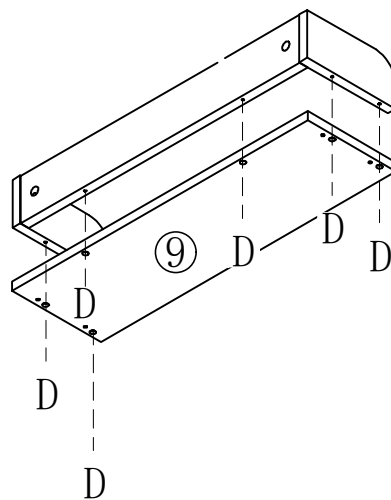

7

8



(E)*4

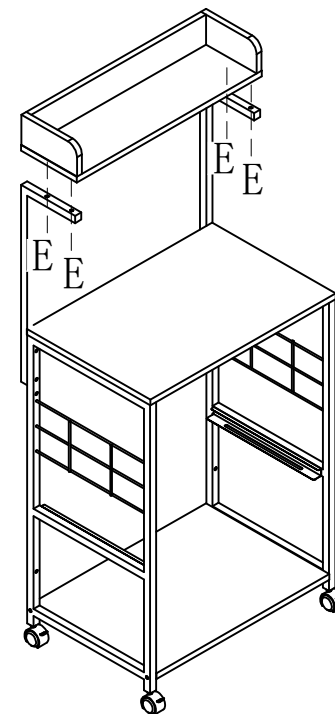

安装⑨号部件上层底板时,白板带内嵌螺母一面应朝下安装。

When installing the upper bottom plate of component ⑨, the whiteboard with embedded nuts should be installed facing downwards.

LS724P7-A

安装方法
Installation
method

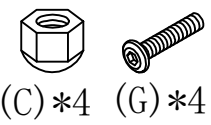
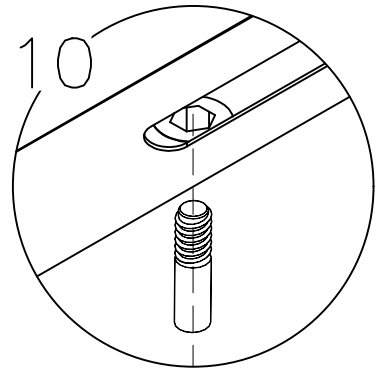
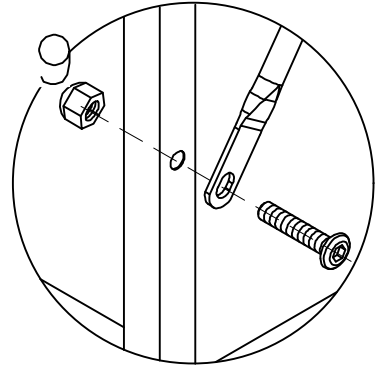

(C)*4 (G)*4

安装⑩号部件时, 请注意观察螺丝孔处的凹口方向, 凹口朝向外侧, 平口朝内安装。

When installing component ⑩, please pay attention to the screw holes. The direction of the notch is towards the outside, with the notch facing outwards and the flat mouth facing outwards. Internal testing installation.

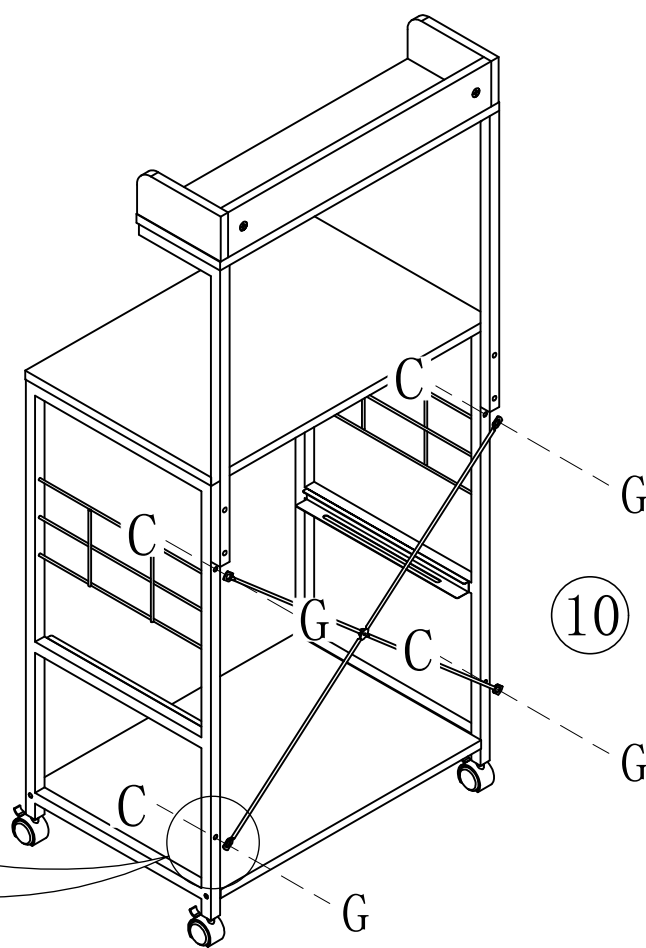
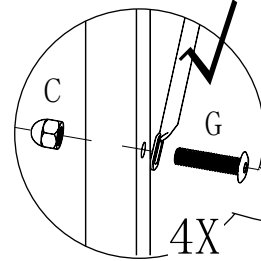
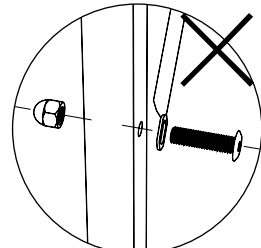

安装G螺丝和C螺帽时, 先不要拧紧螺丝, 全部固定好之后再统一拧紧。

When installing G screws and C nuts, do not tighten the screws first. After fixing everything, tighten them uniformly.

9

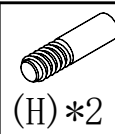

(H)*2

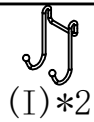
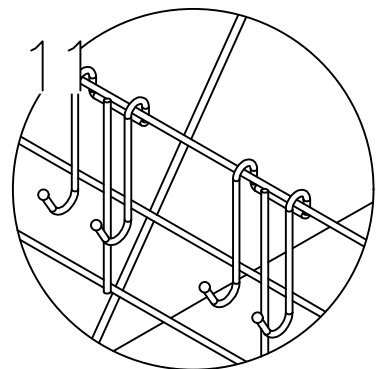
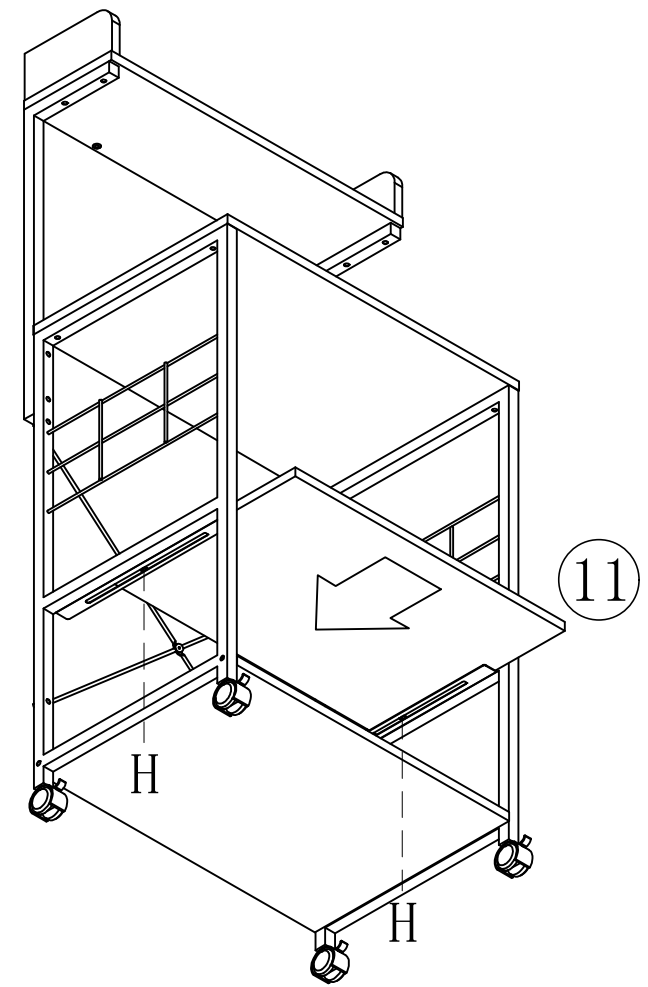

(I)*2

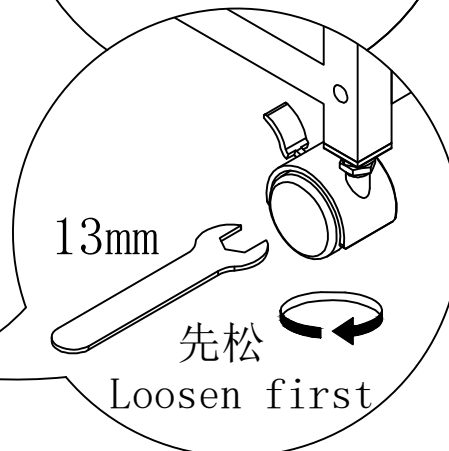
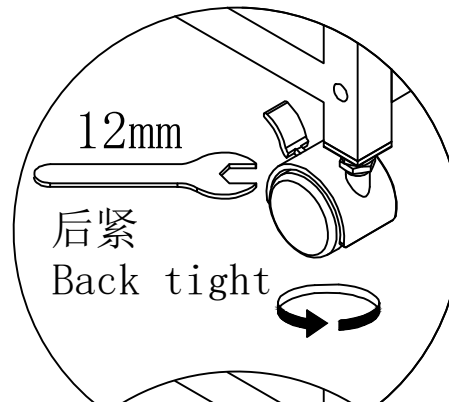
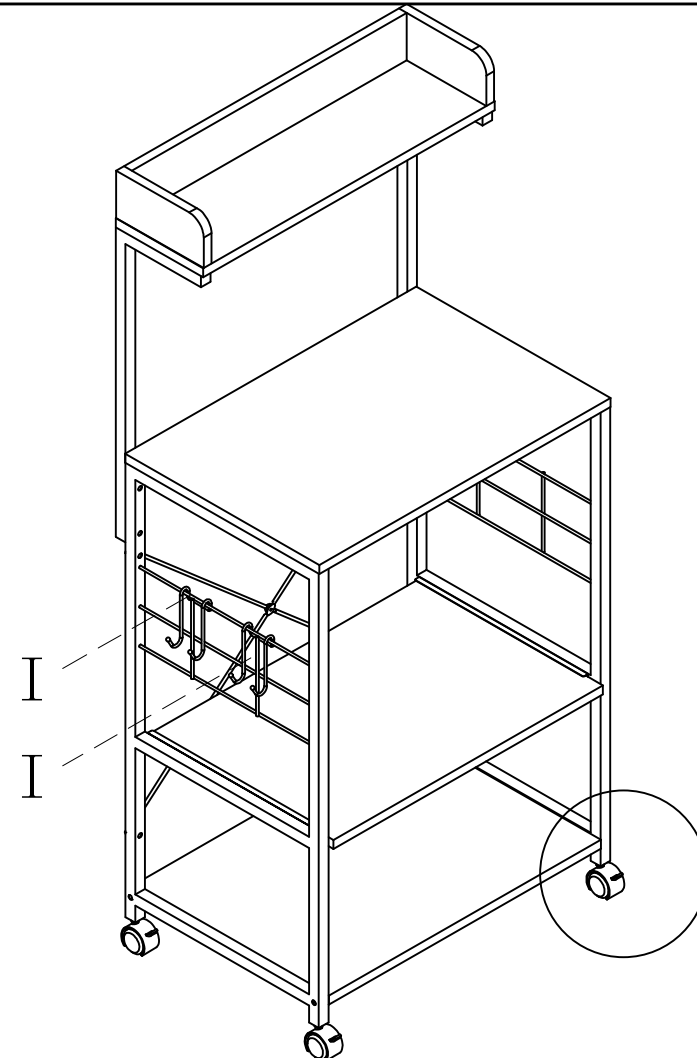

地板不平的情况而引起轮子不着地的话, 可通过用13mm扳手拧松轮子, 调整到适合高度, 然后通过用12mm扳手来向上锁紧定位螺母即可。If the wheel does not touch the ground due to the uneven floor, loosen the wheel with a 13mm wrench and adjust it to a suitable height, and then lock the locating nut with a 12mm wrench.

10

11