

MPE

Heat Seal Machinery & Tooling 



I-R1

ALL ELECTRIC Semi-Automatic Rotary Tray Sealer

UK/Europe Specification Sheet

MPE

MPE UK Ltd

Unit 18 Botany Business Park

Whaley Bridge, Derbyshire SK23 7DQ

+44 (0)1663 732700

sales@mpe-uk.com www.mpe-uk.com

Standard Features Include:

- **E-RAM** Sealing Technology, designed specifically to give maximum seal force with minimum maintenance and superior reliability / life-span
- **Environmentally Friendly ALL ELECTRIC** machine designed to reduce energy consumption
- Remote viewing and technical support via wireless modem link
- **FREE** direct software upgrades upon release
- Recipe driven automatic machine set up
- Process control monitoring
- Category 3 Safety System
- Up to 15 Cycles per minute with seal only applications
- Gas Flushing ready (cycles depending on product)
- 1-4 Impression Tooling with optional colour coding
- Simplistic manual tool change
- Film snap detection system
- Active film torque system
- Intuitive and customizable HMI design
- Ancillary Equipment Integration (Coders, Printers etc.)
- Phase monitoring protection to prevent surge damage to electrical components

Optional Features Includes

- Registered film Arrangement
- High Oxygen (High O₂) gas flush for applications such as red meat
- Inboard trim and Close cut film tooling options
- Modular tooling option







MPE

+44 (0)1664 732700

sales@mpe-uk.com www.mpe-uk.com

Sealing Capacities & Throughput Calculator

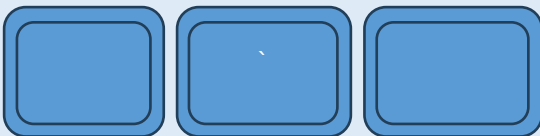
Achievable number of
Packs Per Minute PPM
by application type

# of Trays or Impressions per Cycle	Maximum tray dimension per impression number Maximum tray height is 105mm across all formats	Seal ONLY 15 CPM	Gas Flush 12 CPM	
1	 320mm (W) x 265mm (L)	 320mm (Ø)	15	12
2	 265mm (W) x 150mm (L)	 265mm (Ø)	30	24
3	 150mm (W) x 125mm (L)	 125mm (Ø)	45	36

MPE

+44 (0)1663 732700

sales@mpe-uk.com www.mpe-uk.com

Length

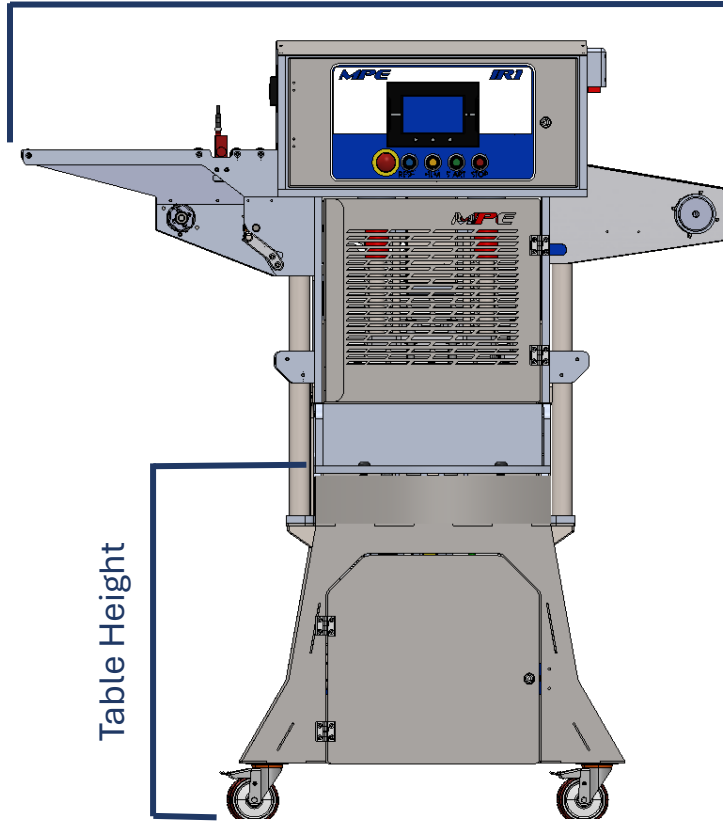
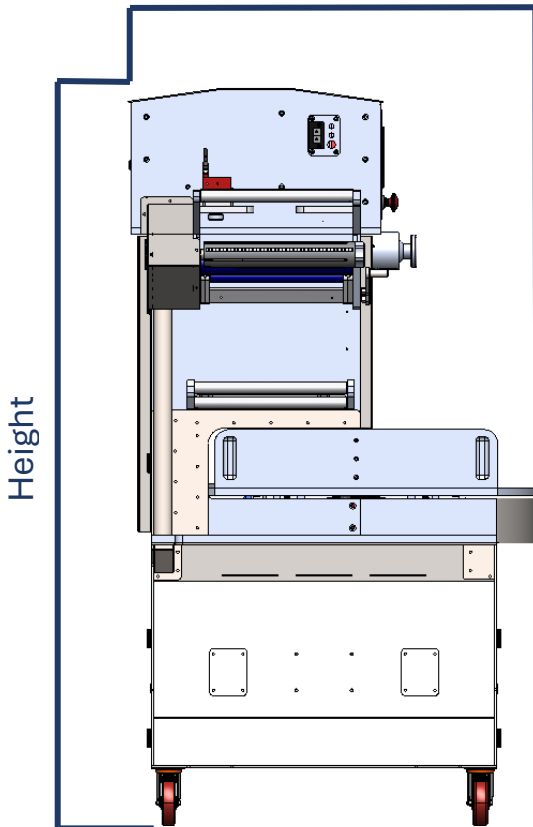

Table Height

Width



Height

SPECIFICATIONS

DIMENSIONS	MM	INCHES	FEET & INCHES
Length	1795	70.66	5' 9"
Width	1100	43.30	3' 6"
Height	2000	78.74	6' 5"
Table Height	914	35.98	3' 0"
POWER	415VAC 3P+N 16AMP		
REMOTE CONNECTION	WIFI or CAT 6		

MPE

+44 (0)1663 732700

sales@mpe-uk.com www.mpe-uk.com