



**EXTERNAL TPMS
SENSORS
TEH-1 AND TEL-1**

FITTING INSTRUCTIONS



BEFORE YOU BEGIN

Fitting external sensors to inner wheels?

If using an extension, please make sure it is a good quality, flexible extension which is clamped to the wheel.

STEP-BY-STEP FITTING GUIDE

Preparing and planning to fit the external TPMS sensors:

- 1.** Remove the dust cap from the tyre valve.
- 2.** Check the tyre pressure meets manufacturer recommendations - and adjust using an air compressor if required. This step is essential because, once fitted, the sensor will recognise the current pressure as being the target pressure. The target pressure is based on normal cold operating temperatures and is recommended by the vehicle manufacturer.
- 3.** Prior to fitting the TPMS sensor, check the pressure valve stem to ensure it is not damaged and is free from any contaminants.
- 4.** **OPTIONAL:** If using the anti-theft nuts, attach these to the tyre valve by screwing the nut onto the valve stem. Ensure enough thread is left so that the TPMS sensor can be fully screwed onto the valve stem.
- 5.** Twist the Wheely-Safe TPMS sensor onto the valve stem, finger tight. The sensor will flash red three times to confirm it has calibrated to the pressure of the tyre.
- 6.** **OPTIONAL:** If fitting the anti-theft nuts, use the lock nut spanner provided to tighten the nut back up towards the TPMS sensor until tight. During this process, hold the TPMS Sensor in place to stop it moving. We recommend the lock nut spanner is kept in the vehicle, to ensure any anti-theft nuts can be safely removed, and replaced again, in the event of tyres being changed.

PLEASE NOTE: If you wish to change your pressures at a future date (i.e. to switch between pressure recommendations for light/heavy loads), the act of removing the sensor, inflating/deflating your tyre to the appropriate level, and then refitting the TPMS sensor, will reset the target pressure. The sensor will flash red three times to confirm it has calibrated to the new target pressure of the tyre.

PLEASE NOTE: The TPMS Sensors will need to pair to the vehicle's receiving equipment following initial fitment. It is recommended you take the vehicle for a minimum 10 minute journey after fitting the system to ensure pairing of the TPMS sensors to the receiving equipment is completed.

CARE AND MAINTENANCE

1. TPMS sensors should be kept clean to allow visibility of flashing warnings.

2. As part of the periodic vehicle maintenance schedule, we recommend the following activities:

- a.** The tyre valve should be cleaned and checked for any corrosion.
- b.** Check that the internal gasket of the TPMS sensor is still in place and in good condition.
- c.** The gasket should be replaced if required, following the simple guide below.

Gasket replacement:

1. Spare gaskets aren't supplied, but if the original gasket (which fits inside the internal stem) becomes damaged or perished, please contact Wheely-Safe to source a spare. They can be quickly and easily replaced.

2. Remove the gasket from inside the TPMS sensor using a pin or small screwdriver, and dispose of it responsibly.

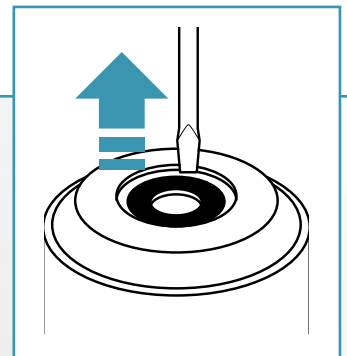

3. Replace the gasket with the spare.

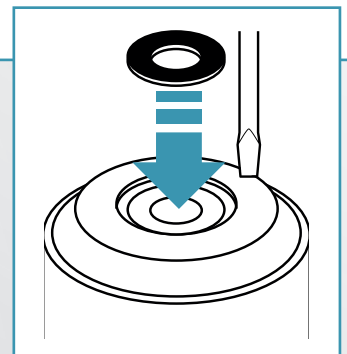

4. Ensure the tyre is inflated to the correct pressure.

5. Refit the TPMS sensor.

TECHNICAL ASSISTANCE

If you have any queries regarding the installation or use of this product please contact Wheely-Safe directly:

info@wheely-safe.co.uk

IMPORTANT INFORMATION

It is imperative that all staff/personnel be aware that even with the Wheely-Safe system fitted, normal tyre and wheel inspection, removal, maintenance and walkaround procedures/policies must still be adhered to.

No liability can be offered by Wheely-Safe Ltd for any loss or damages incurred as a result of the devices being fitted.

For further technical information, please refer to the product's technical specification.

WARRANTY

All Wheely-Safe products are covered by a comprehensive 12-month warranty, beginning from the date of purchase.

We encourage you to ensure that all parts are fitted by a competent person in accordance with manufacturer specifications. Wheely-Safe Ltd cannot be held liable for any damage caused by the fitting of a Wheely-Safe component.

Please ensure that you have read your warranty conditions before attempting to install the Wheely-Safe system, or repair an item on your vehicle. Wheely-Safe Ltd cannot be held responsible if an item is damaged or your warranty is voided. Please be aware that some manufacturer guarantees may be on the condition that you use a qualified technician for the installation of any ancillary equipment.

PRODUCT DISCLAIMER

The Wheely-Safe system is designed as a driver assistance device and should not be used as a substitute for regular manual wheel and tyre safety checks.

- Neither the seller, nor the manufacturer, will be liable for any loss, damage or injury, directly or indirectly arising from the use or inability to determine the use of this product.
- Before fitting, the user shall determine the suitability of the product for its intended use, and the user shall assume all responsibility and risk in connection herewith.
- The driver/operator is always responsible for the condition of the wheels/tyres on their vehicle and regular pre-use visual checks are essential to stay wheel and tyre safe.
- All tyres/wheels, including pressures, should be checked before any journey, when tyres are in their cold state, using an accurate tyre pressure gauge.
- When checking pressures, it is recommended all tyres receive a thorough inspection, checking tread depths and looking for any tyre damage or uneven wear. Wheel nuts, studs and rims should also be checked to ensure they are damage free and in a suitable condition prior to commencing the journey.

Published product details, specifications and suitability information is the best available at the time of publication. Wheely-Safe Ltd shall not be held responsible for the accuracy of any advice given regarding the suitability (or otherwise) of any part(s).

