



SE
series

OFFLINE OIL CLEANER



Triple R
INDUSTRIAL SERVICES

www.ditech.no

Effectively remove particles, water and varnish!

The SE series manufactured by Triple R Oil Cleaner | TRIS have been designed to purify and keep oil perfectly clean for applications with a system volume of approx. 6000 litres. The system ensures effective removal of all dirt particles, condensation and oxidation products (varnish) that cannot be removed with conventional filters

How it works

The SE system is connected as a bypass and has its own motor-pump combination, making the SE series system suitable for pressureless applications. The SE pumps the oil through the filter housing, then back to the tank via a pressureless return.

Benefit

- Prevents defects in hydraulic systems
- Improves the reliability & productivity of your machines
- Extends the life of all hydraulic components, such as pumps, servo valves and seals
- Extends the life of the oil
- Extends the service life of standard filter
- Reduces maintenance costs
- Reduces oil consumption
- Reduces machine downtime

Technology

The oil is forced axially through the filter element by the motor-pump combination, with pressureless return.

The SE system is available in a range of models, including mobile configurations



1st stage

big particles are retained on the top of the filter

2nd stage

small particles are trapped in the mid stage of the filter element

3rd stage

the smallest particles are trapped in the lower and compressed part of the filter.

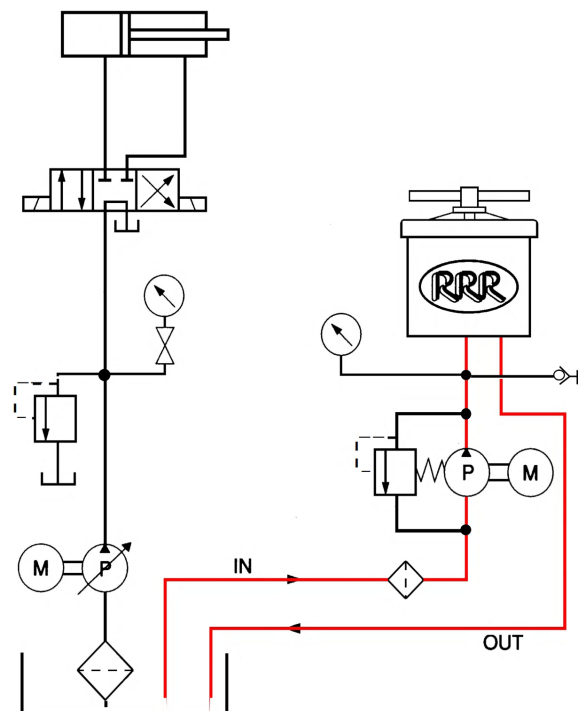

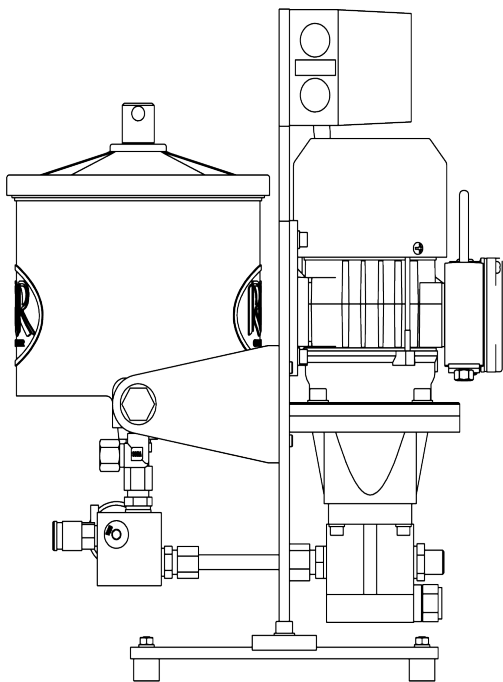

SE 100 BASIC version

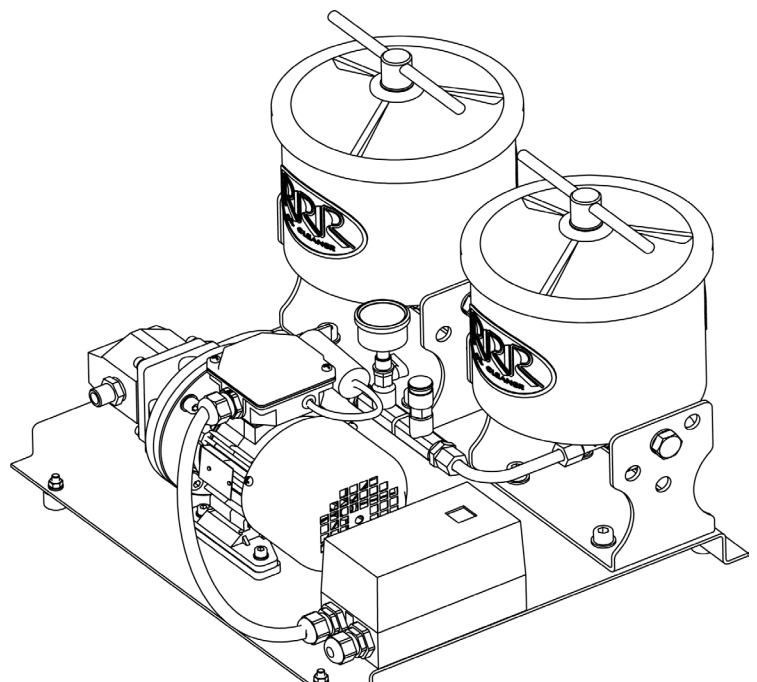

SE 200 BASIC version

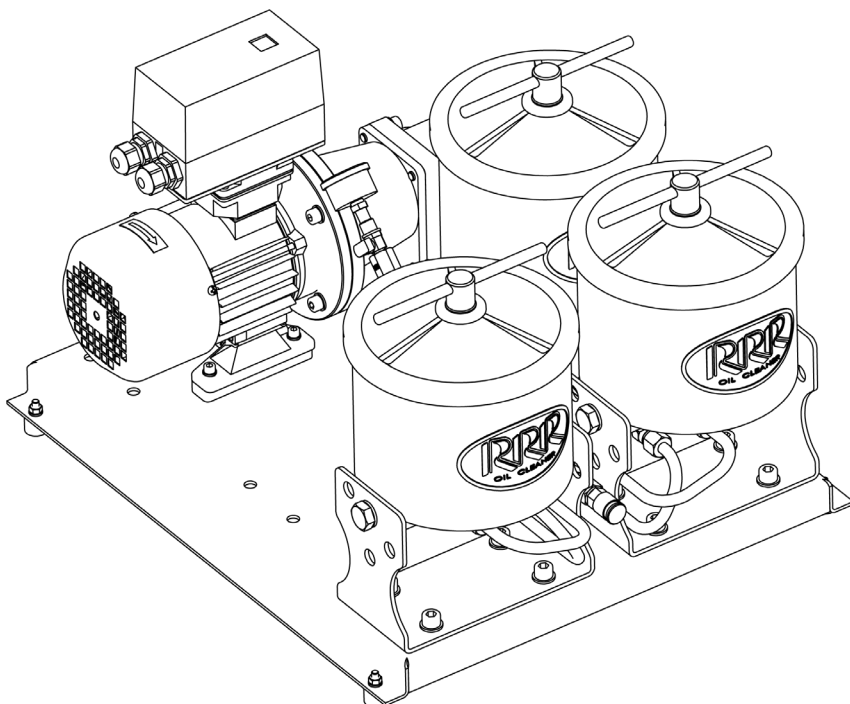

SE 300 BASIC version

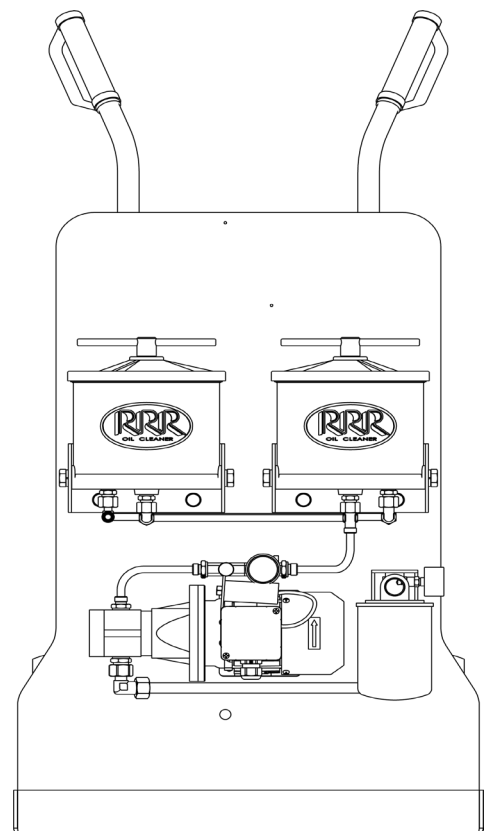

SE 200 MOBILE version

Products may vary for different fluid types, more information available at www.tris.pro

www.ditech.no

TRIPLE R OIL CLEANER: SE SERIES SELECTION CHART FOR HYDRAULIC AND LUBRICATION OILS

		APPROX. HYDAULIC OIL VOLUME BASED ON MAX 180cSt						
		< 500L	< 750L	< 1500L	< 2250L	< 3000L	< 4500L	> 4500L
TRIPLE R SYSTEM FOR YOUR APPLICATION	MODEL							
	SE-50	Green						
	SE-100	Light Green	Green					
	SE-200		Light Green	Green				
	SE-300			Light Green	Green			
	SE-400				Light Green	Green		
	SE-600					Light Green	Green	
OSCA series						Light Green	Green	

		APPROX. LUBRICATION OIL VOLUME BASED ON MAX 460cSt						
		< 250L	< 375L	< 750L	< 1125L	< 1500L	< 2250L	> 2250L
TRIPLE R SYSTEM FOR YOUR APPLICATION	MODEL							
	SE-50	Green						
	SE-100	Light Green	Green					
	SE-200		Light Green	Green				
	SE-300			Light Green	Green			
	SE-400				Light Green	Green		
	SE-600					Light Green	Green	
OSCA series						Light Green	Green	







TRIPLE R OIL CLEANER: SE SERIES SPECIFICATIONS AND FILTERELEMENT SELECTION CHART
TRIPLE R SE SERIES SYSTEM SPECIFICATIONS

MODEL	Hydraulic oil version pump capacity	Lubrication oil version pump capacity	Dimensions (mm)	Material
SE-50	~ 1.6L/min	N.A.	~ 363 x 230 x 460	Aluminium
SE-100	~ 2.5L/min	~ 1.2L/min	~ 385 x 230 x 460	Aluminium
SE-200	~ 5L/min	~ 2.5L/min	~ 470 x 400 x 370	Aluminium
SE-300	~ 7.5L/min	~ 3.3L/min	~ 610 x 470 x 370	Aluminium
SE-400	~ 9L/min	~ 5L/min	~ 610 x 470 x 370	Aluminium
SE-600	~ 16L/min	~ 7.5L/min	~ 1080 x 470 x 370	Aluminium

TRIPLE R ELEMENT SELECTION CHART

MODEL	SE-50	SE-100	SE-200	SE-300	SE-400	SE-600
# of elements	1	1	2	3	4	6

TRIPLE R ELEMENT SELECTION CHART

MODEL	D-100	E-100	E-100 SP	M-100	X-100	WE-100	WG-100
ARTICLE #	TR-20000	TR-20470	TR-20472	TR-20430	TR-25450	TR-20450	TR-25470
MICRON*	2	5	2	2	10	X	10
BETA	75	539	539	200	145	X	93
FLUID	hydraulic oil	hydraulic, engine oil, fuel	compressor fluids	hydraulic oil, fuels	lubrication oil	hydraulic, lubrication, engine oil	glycols
REMARKS	high dirt capacity					high water capacity	
IMAGE							

*All ratings are absolute ratings, multipass tested.

TRIPLE R OIL CLEANER: SE SERIES ORDER CODE GENERATOR, HOW TO ORDER

MODEL	HOUSING	VERSION	FLUID	GASKET	VOLTAGE	ON/OFF	SAMPLE
SE	TABLE 1	TABLE 2	TABLE 3	TABLE 4	TABLE 5	TABLE 6	TABLE 7

TABLE 1	CODE
Single house	50
Single house	100
Two housings	200
Three housings	300
Four housings	400
Six housings	600

TABLE 2	CODE
Basic (50-600)	B
Mobile (100, 200 & 400 only)	M
Wall mount (100, 200 & 300 only)	W

TABLE 3	CODE
Hydraulic	H
Lubrication	L
Fuels	F
Glycol	WG

TABLE 4	CODE
NBR GASKET (standard)	leave empty
VITON GASKET (pump and housing gaskets)	V

TABLE 5	CODE
110V single phase	110V
230V single phase	230V
400V three phase	400V

TABLE 6	CODE
Motor protection / On-Off (standard)	O
Without switch	leave empty

TABLE 7	CODE
Sample port (standard)	S
Without sample port	leave empty

COMPLETE EXAMPLE ORDER CODE*							
SE	100	B	H	V	230V	O	S

* more options and custom engineered systems are available, contact us for more information

**SE SERIES OFFLINE OIL CLEANERS ARE
PERFECT FOR:**

**Gas turbines
Steam turbines
Gearboxes
Mobile Hydraulics
Generators
Injection Moulding Machines
General Hydraulics
Fueltanks
Glycol fluids
Compressor fluids
& much more!**

**check out www.tris.pro for more information
or contact us: +31(0)742428109 info@tris.pro**

