



CONTACT US @ 855-355-2724

E-Mail: Sales@brahelectric.com

www.Brahelectric.com

PRODUCT DATA SHEET



MAGNETIC CONTACTOR

Picture is for reference only,
Actual Kit may vary slightly

Voltage Selection Chart B3RT1025-XXXX

B3RT1025	120VAC
B3RT1025-1AB01	24VAC
B3RT1025-1AK61	120VAC
B3RT1025-1AP61	240VAC
B3RT1025-1AV61	480VAC

PART NUMBER – B3RT1025-1AV61:

BRAH Electric, aftermarket direct replacement contactors for Siemens 3RT1025-1AV61, Sirius line, type 3RT, 3P, 3PH, 17A, 600V, 5HP @ 230V, 10HP @ 460V, 15HP @ 575V, complete with 480V AC coil, AC magnetic contactor, suitable for use with 3RT series motor control systems

PRODUCT SPECIFICATIONS

Manufacturer	BRAH Electric
Sub-Category	Contactors
Phase	3
Poles	3
Voltage Max	600
Amperage Max	17
Coil Voltage Min	480
Coil Voltage Max	480
Min HP.Rating	5(HP) @230V
Max HP.Rating	15(HP) @575V

Warranty: All Products sold by BRAH Electric are guaranteed to be free of defect for a period of two years, under the condition that the product has been installed and operated properly. All items proven defective within the one year period will be replaced by BRAH Electric. In the event that we cannot provide a direct replacement, your monies will be refunded in full. We are not responsible for any consequential losses or damages outside of the defective product as well as any replacements or repairs performed by another party without our written authorization from BRAH Electric.

REVISIONS				
ZONE	REV.	DESCRIPTION	DATE	APPROVED

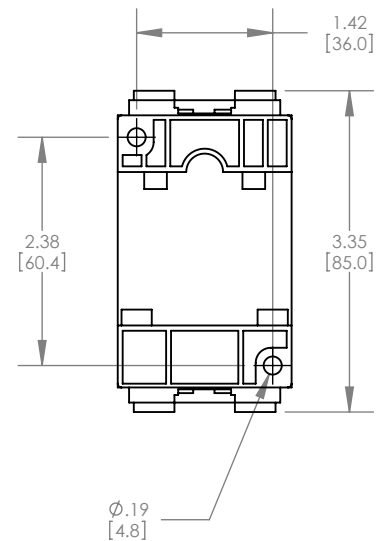
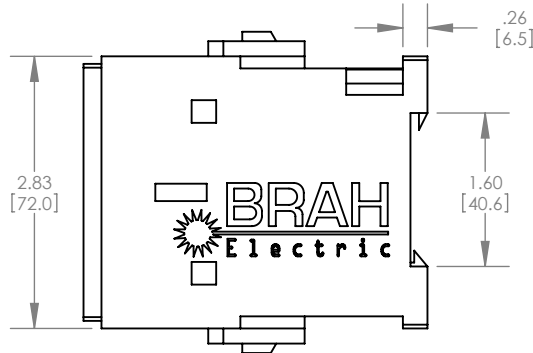
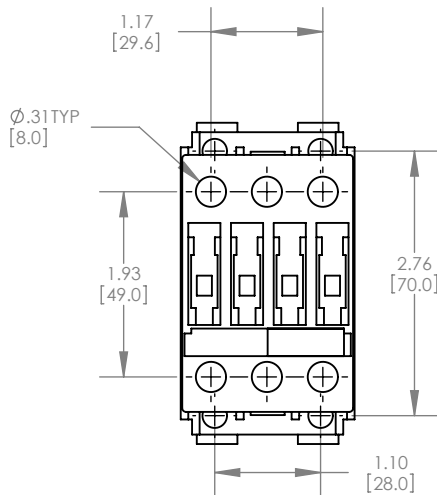
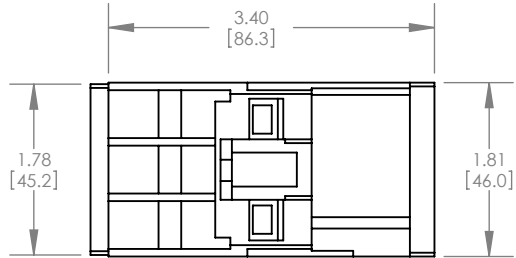
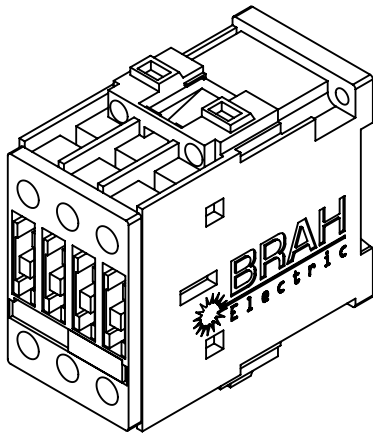

WWW.BRAHELECTRIC.COM, 855-355-2724

***NOTE: BRAH ELECTRIC CONTACTOR B3RT1025-1AV61 IS AN AFTERMARKET DIRECT REPLACEMENT FOR TELEMECANIQUE 3RT1025-1AV61,3RT SERIES. SUITABLE FOR USE WITH 3RT SERIES MOTOR CONTROL SYSTEMS**

 THIRD ANGLE PROJECTION PROPRIETARY AND CONFIDENTIAL THE INFORMATION CONTAINED IN THIS DRAWING IS THE SOLE PROPERTY OF BRAH ELECTRIC. ANY REPRODUCTION IN PART OR AS A WHOLE WITHOUT THE WRITTEN PERMISSION OF BRAH ELECTRIC IS PROHIBITED.	UNLESS OTHERWISE NOTED ALL DIMENSIONS ARE IN INCHES METRIC UNITS ARE DISPLAYED BENEATH IN [MM.]	 MAGNETIC CONTACTOR
	MATERIAL MOLDED PLASTIC CASE FINISH N/A DO NOT SCALE DRAWING	