



CONTACT US @ 855-355-2724

E-Mail: Sales@brahelectric.com

www.Brahelectric.com

PRODUCT DATA SHEET



coils

Picture is for reference only,
Actual Kit may vary slightly

PART NUMBER – B3RT1945-5AD01:

BRAH Electric, Sirius, direct substitute coil, type 3RT19, 42V AC 50Hz, suitable for use with 3RT1045, 3RT1046, 3RT1344, 3RT1346, 3RT1446 Contactors.

PRODUCT SPECIFICATIONS

Manufacturer	BRAH Electric
Sub-Category	Coils
Family	Sirius
Type	3RT19
Voltage	42
Suitable for	3RT1045, 3RT1046, 3RT1344, 3RT1346, 3RT1446

Warranty: All Products sold by BRAH Electric are guaranteed to be free of defect for a period of two years, under the condition that the product has been installed and operated properly. All items proven defective within the one year period will be replaced by BRAH Electric. In the event that we cannot provide a direct replacement, your monies will be refunded in full. We are not responsible for any consequential losses or damages outside of the defective product as well as any replacements or repairs performed by another party without our written authorization from BRAH Electric.

REVISIONS

ZONE	REV.	DESCRIPTION	DATE	APPROVED
------	------	-------------	------	----------

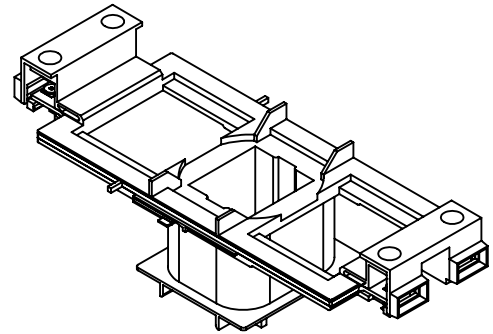

ISO VIEW

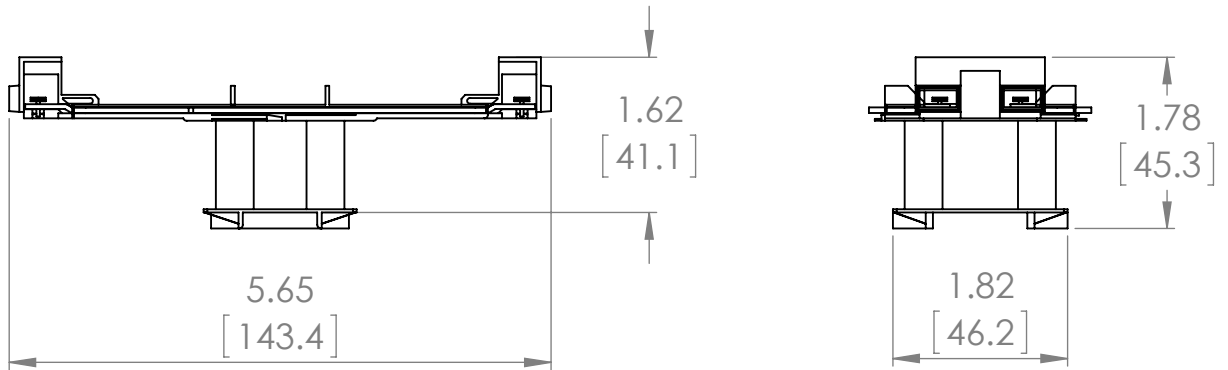
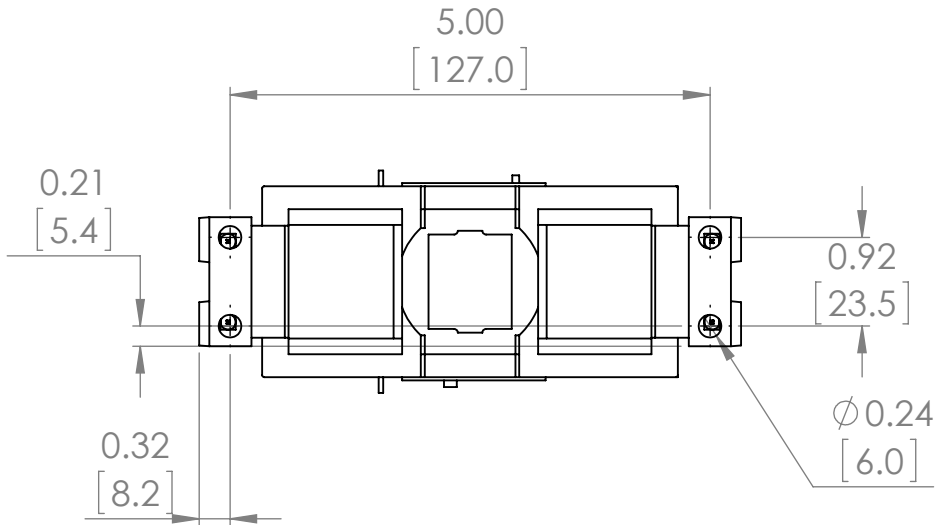

WWW.BRAHELECTRIC.COM, 855-355-2724

*NOTE: BRAH ELECTRIC COILS ARE A DIRECT REPLACEMENT FOR SIEMENS B3RT1945-5AD01, SIRIUS, TYPE B3RT, 42V AC 50Hz, SUITABLE FOR USE WITH 3RT1045, 3RT1046 CONTACTORS

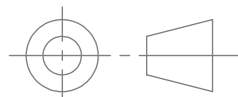

THIRD ANGLE PROJECTION

PROPRIETARY AND CONFIDENTIAL

THE INFORMATION CONTAINED IN THIS DRAWING IS THE SOLE PROPERTY OF BRAH ELECTRIC. ANY REPRODUCTION IN PART OR AS A WHOLE WITHOUT THE WRITTEN PERMISSION OF BRAH ELECTRIC IS PROHIBITED.

UNLESS OTHERWISE NOTED

ALL DIMENSIONS ARE IN INCHES
METRIC UNITS ARE DISPLAYED
BENEATH IN [MM.]

MATERIAL

FINISH

N/A

DO NOT SCALE DRAWING



MOTOR CONTROLS

SIZE	DWG. NO.	REV.
A	B3RT1945-5AD01	A
SCALE: 1:2	WEIGHT:	SHEET 1 OF 1