



CONTACT US @ 855-355-2724

E-Mail: [Sales@brahelectric.com](mailto:Sales@brahelectric.com)

[www.Brahelectric.com](http://www.Brahelectric.com)

## PRODUCT DATA SHEET

---



### Contactors

Picture is for reference only,  
Actual Kit may vary slightly

### **PART NUMBER- B3TB40:**

BRAH Electric, World series, contactor, type 3TB,3P  
3PH, 9A, 600V, 3HP@230V, 5HP@460V, 7.5@ 575V  
, complete with 110/120V coil, AC magnetic contactor,  
suitable for use with world series motor Control  
systems.

### **PRODUCT SPECIFICATIONS**

Manufacturer	BRAH Electric
Sub-Category	Contactors
Family	World Series
Type	3TB
Coil Voltage Min	110
Voltage	600
Coil Voltage Max	120
Amperage	9
Poles	3
Phase	3

**Warranty:** All Products sold by BRAH Electric are guaranteed to be free of defect for a period of two years, under the condition that the product has been installed and operated properly. All items proven defective within the one year period will be replaced by BRAH Electric. In the event that we cannot provide a direct replacement, your monies will be refunded in full. We are not responsible for any consequential losses or damages outside of the defective product as well as any replacements or repairs performed by another party without our written authorization from BRAH Electric.

REVISIONS				
ZONE	REV.	DESCRIPTION	DATE	APPROVED

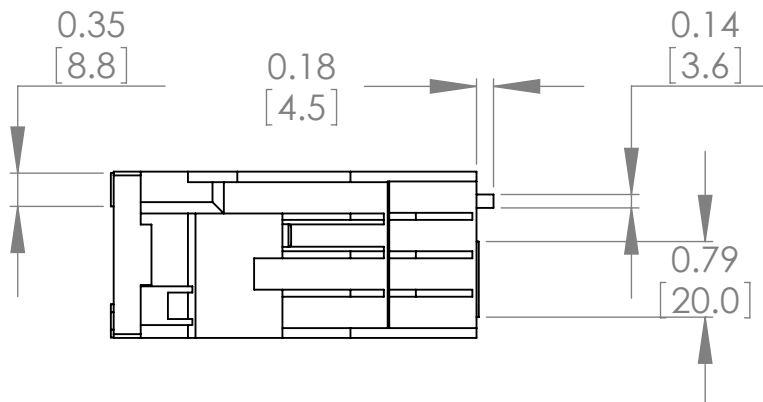
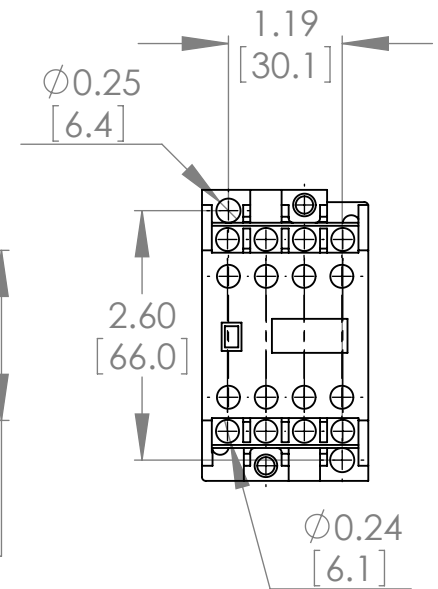
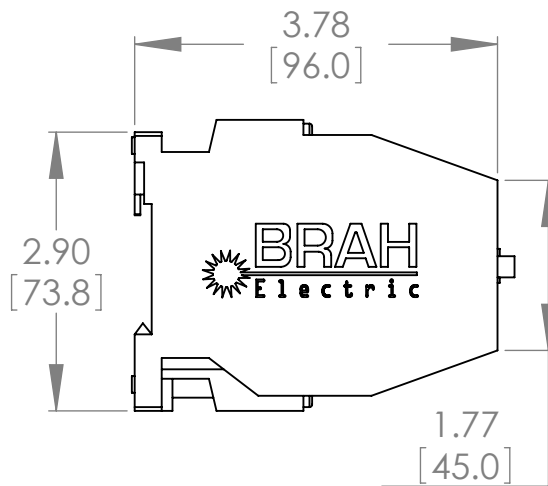
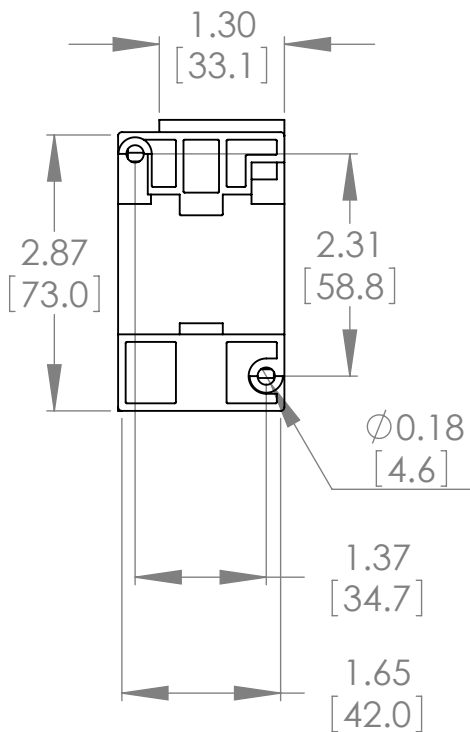
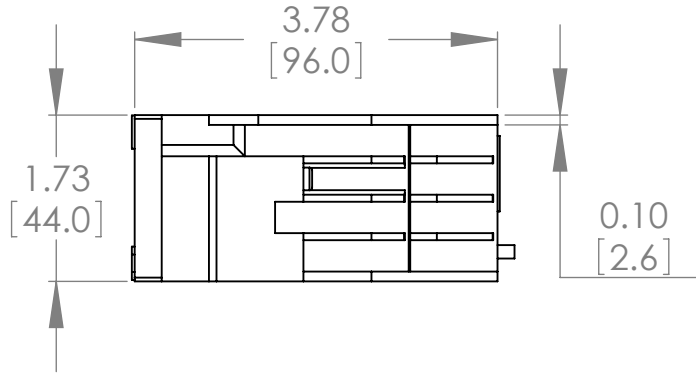
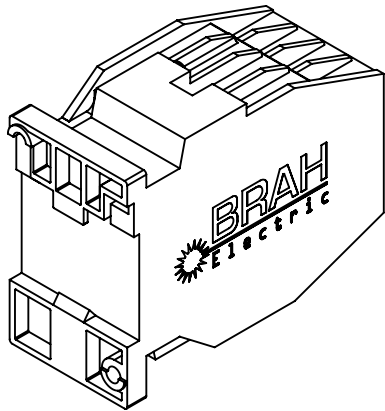

[WWW.BRAHELECTRIC.COM](http://WWW.BRAHELECTRIC.COM), 855-355-2724

\* NOTE: BRAH ELECTRIC CONTACTOR B3TB40 IS AN AFTERMARKET DIRECT REPLACEMENT FOR SIEMENS 3RTB40, 3TB SERIES. SUITABLE FOR USE WITH 3TB SERIES MOTOR CONTROL SYSTEMS

<p>THIRD ANGLE PROJECTION</p>	<p>UNLESS OTHERWISE NOTED ALL DIMENSIONS ARE IN INCHES METRIC UNITS ARE DISPLAYED BENEATH IN [ MM. ]</p>	<p><b>BRAH</b> Electric</p>
	<p>PROPRIETARY AND CONFIDENTIAL</p> <p>THE INFORMATION CONTAINED IN THIS DRAWING IS THE SOLE PROPERTY OF BRAH ELECTRIC. ANY REPRODUCTION IN PART OR AS A WHOLE WITHOUT THE WRITTEN PERMISSION OF BRAH ELECTRIC IS PROHIBITED.</p>	
<p>SIZE <b>A</b> DWG. NO. <b>B3TB40</b> REV. <b>A</b></p>		<p>SCALE: 1:2 WEIGHT: 3.2 LBS SHEET 1 OF 1</p>