

PRODUCT DATA SHEET



PART NUMBER – B3TF53: BRAH Electric, aftermarket direct replacement contactors for Siemens 3TF53, World Series, type 3TF, 3P, 3PH, 205A, 600V, 75HP @ 230V, 150HP @ 460V, 200HP @ 575V, complete with 110/120V AC coil, 2 N/O - 2 N/C auxiliary contact, AC magnetic contactor, suitable for use with 3TF series motor control systems

PRODUCT SPECIFICATIONS

MAGNETIC CONTACTOR
PART NO. B3TF53

**Voltage Selection Chart
B3TF53XXXX**

B3TF53	110/120V AC
B3TF5322	110/120V AC
B3TF5322-0AC2	24V AC
B3TF5322-0AK6	110/120V AC
B3TF5322-0AP6	240V AC
B3TF5322-0AV0	480V AC

	<i>TYPE</i>	<i>VALUE (UNITS)</i>	<i>NOTES</i>	<i>COMMENTS</i>
	PHASE	3		
	POLES	3		
	VOLTAGE	600 (VAC)		
	AMPERAGE	205 (A)		
	COIL VOLTAGE MIN	110 (V)		
	COIL VOLTAGE MAX	120 (V)		
	MIN HP. RATING	75 (HP)	@ 230V	
	MAX HP RATING	200 (HP)	@ 575V	

Warranty: All Products sold by BRAH Electric are guaranteed to be free of defect for a period of one year, under the condition that the product has been installed and operated properly. All items proven defective within the one year period will be replaced by BRAH Electric. In the event that we cannot provide a direct replacement, your monies will be refunded in full. We are not responsible for any consequential losses or damages outside of the defective product as well as any replacements or repairs performed by another party without our written authorization from BRAH Electric.

REVISIONS

ZONE	REV.	DESCRIPTION	DATE	APPROVED
------	------	-------------	------	----------

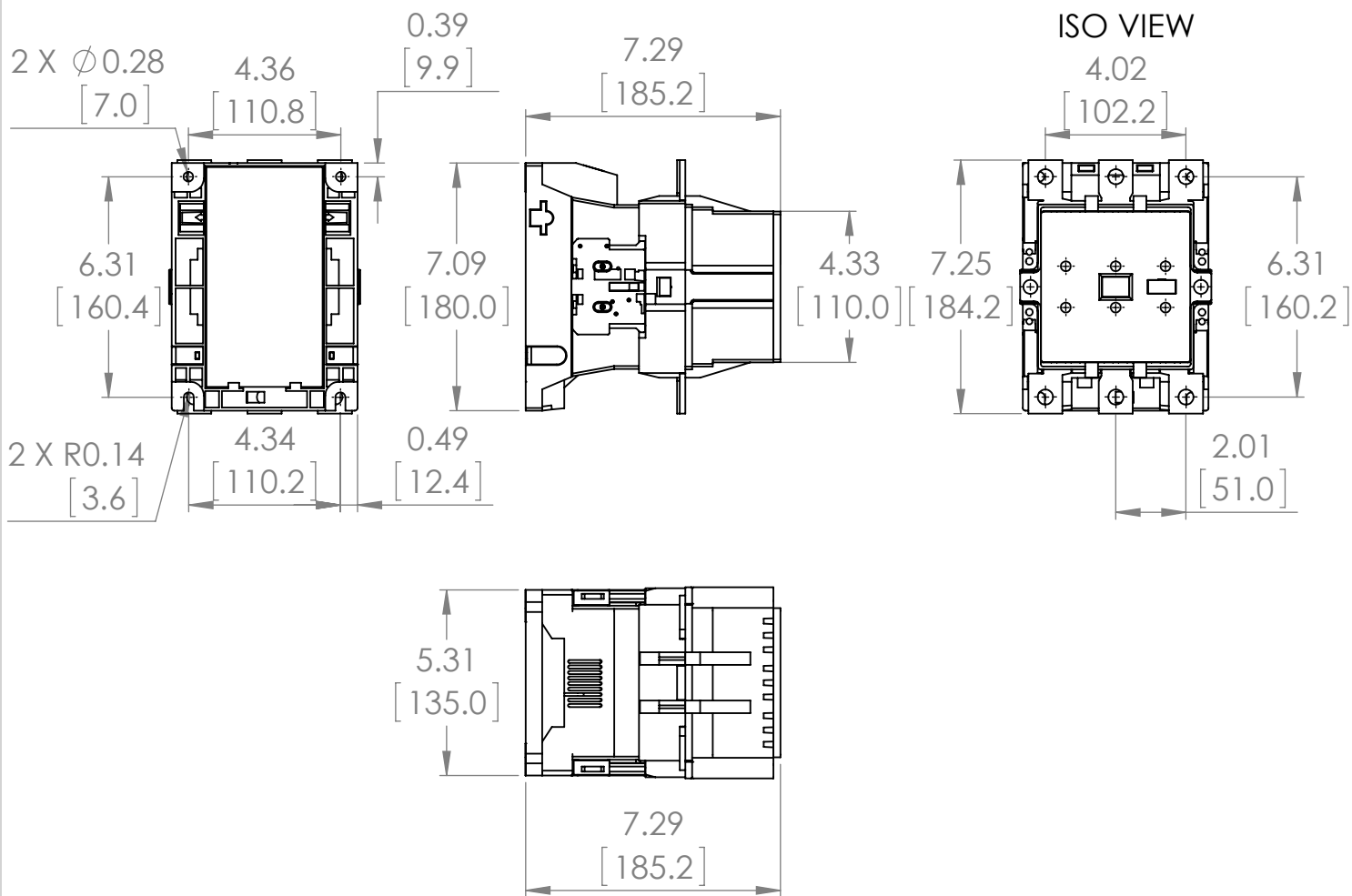
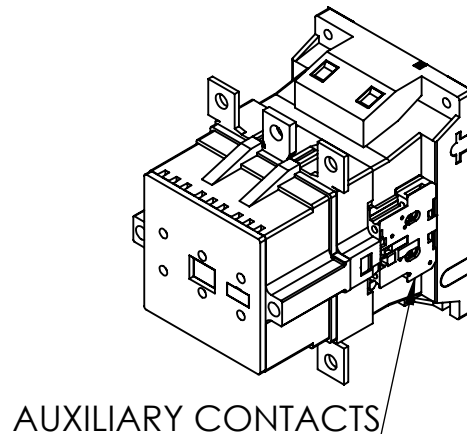
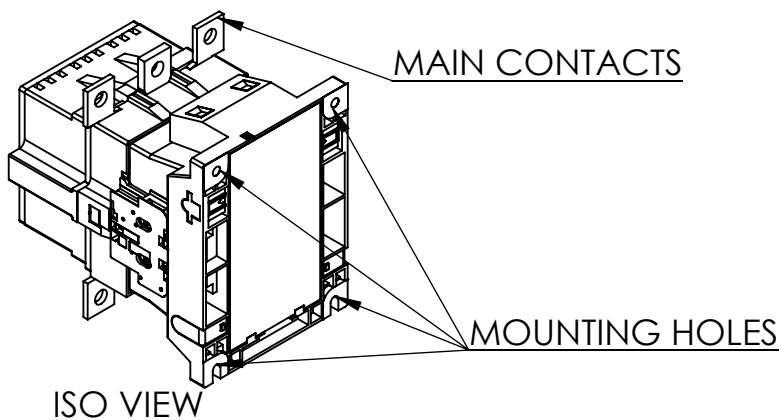

WWW.BRAHELECTRIC.COM, 855-355-2724

*NOTE: BRAH ELECTRIC CONTACTOR B3TF53 IS AN AFTERMARKET DIRECT REPLACEMENT FOR 3TF53,TF SERIES. SUITABLE FOR USE WITH TF SERIES MOTOR CONTROL SYSTEM.

<p>THIRD ANGLE PROJECTION</p>	<p>UNLESS OTHERWISE NOTED</p> <p>ALL DIMENSIONS ARE IN INCHES METRIC UNITS ARE DISPLAYED BENEATH IN [MM.]</p>			
	<p>PROPRIETARY AND CONFIDENTIAL</p> <p>THE INFORMATION CONTAINED IN THIS DRAWING IS THE SOLE PROPERTY OF BRAH ELECTRIC. ANY REPRODUCTION IN PART OR AS A WHOLE WITHOUT THE WRITTEN PERMISSION OF BRAH ELECTRIC IS PROHIBITED.</p>	<p>MATERIAL MOLDED PLASTIC CASE</p> <p>FINISH N/A</p> <p>DO NOT SCALE DRAWING</p>	<p>MAGNETIC CONTACTOR</p>	
<p>SIZE A DWG. NO. B3TF53 REV. A</p>		<p>SCALE:1:5</p>	<p>WEIGHT: 3.2 LBS</p>	<p>SHEET 1 OF 1</p>