



CONTACT US @ 855-355-2724

E-Mail: Sales@brahelectric.com

www.Brahelectric.com

PRODUCT DATA SHEET

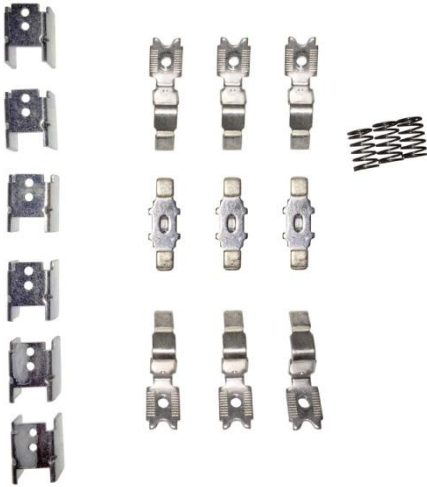

CONTACT KITS

Picture is for reference only,
Actual Kit may vary slightly

PART NUMBER- B6-65-2:

BRAH Electric direct replacement contact kit. 3 Pole, rated for 27 Amp, 600 Volt max, suitable for NEMA size 1 motor starters & contactors, suitable with Cutler Hammer Freedom Series model types AN16, AN30, AN40, AN70, AN80, AN800, CN15, CN35, CN55. Complete assembly kit includes all contacts and related mounting screws & hardware. Kit directly replaces Cutler Hammer OEM 6-65-2

PRODUCT SPECIFICATIONS

Manufacturer	BRAH Electric
Sub-Category	Contact Kits
Family	Freedom Series
Type	6-65
Type For	AN16, AN30, AN40, AN70, AN80, AN800, CN15, CN35, CN55
OEM Manufacturer	Cutler Hammer
OEM Part Number	6-65-2
Poles	3
Amperage Max	27
Voltage Max	600
NEMA size	1

Warranty: All Products sold by BRAH Electric are guaranteed to be free of defect for a period of two years, under the condition that the product has been installed and operated properly. All items proven defective within the one year period will be replaced by BRAH Electric. In the event that we cannot provide a direct replacement, your monies will be refunded in full. We are not responsible for any consequential losses or damages outside of the defective product as well as any replacements or repairs performed by another party without our written authorization from BRAH Electric.

REVISIONS				
ZONE	REV.	DESCRIPTION	DATE	APPROVED

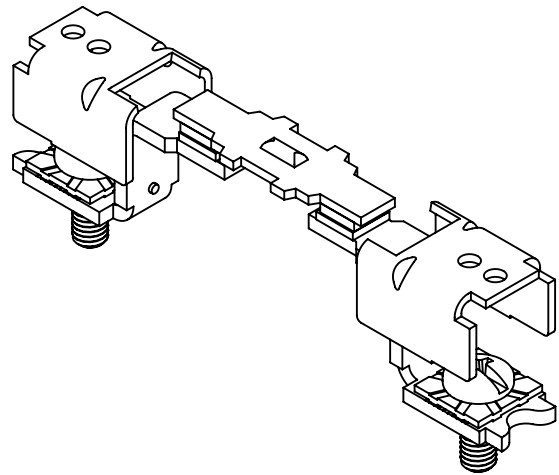
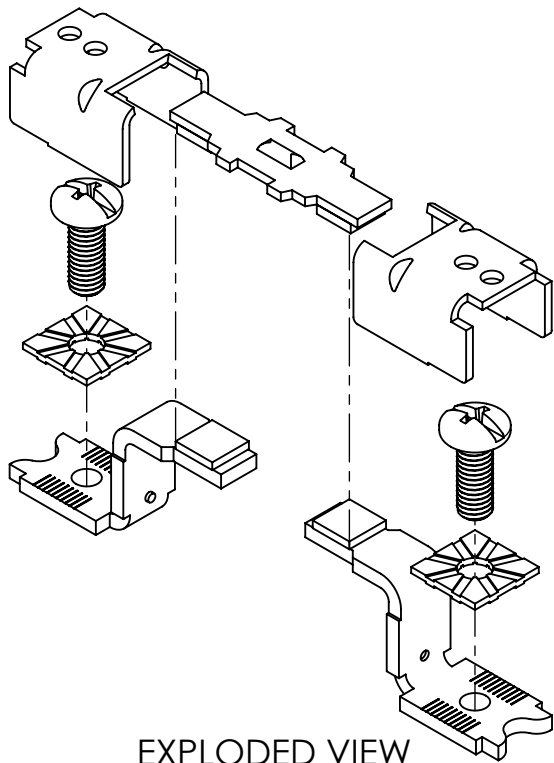

EXPLODED VIEW

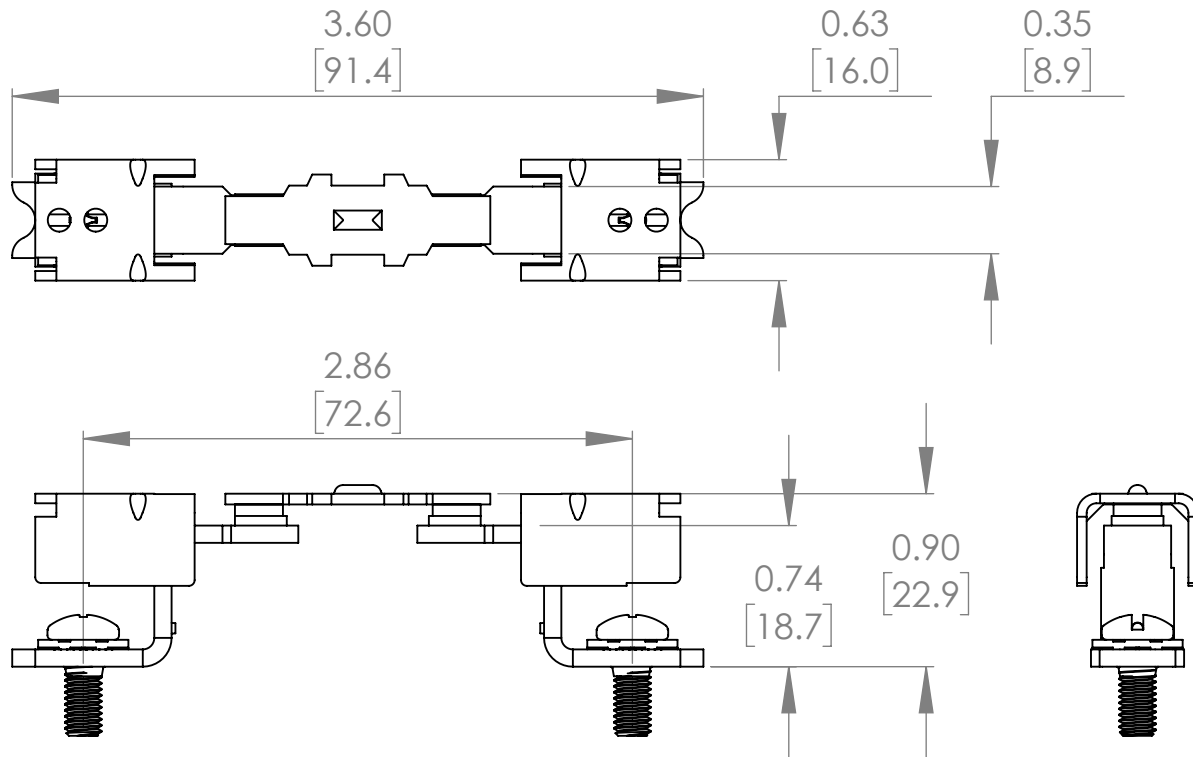

WWW.BRAHELECTRIC.COM, 855-355-2724

* NOTE: BRAH Electric, aftermarket direct replacement contact kits for Cutler Hammer, Freedom Series, B6-65, 3 pole kit, suitable for use with AN16, AN30, AN40, AN70, AN80, AN800, CN15, CN35, CN55 magnetic contactors & motor starters, NEMA size 1, rated for 27A 600V maximum

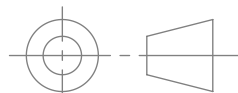

THIRD ANGLE PROJECTION

PROPRIETARY AND CONFIDENTIAL

THE INFORMATION CONTAINED IN THIS DRAWING IS THE SOLE PROPERTY OF BRAH ELECTRIC. ANY REPRODUCTION IN PART OR AS A WHOLE WITHOUT THE WRITTEN PERMISSION OF BRAH ELECTRIC IS PROHIBITED.

UNLESS OTHERWISE NOTED
ALL DIMENSIONS ARE IN INCHES
METRIC UNITS ARE DISPLAYED
BENEATH IN [MM.]

MATERIAL
N/A
FINISH
N/A
DO NOT SCALE DRAWING



CONTACT KIT

SIZE A	DWG. NO. B6-65-2	REV. A
SCALE: 1:1	WEIGHT: 3.2 LBS	SHEET 1 OF 1