



CONTACT US @ 855-355-2724

E-Mail: [Sales@brahelectric.com](mailto:Sales@brahelectric.com)

[www.Brahelectric.com](http://www.Brahelectric.com)

## PRODUCT DATA SHEET

---



Contact kits  
Picture is for reference  
only, Actual Kit may vary  
slightly

### **PART NUMBER-B75HF15:**

BRAH Electric, Direct replacement aftermarket conversion kit for Furnas 1 pole contact kit, rated for 44amp, 600volt max, suitable for IEC size H motor starters and contactors, suitable with Furnas Innova model types 15HF, 21HF, 23HF, 24HF, complete assembly kit includes all contacts and related mounting screws and hardware, direct substitute for Furnas OEM 75HF15

### **PRODUCT SPECIFICATIONS**

Manufacturer	BRAH Electric
Sub-Category	Contact Kit
Family	Innova
Type	75HF, B75HF
Suitable For	15HF, 21HF, 23HF, 24HF
Voltage	600
Amperage	44

**Warranty:** All Products sold by BRAH Electric are guaranteed to be free of defect for a period of two years, under the condition that the product has been installed and operated properly. All items proven defective within the one year period will be replaced by BRAH Electric. In the event that we cannot provide a direct replacement, your monies will be refunded in full. We are not responsible for any consequential losses or damages outside of the defective product as well as any replacements or repairs performed by another party without our written authorization from BRAH Electric.

REVISIONS				
ZONE	REV.	DESCRIPTION	DATE	APPROVED

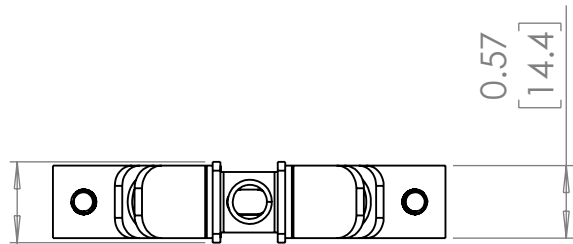
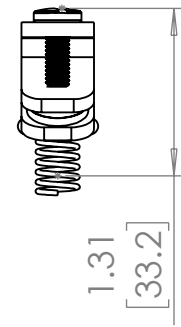
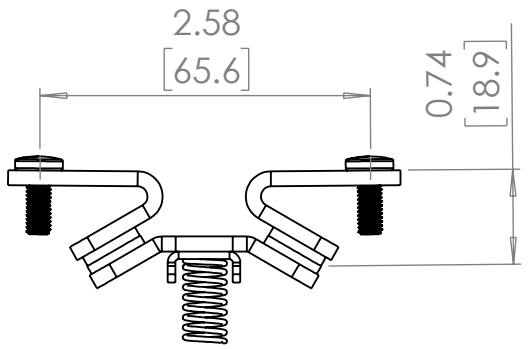
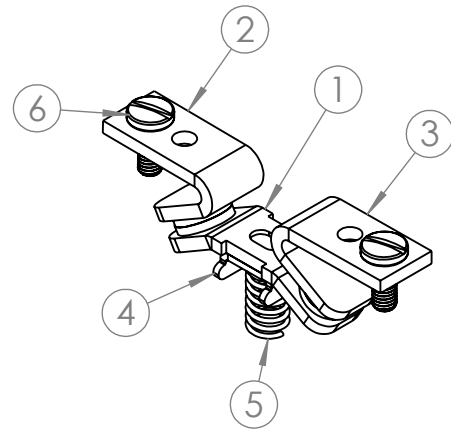
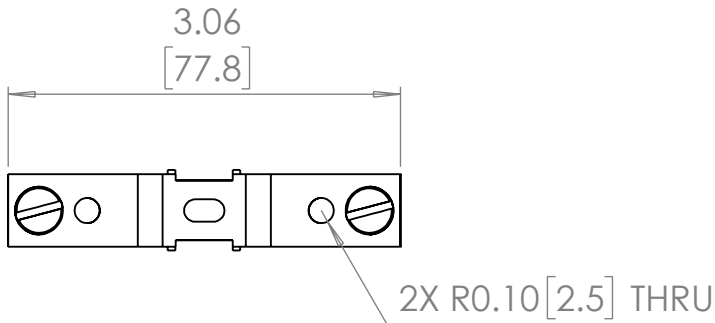

ITEM NO.	PART NUMBER	DESCRIPTION	VENDOR	QTY.
1	B75HF15	Contact Kit	BRAH	1
2	B75HF15 - 01-R	Contact Kit	BRAH	1
3	B75HF15 - 01-L	Contact Kit	BRAH	1
4	B75HF15 - 02	Contact Kit	BRAH	1
5	B75HF15 - Spring	Spring	BRAH	1
6	B75HF15 - Screw	10-32 UNF X 1/2 "	BRAH	2

\* NOTE: BRAH Electric, aftermarket direct replacement contact kits for Furnas Innova Series, Type B75HF, 1 pole kit, suitable for use with 15HF, 21HF, 23HF, 24HF magnetic contactors & motor starters, NEMA size 3, rated for 600V maximum of 90 Amp

THIRD ANGLE PROJECTION

**PROPRIETARY AND CONFIDENTIAL**

THE INFORMATION CONTAINED IN THIS DRAWING IS THE SOLE PROPERTY OF BRAH ELECTRIC. ANY REPRODUCTION IN PART OR AS A WHOLE WITHOUT THE WRITTEN PERMISSION OF BRAH ELECTRIC IS PROHIBITED.

UNLESS OTHERWISE NOTED  
ALL DIMENSIONS ARE IN INCHES  
METRIC UNITS ARE DISPLAYED  
BENEATH IN [ MM. ]

MATERIAL	N/A
FINISH	N/A
DO NOT SCALE DRAWING	

**CONTACT KIT**

SIZE <b>A</b>	DWG. NO. <b>B75HF15</b>	REV. <b>A</b>
SCALE: 1:2	WEIGHT: 0.017 LBS	SHEET 1 OF 1