

PRODUCT DATA SHEET



PART NUMBER – BLC1D0910-G7: BRAH Electric, aftermarket direct replacement contactors for Telemecanique LC1D0910-G7, TeSys D Series, type LC1D, 3P, 3PH, 25A, 600V, complete with 110/120V AC coil voltage max 5 hp, 1 N/O auxiliary contact, AC magnetic contactor, suitable for use with LC1-D series motor control systems.

PRODUCT SPECIFICATIONS

CONTACTORS

PART NO. BLC1D0910-G7

Manufacturer	BRAH Electric
Sub-Category	Contactors
Family	TeSys D
Type	BLC1D
Phase	3
Poles	3
Voltage	600
Amperage	25
Coil Voltage Max	5 (HP)

Warranty: All Products sold by BRAH Electric are guaranteed to be free of defect for a period of one year, under the condition that the product has been installed and operated properly. All items proven defective within the one year period will be replaced by BRAH Electric. In the event that we cannot provide a direct replacement, your monies will be refunded in full. We are not responsible for any consequential losses or damages outside of the defective product as well as any replacements or repairs performed by another party without our written authorization from BRAH Electric.

REVISIONS				
ZONE	REV.	DESCRIPTION	DATE	APPROVED

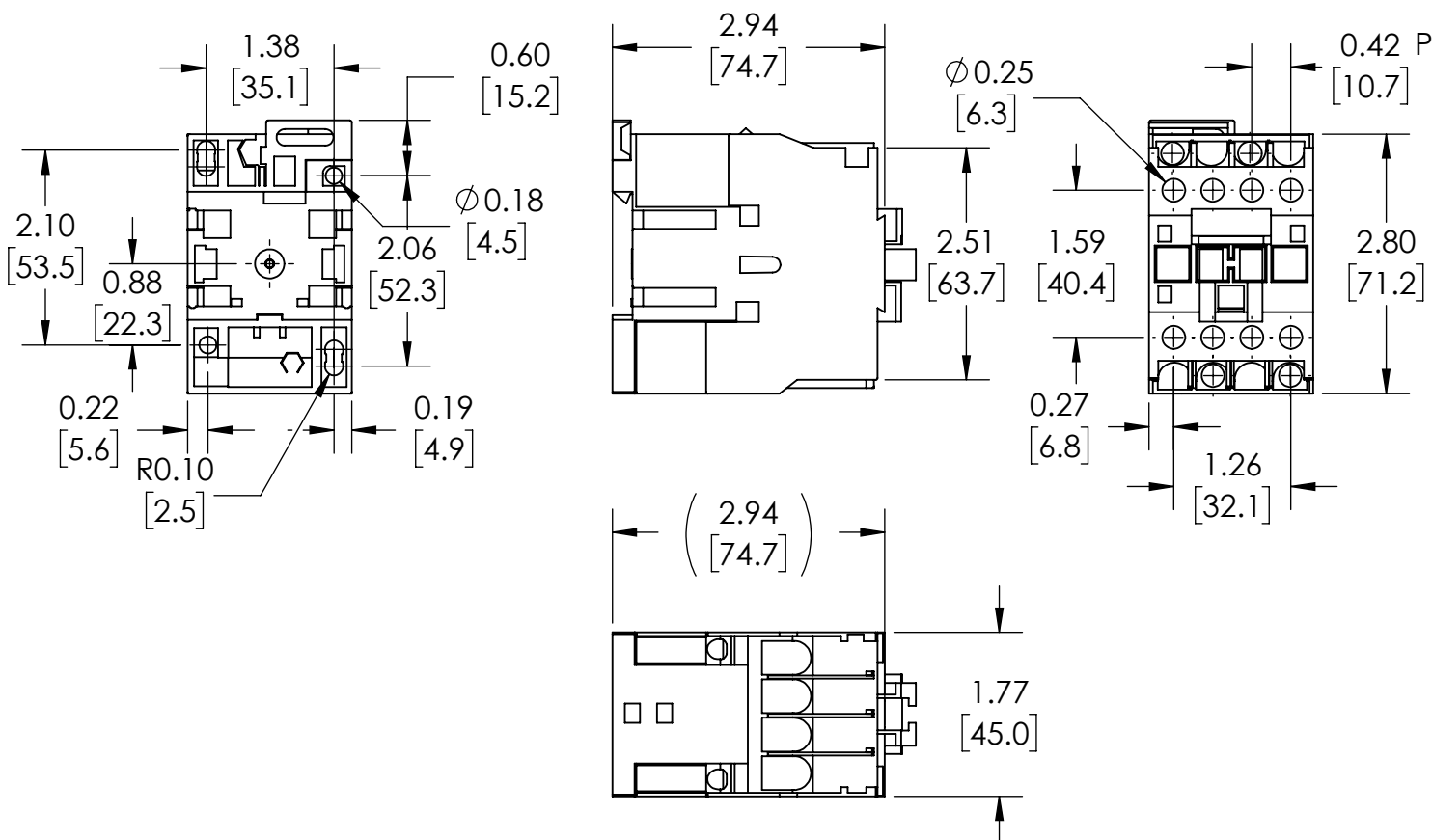

WWW.BRAHELECTRIC.COM, 855-355-2724

*NOTE: BRAH ELECTRIC CONTACTOR BLC1D0910-G7 IS AN AFTERMARKET DIRECT REPLACEMENT FOR LC1D0910-G7 SERIES. SUITABLE FOR USE WITH LC1-D SERIES MOTOR CONTROL SYSTEMS

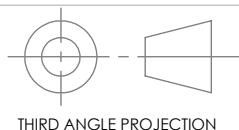

PROPRIETARY AND CONFIDENTIAL

THE INFORMATION CONTAINED IN THIS DRAWING IS THE SOLE PROPERTY OF BRAH ELECTRIC. ANY REPRODUCTION IN PART OR AS A WHOLE WITHOUT THE WRITTEN PERMISSION OF BRAH ELECTRIC IS PROHIBITED.

UNLESS OTHERWISE NOTED
ALL DIMENSIONS ARE IN INCHES
METRIC UNITS ARE DISPLAYED
BENEATH IN [MM.]

MATERIAL	MOLDED PLASTIC CASE
FINISH	N/A
DO NOT SCALE DRAWING	



MAGNETIC CONTACTOR

SIZE	DWG. NO.	BLC1D0910-G7	REV.	A
SCALE: 1:2	WEIGHT: 3.2 LBS	SHEET 1 OF 1		