

PRODUCT DATA SHEET



PART NUMBER – BLP1D8010BD: BRAH Electric, aftermarket direct replacement contactors for Telemecanique LP1D8010BD, TeSys D Series, type LP1D, 3P, 3PH, 125A, 600V, 30HP @ 240V, 60HP @ 480V, 60HP @ 600V, complete with 24V DC coil, 1 N/O auxiliary contact, DC magnetic contactor, suitable for use with LP1-D series motor control systems

PRODUCT SPECIFICATIONS

MAGNETIC CONTACTOR
PART NO. BLP1D8010BD

<i>TYPE</i>	<i>VALUE (UNITS)</i>	<i>NOTES</i>	<i>COMMENTS</i>
<i>PHASE</i>	3		
<i>POLES</i>	3		
<i>VOLTAGE</i>	600 (VAC)		
<i>AMPERAGE</i>	125 (A)		
<i>COIL VOLTAGE MIN</i>	24 (V)		
<i>COIL VOLTAGE MAX</i>	24 (V)		
<i>MIN HP. RATING</i>	30 (HP)	@ 240V	
<i>MAX HP RATING</i>	60 (HP)	@ 600V	

Warranty: All Products sold by BRAH Electric are guaranteed to be free of defect for a period of one year, under the condition that the product has been installed and operated properly. All items proven defective within the one year period will be replaced by BRAH Electric. In the event that we cannot provide a direct replacement, your monies will be refunded in full. We are not responsible for any consequential losses or damages outside of the defective product as well as any replacements or repairs performed by another party without our written authorization from BRAH Electric

REVISIONS				
ZONE	REV.	DESCRIPTION	DATE	APPROVED

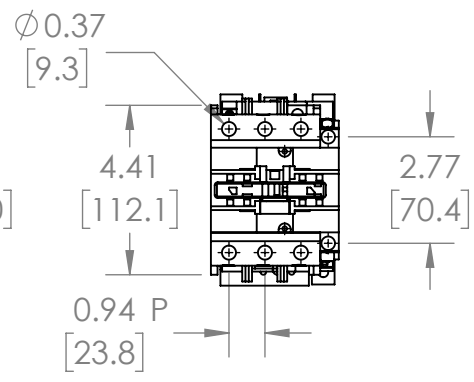
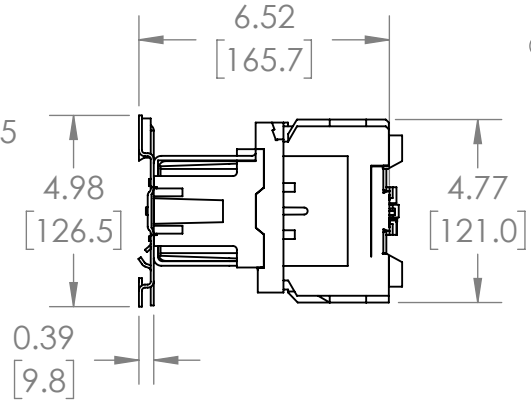
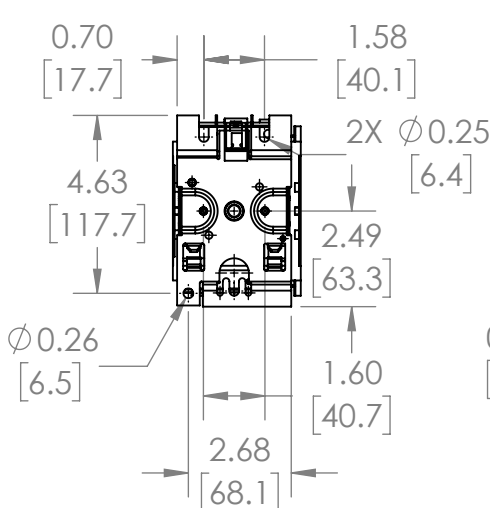
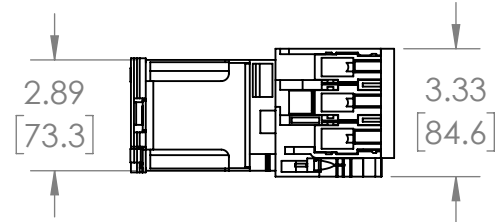
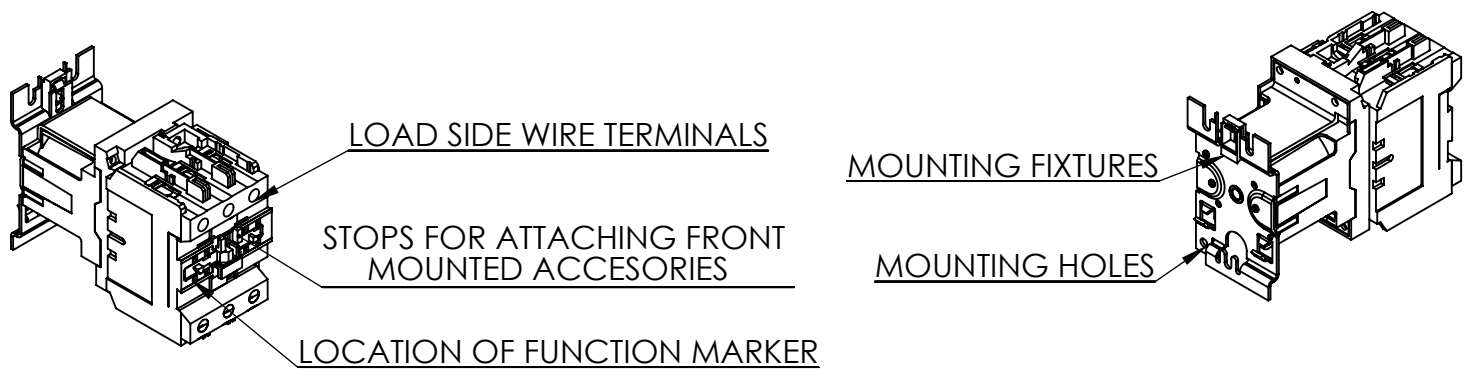

WWW.BRAHELECTRIC.COM, 855-355-2724

*NOTE: BRAH ELECTRIC CONTACTOR BLP1D8010BD IS AN AFTERMARKET DIRECT REPLACEMENT FOR LP1D8010BD, LP1-D SERIES. SUITABLE FOR USE WITH LP1-D SERIES MOTOR CONTROL SYSTEMS

<p>THIRD ANGLE PROJECTION</p>	<p>UNLESS OTHERWISE NOTED ALL DIMENSIONS ARE IN INCHES METRIC UNITS ARE DISPLAYED BENEATH IN [MM.]</p>		
	<p>PROPRIETARY AND CONFIDENTIAL THE INFORMATION CONTAINED IN THIS DRAWING IS THE SOLE PROPERTY OF BRAH ELECTRIC. ANY REPRODUCTION IN PART OR AS A WHOLE WITHOUT THE WRITTEN PERMISSION OF BRAH ELECTRIC IS PROHIBITED.</p>		<p>MATERIAL MOLDED PLASTIC CASE</p>
<p>FINISH N/A</p>	<p>DO NOT SCALE DRAWING</p>	<p>SIZE A DWG. NO. BLP1D8010BD REV. A</p>	
<p>SCALE: 1:5</p>		<p>WEIGHT: 3.2 LBS</p>	<p>SHEET 1 OF 1</p>