

PRODUCT CUT SHEET



BOSSTABKIT2: BRAH Electric, aftermarket direct replacement stabs for BOS Style bus plugs rated up to 200A @ 600V. Kit comes complete with a set of three stabs for A, B and C phases. Includes stab cover and mounting screw.

PRODUCT SPECIFICATIONS

Stab Kit
 PART NO. BOSSTABKIT2

<i>TYPE</i>	<i>VALUE (UNITS)</i>	<i>NOTES</i>	<i>COMMENTS</i>
<i>Bus Plug Replacements</i>	BOS & BD		
<i>Stab Material</i>	Copper	Silver Plated	
<i>VOLTAGE</i>	600 V		
<i>AMPERAGE</i>	200 A		

ADDITIONAL INFORMATION:

- * Stabs are supported with a spring assist to ensure sufficient contact on to the busbar
- * We use fine quality T2 copper and silver for manufacturing our stab assemblies.
- * Mounting hardware is not included

Warranty: All Products sold by BRAH Electric are guaranteed to be free of defect for a period of 2 years, under the condition that the product has been installed and operated properly. All items proven defective within the one year period will be replaced by BRAH Electric. In the event that we cannot provide a direct replacement, your monies will be refunded in full. We are not responsible for any consequential losses or damages outside of the defective product as well as any replacements or repairs performed by another party without our written authorization from BRAH Electric.

REVISIONS

ZONE	REV.	DESCRIPTION	DATE	APPROVED
------	------	-------------	------	----------

A PHASE

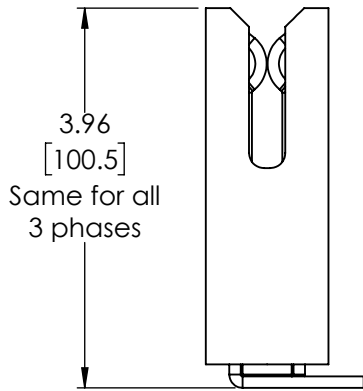

B PHASE

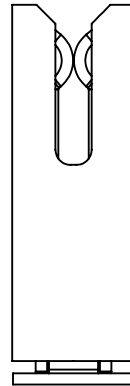

C PHASE

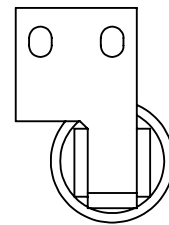
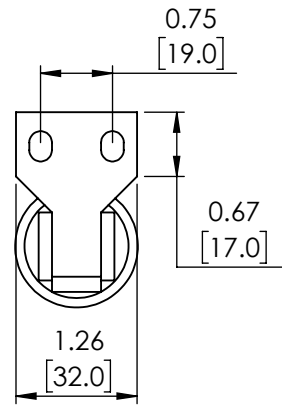
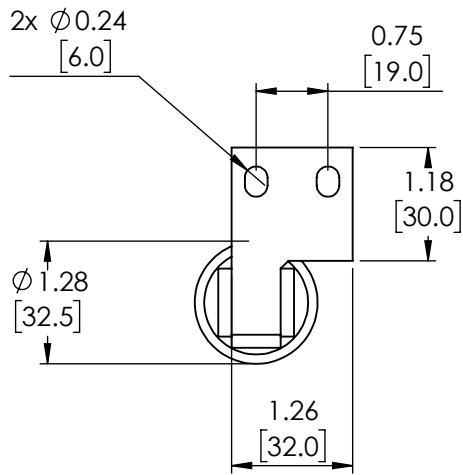
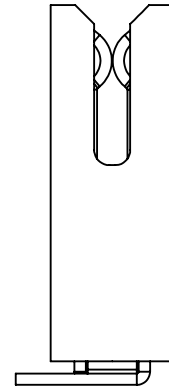

Dimensions same as A PHASE

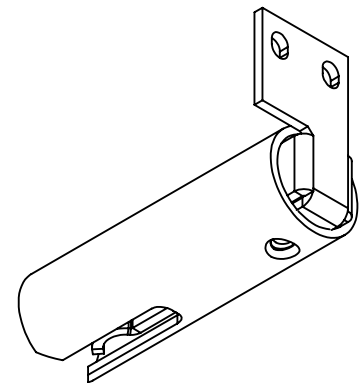
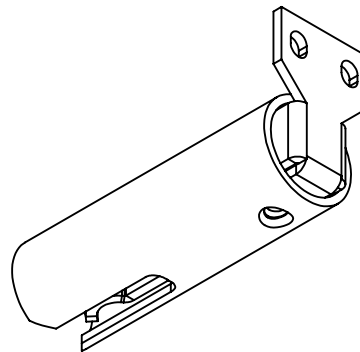
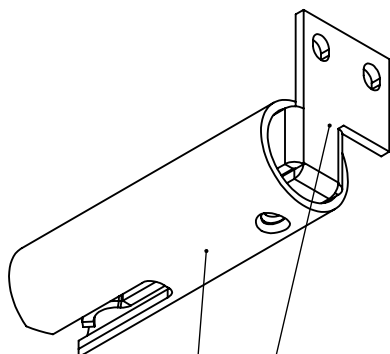

WWW.BRAHELECTRIC.COM, 855-355-2724

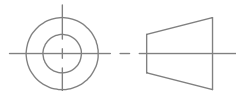

THIRD ANGLE PROJECTION

PROPRIETARY AND CONFIDENTIAL

THE INFORMATION CONTAINED IN THIS DRAWING IS THE SOLE PROPERTY OF BRAH ELECTRIC. ANY REPRODUCTION IN PART OR AS A WHOLE WITHOUT THE WRITTEN PERMISSION OF BRAH ELECTRIC IS PROHIBITED.

UNLESS OTHERWISE NOTED

ALL DIMENSIONS ARE IN INCHES
METRIC UNITS ARE DISPLAYED
BENEATH IN [MM.]

ERROR! ManufacturingApproval

MATERIAL
Copper with Silver Plating

FINISH
N/A

DO NOT SCALE DRAWING



BOSSTABKIT2

SIZE DWG. NO.

A

REV.

A

SCALE:1:2

SHEET 1 OF 1