



CONTACT US @ 855-355-2724

E-Mail: Sales@brahelectric.com

www.Brahelectric.com

PRODUCT DATA SHEET



Bus Plugs

Picture is for reference only,
Actual Kit may vary slightly

PART NUMBER – BUV3610GN:

BRAH Electric aftermarket UV463G, 100 amp, 600 volt, 3 phase, 4 wire, with ground, fusible style bus plug, type BUV / UV, suitable for use with OEM ITE / Siemens XL-U Series industrial busway systems, accepts Class R, H and K fuse types, direct substitute, fit and function for ITE OEM UV463G



PRODUCT SPECIFICATIONS

Manufacturer	BRAH Electric
Sub-Category	Fusible
Family	XL-U
Type	UV, BUV
Wire	4
Voltage	600
Amperage	100
A/C Rating	150ka@480V
Phase	3

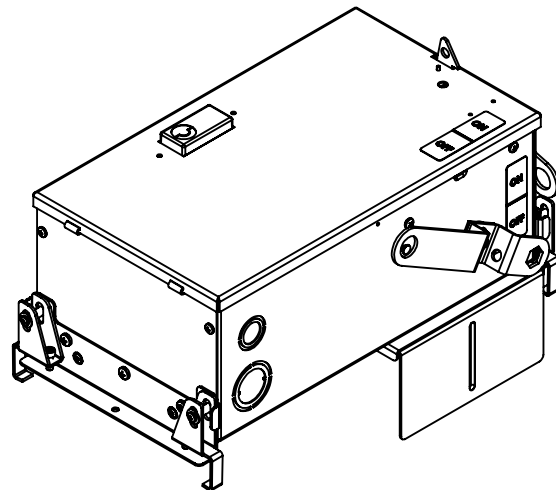
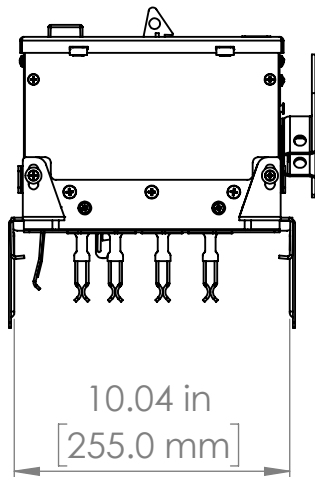
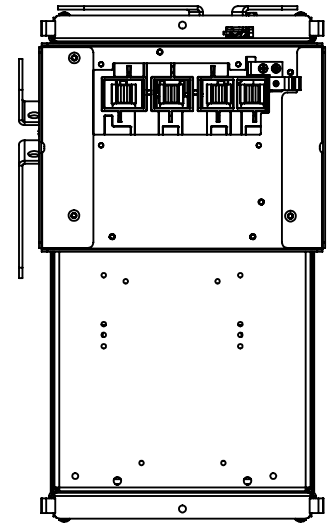
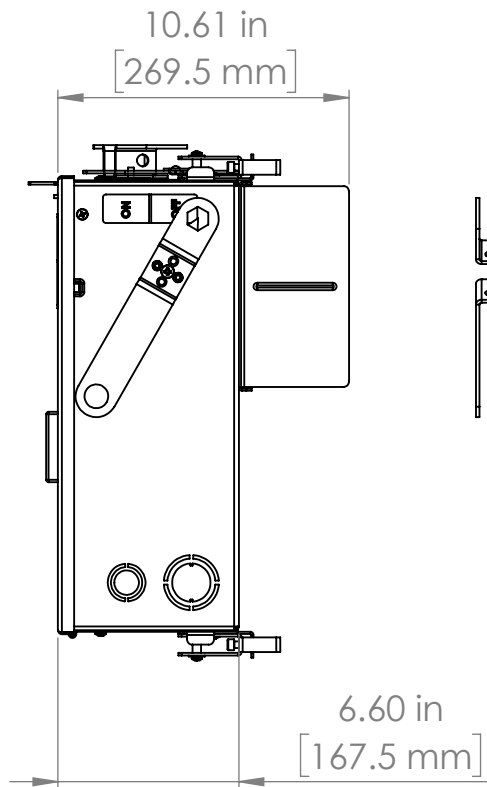
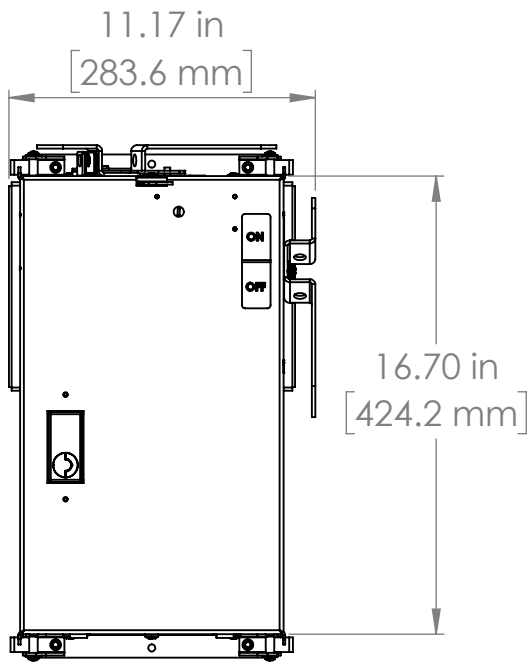
Warranty: All Products sold by BRAH Electric are guaranteed to be free of defect for a period of two years, under the condition that the product has been installed and operated properly. All items proven defective within the one year period will be replaced by BRAH Electric. In the event that we cannot provide a direct replacement, your monies will be refunded in full. We are not responsible for any consequential losses or damages outside of the defective product as well as any replacements or repairs performed by another party without our written authorization from BRAH Electric.

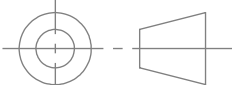

* NOTE: BRAH Electric aftermarketdirect UV463G, 100amp, 600volt, 3 phase, 4 wire, fusible style bus plug, type BUV / UV, Suitable for use with OEM ITE/ Siemens XL-U series industrial Busway System.

 THIRD ANGLE PROJECTION	UNLESS OTHERWISE NOTED ALL DIMENSIONS ARE IN INCHES METRIC UNITS ARE DISPLAYED BENEATH IN [MM.]				
	PROPRIETARY AND CONFIDENTIAL THE INFORMATION CONTAINED IN THIS DRAWING IS THE SOLE PROPERTY OF BRAH ELECTRIC. ANY REPRODUCTION IN PART OR AS A WHOLE WITHOUT THE WRITTEN PERMISSION OF BRAH ELECTRIC IS PROHIBITED.				FUSIBLE BUS BLUGS
	MATERIAL		SIZE A	DWG. NO. BUV3610GN	REV. A
	FINISH	N/A	SCALE:1:10	WEIGHT:	SHEET 1 OF 1
	DO NOT SCALE DRAWING				