



CONTACT US @ 855-355-2724

E-Mail: [Sales@brahelectric.com](mailto:Sales@brahelectric.com)

[www.Brahelectric.com](http://www.Brahelectric.com)

## PRODUCT DATA SHEET

---



**PART NUMBER – GE100AG:** BRAH Electric, aftermarket direct replacement bus plug parts, ground bar for General Electric Armor Clad ground kit assemblies, suitable for use with type AC bus plugs rated from 30A-100A; Armor Clad busway systems

### **PRODUCT SPECIFICATIONS**

Manufacturer	BRAH Electric
Sub-Category	Bus Plug Parts
Family	BRAH-Bus Plugs
Type	GE
Group	Bus Plug Parts
Type	For AC
Amperage Min	30A
Amperage Max	100A

Bus Plug Accessories  
PART NO. GE100AG

**Warranty:** All Products sold by BRAH Electric are guaranteed to be free of defect for a period of one year, under the condition that the product has been installed and operated properly. All items proven defective within the one year period will be replaced by BRAH Electric. In the event that we cannot provide a direct replacement, your monies will be refunded in full. We are not responsible for any consequential losses or damages outside of the defective product as well as any replacements or repairs performed by another party without our written authorization from BRAH Electric.

REVISIONS				
ZONE	REV.	DESCRIPTION	DATE	APPROVED

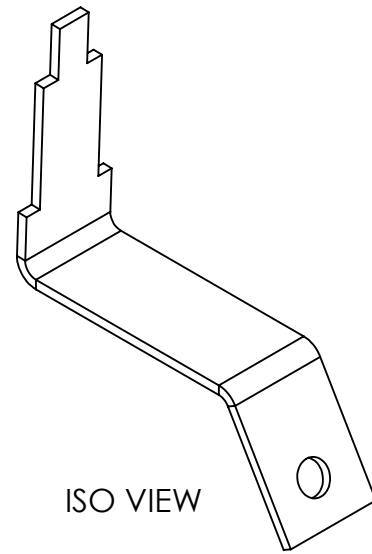

ISO VIEW

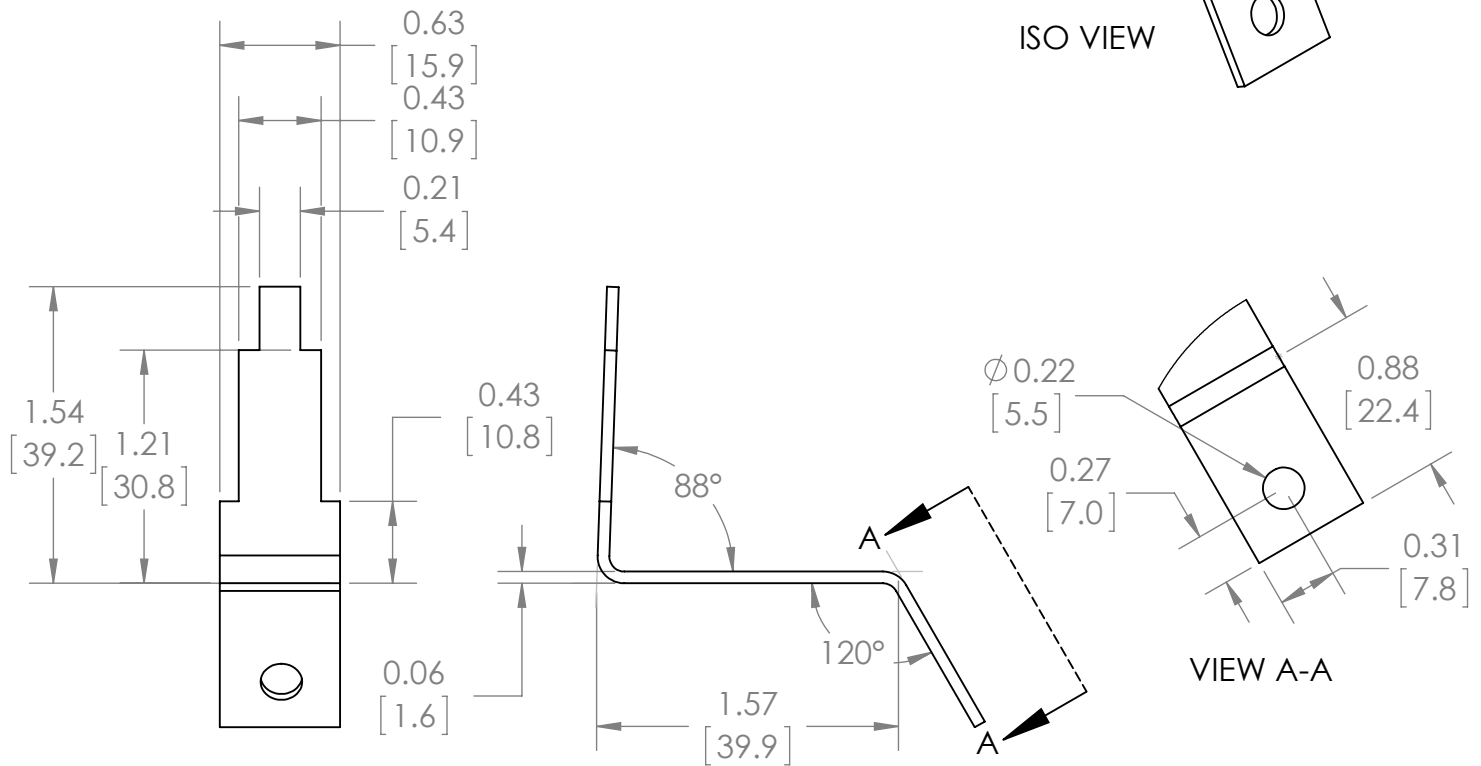

[WWW.BRAHELECTRIC.COM](http://WWW.BRAHELECTRIC.COM), 855-355-2724

\*NOTE: BRAH ELECTRIC BUS PLUG ACCESSORIES GE100AG, SUITABLE FOR USE WITH TYPE AC BUS PLUGS RATED FROM 30A-100A; ARMOR CLAD BUSWAY SYSTEMS

<p>THIRD ANGLE PROJECTION</p>	<p>UNLESS OTHERWISE NOTED</p> <p>ALL DIMENSIONS ARE IN INCHES METRIC UNITS ARE DISPLAYED BENEATH IN [ MM. ]</p>		
	<p><b>PROPRIETARY AND CONFIDENTIAL</b></p> <p>THE INFORMATION CONTAINED IN THIS DRAWING IS THE SOLE PROPERTY OF BRAH ELECTRIC. ANY REPRODUCTION IN PART OR AS A WHOLE WITHOUT THE WRITTEN PERMISSION OF BRAH ELECTRIC IS PROHIBITED.</p>	<p>MATERIAL -</p> <p>FINISH N/A</p> <p>DO NOT SCALE DRAWING</p>	<p><b>BUS PLUG ACCESSORIES</b></p> <p>SIZE <b>A</b> DWG. NO. <b>GE100AG</b> REV. <b>A</b></p> <p>SCALE: 1:1 WEIGHT: 3.2 LBS SHEET 1 OF 1</p>