



CONTACT US @ 855-355-2724  
E-Mail: [Sales@brahelectric.com](mailto:Sales@brahelectric.com)  
[www.Brahelectric.com](http://www.Brahelectric.com)

## PRODUCT DATA SHEET

---



**PART NUMBER – GEBPHANDLE1:** BRAH Electric, bus plug operating handle, for 30 amp, 60 amp, 100 amp and 200 amp can sizes, suitable for all Brahelectric bus plug substitute models as well as the respective OEM General Electric models, including SB, SL, AC, FVK, DE and DH models.

### **PRODUCT SPECIFICATIONS**

Bus Plug Accessories  
PART NO. GEBPHANDLE2

Manufacturer	BRAH Electric
Sub-Category	BUS Plug Parts
Family	BRAH-Bus Plugs
Type	GEBP
Group	Operating Handles
Type For	AC, SB, SL, FVK, DE & DH
AMPERAGE MIN	30A
AMPERAGE MAX	200A

**Warranty:** All Products sold by BRAH Electric are guaranteed to be free of defect for a period of one year, under the condition that the product has been installed and operated properly. All items proven defective within the one year period will be replaced by BRAH Electric. In the event that we cannot provide a direct replacement, your monies will be refunded in full. We are not responsible for any consequential losses or damages outside of the defective product as well as any replacements or repairs performed by another party without our written authorization from BRAH Electric.

REVISIONS				
ZONE	REV.	DESCRIPTION	DATE	APPROVED

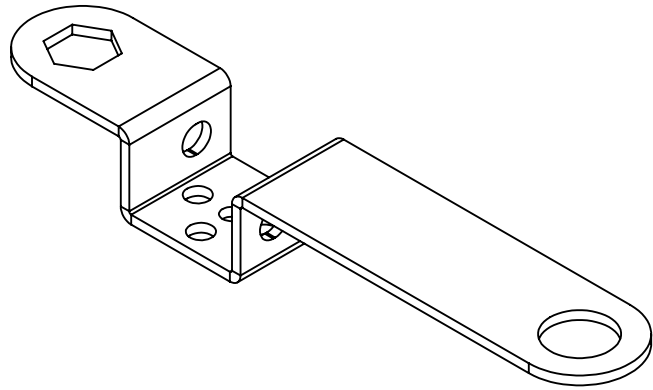

ISO VIEW

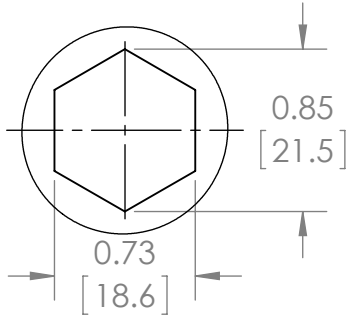

DETAIL A  
SCALE 1:1

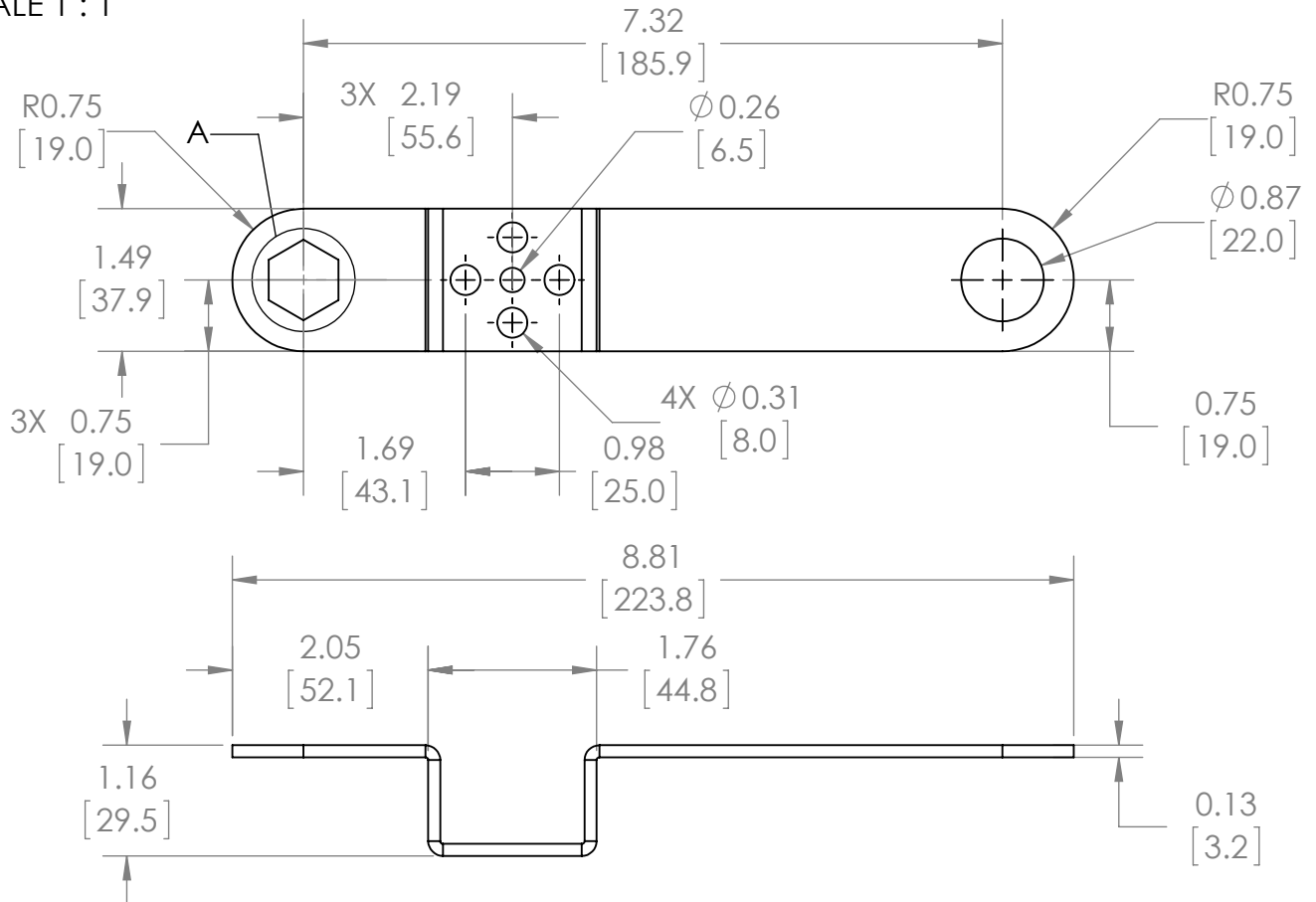

[WWW.BRAHELECTRIC.COM](http://WWW.BRAHELECTRIC.COM), 855-355-2724

\*NOTE: BRAH ELECTRIC BUS PLUG ACCESSORIES GEBPHANDLE IS AN AFTERMARKET DIRECT REPLACEMENT SUITABLE FOR USE WITH AC, SB, SL, FVK BREAKERTYPE AND FUSIBLE BUS PLUGS

THIRD ANGLE PROJECTION

**PROPRIETARY AND CONFIDENTIAL**

THE INFORMATION CONTAINED IN THIS DRAWING IS THE SOLE PROPERTY OF BRAH ELECTRIC. ANY REPRODUCTION IN PART OR AS A WHOLE WITHOUT THE WRITTEN PERMISSION OF BRAH ELECTRIC IS PROHIBITED.

UNLESS OTHERWISE NOTED  
ALL DIMENSIONS ARE IN INCHES  
METRIC UNITS ARE DISPLAYED  
BENEATH IN [ MM. ]

MATERIAL	-
FINISH	N/A
DO NOT SCALE DRAWING	



**BUS PLUG ACCESSORIES**

SIZE	DWG. NO.	REV.
<b>A</b>	<b>GEBPHANDLE 1</b>	<b>A</b>
SCALE: 1:4	WEIGHT: 3.2 LBS	SHEET 1 OF 1