



CONTACT US

855.355.2724

E-Mail: sales@brahelectric.com

www.brahelectric.com

PRODUCT DATA SHEET



PART NUMBER – MCCSTABS-CH-F2100-250A

MCCSTABS-CH-F2100-250A, type F2100, motor control part, mcc stab assemblies, rated for 250A 600VAC service, complete with cable connectors, suitable for use with F2100, Five Star, 2100 & Advantage series MCC buckets and motor control centers

MCC PARTS

PART NO. MCCSTABS-CH-F2100-250A

PRODUCT SPECIFICATIONS

Manufacturer	BRAH Electric
Sub-Category	Stab Kits
Family	Five Star
Type	F2100
OEM Manufacturer	Cutler Hammer
OEM Part No.	4700A97G69
Amperage Max	250A

Warranty: All Products sold by BRAH Electric are guaranteed to be free of defect for a period of two years, under the condition that the product has been installed and operated properly. All items proven defective within the one year period will be replaced by BRAH Electric. In the event that we cannot provide a direct replacement, your monies will be refunded in full. We are not responsible for any consequential losses or damages outside of the defective product as well as any replacements or repairs performed by another party without our written authorization from BRAH Electric.

4

3

2

1

REVISIONS				
ZONE	REV.	DESCRIPTION	DATE	APPROVED

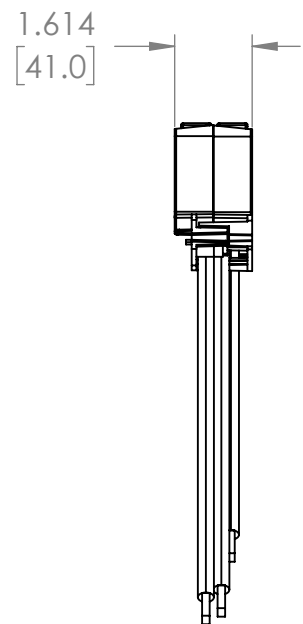
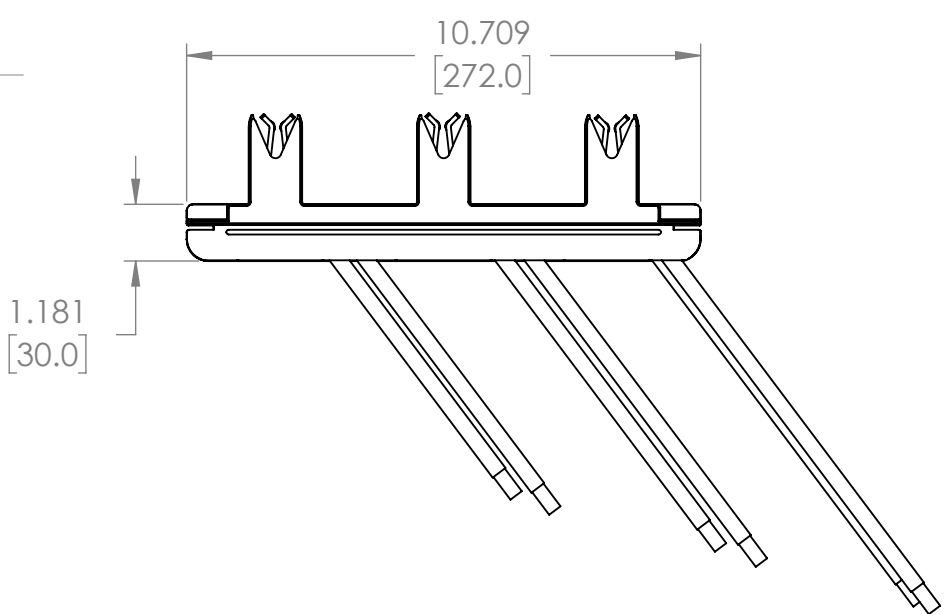
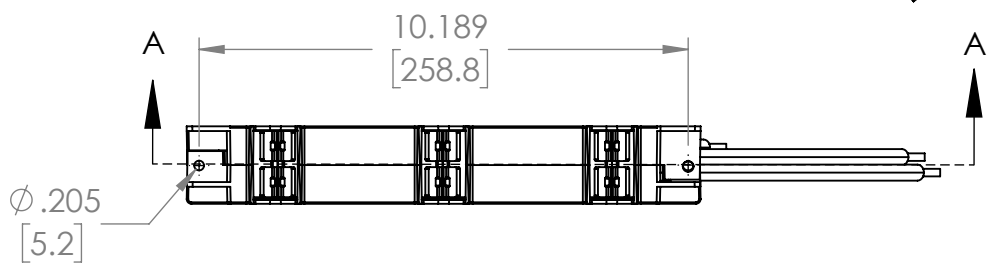
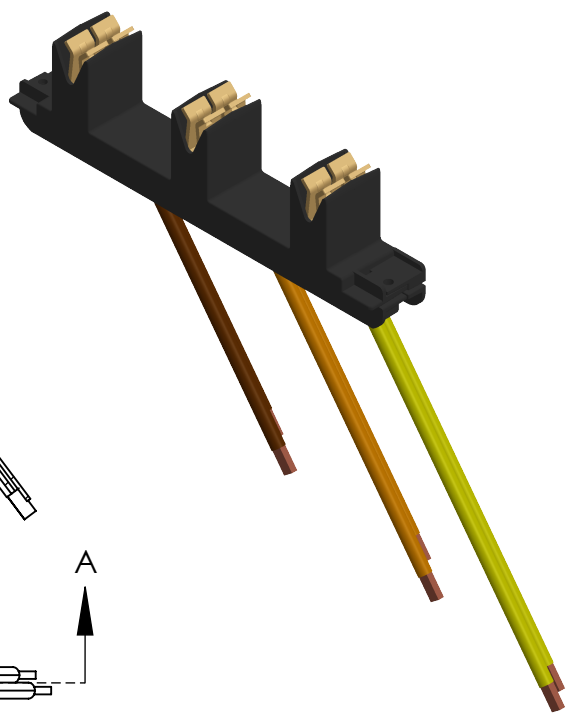
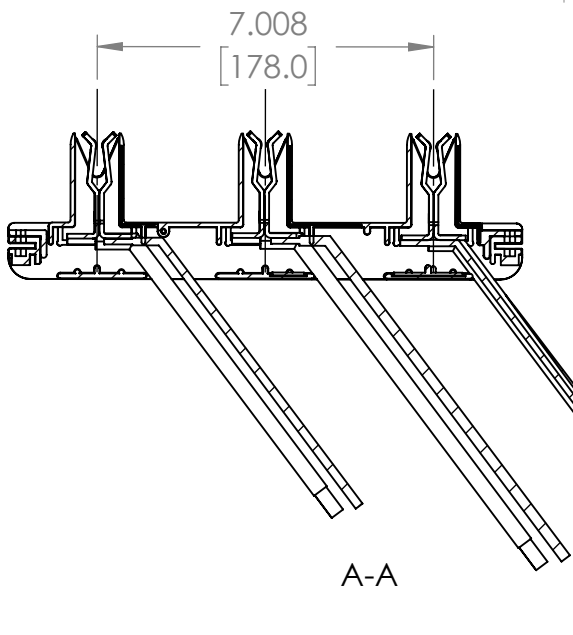

WWW.BRAHELECTRIC.COM, 855-355-2724

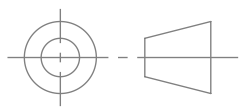

THIRD ANGLE PROJECTION

UNLESS OTHERWISE NOTED
ALL DIMENSIONS ARE IN INCHES
METRIC UNITS ARE DISPLAYED
BENEATH IN [MM.]

GENERAL TOLERANCE
ASME Y14.5M-1994

MATERIAL
Copper with Silver Plating

FINISH
N/A

DRAWN
MHENRY

DATE
3/15/2024



MCC Stab Assembly

PROPRIETARY AND CONFIDENTIAL
THE INFORMATION CONTAINED IN THIS
DRAWING IS THE SOLE PROPERTY OF
BRAH ELECTRIC. ANY REPRODUCTION
IN PART OR AS A WHOLE WITHOUT THE
WRITTEN PERMISSION OF BRAH ELECTRIC
IS PROHIBITED.

DO NOT SCALE DRAWING

SIZE	DWG. NO.	REV.
A	F2100 250A	A

SCALE:1:4 WEIGHT: 3.2 LBS SHEET 1 OF 1

4

3

2

1