



CONTACT US @ 855-355-2724

E-Mail: Sales@brahelectric.com

www.Brahelectric.com

PRODUCT DATA SHEET

PART NUMBER- RV 200G:

BRAH Electric, XL-U, Ground kit, type RV, rated for 200Amp & 600Volt maximum, suitable for use with RV series bus plugs and busway systems.



Ground Kits

Picture is for reference only,
Actual Kit may vary slightly

PRODUCT SPECIFICATIONS

Manufacturer	BRAH Electric
Sub-Category	Ground Kit
Family	XL-U
Type	RV
Voltage	600
Amperage	200
Suitable for	RV

Warranty: All Products sold by BRAH Electric are guaranteed to be free of defect for a period of two years, under the condition that the product has been installed and operated properly. All items proven defective within the one year period will be replaced by BRAH Electric. In the event that we cannot provide a direct replacement, your monies will be refunded in full. We are not responsible for any consequential losses or damages outside of the defective product as well as any replacements or repairs performed by another party without our written authorization from BRAH Electric.

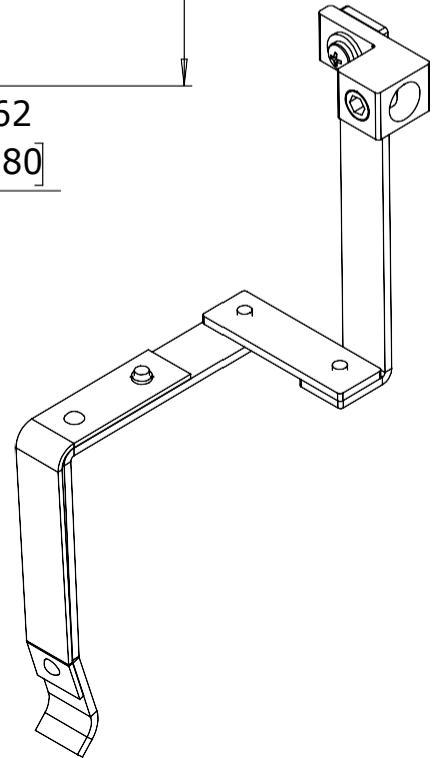
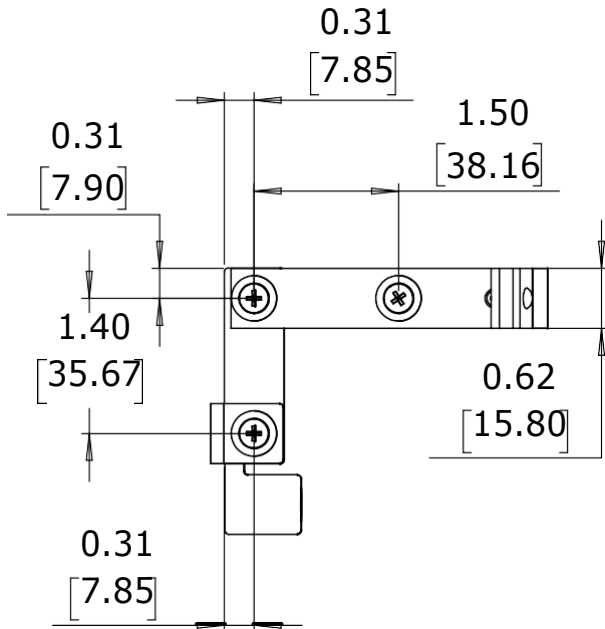
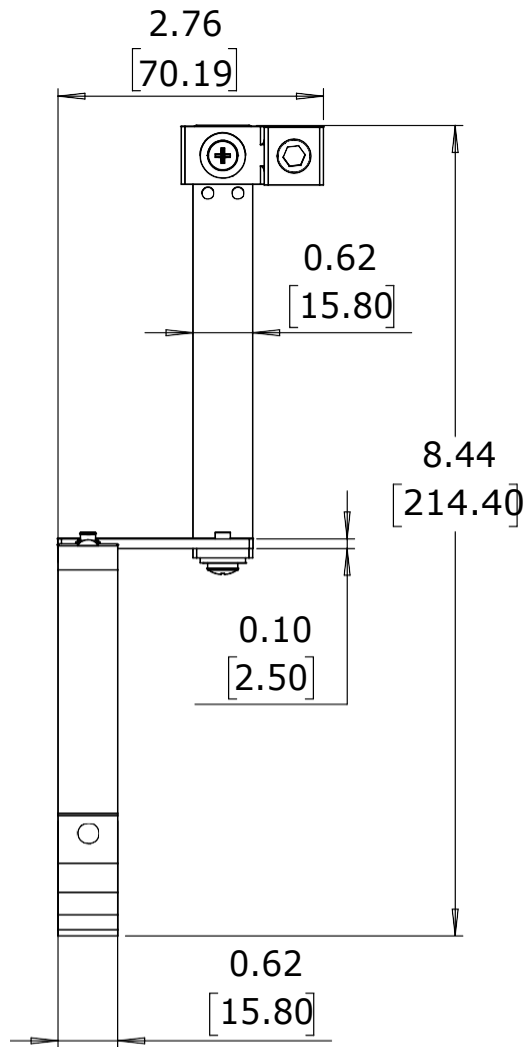
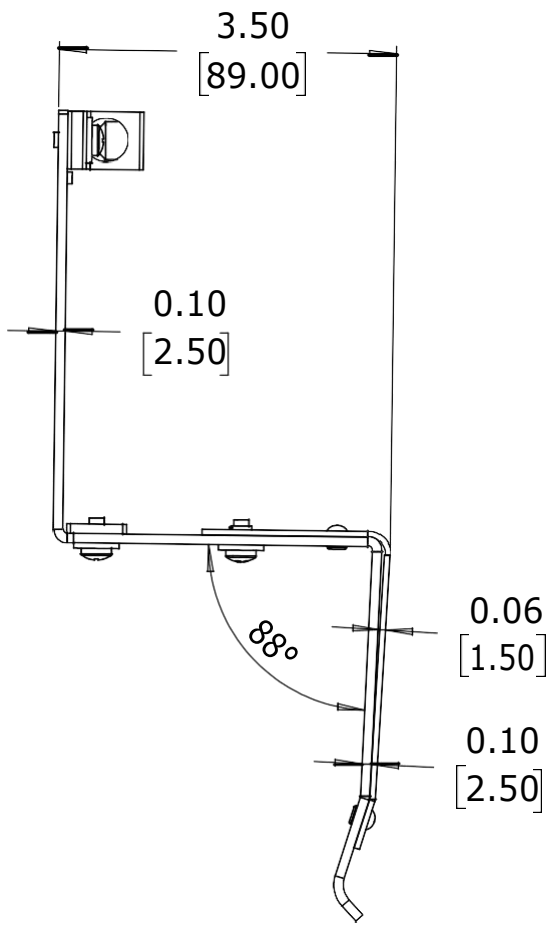

WWW.BRAHELECTRIC.COM , 855-355-2724

* NOTE: BRAH ELECTRIC, XL-U, GROUND KITS, TYPE RV, 200A, 600V, SUITABLE FOR USE WITH RV BUS PLUGS

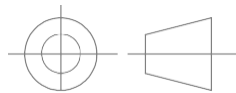

THIRD ANGLE PROJECTION

PROPRIETARY AND CONFIDENTIAL

THE INFORMATION CONTAINED IN THIS DRAWING IS THE SOLE PROPERTY OF BRAH ELECTRIC. ANY REPRODUCTION IN PART OR AS A WHOLE WITHOUT THE WRITTEN PERMISSION OF BRAH ELECTRIC IS PROHIBITED.

UNLESS OTHERWISE NOTED

ALL DIMENSIONS ARE IN INCHES
METRIC UNITS ARE DISPLAYED
BENEATH IN [MM.]

MATERIAL

FINISH

N/A

DO NOT SCALE DRAWING



Ground Kit

SIZE DWG. NO.

A

RV 200G

REV.

A

SCALE: 1:2

WEIGHT:

SHEET 1 OF 1