



CONTACT US

855.355.2724

E-Mail: sales@brahelectric.com

[www.brahelectric.com](http://www.brahelectric.com)

## PRODUCT DATA SHEET



STAB KITS

PART NO. UVSTABKIT1

### PART NUMBER – UVSTABKIT1

UVSTABKIT1, bus plug stab assembly kit, complete set of 3 stabs, assembly package includes stab fingers and associated stab insulators, direct fit and function with OEM ITE and Siemens XL-U Series bus plug type UV, can be used with all 3W or 4W applications within the Bulldog Series, rated for all 30 amp, 60 amp and 100 amp bus plug applications for both 240 volt and 600 volt systems, substitute kit for OEM Siemens, ITE, Gould XL-U Series bus plugs

### PRODUCT SPECIFICATIONS

Manufacturer	BRAH Electric
Sub-Category	Stab Kits
Family	XL-U Series
Type	UV, BUV
OEM Manufacturer	Siemens
Amperage	30A - 100A
Voltage	240V

**Warranty:** All Products sold by BRAH Electric are guaranteed to be free of defect for a period of two years, under the condition that the product has been installed and operated properly. All items proven defective within the one year period will be replaced by BRAH Electric. In the event that we cannot provide a direct replacement, your monies will be refunded in full. We are not responsible for any consequential losses or damages outside of the defective product as well as any replacements or repairs performed by another party without our written authorization from BRAH Electric.

8 7 6 5 4 3 2 1

REVISIONS				
ZONE	REV.	DESCRIPTION	DATE	APPROVED

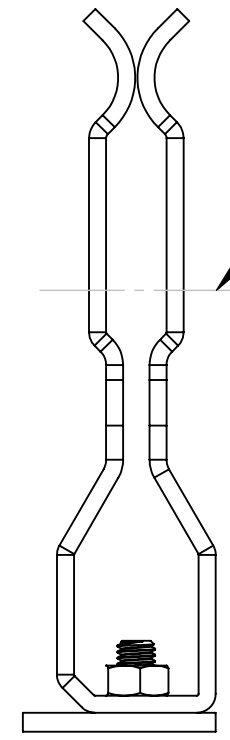
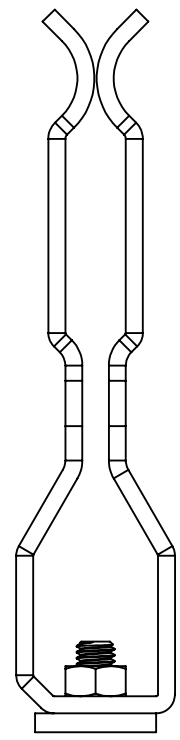
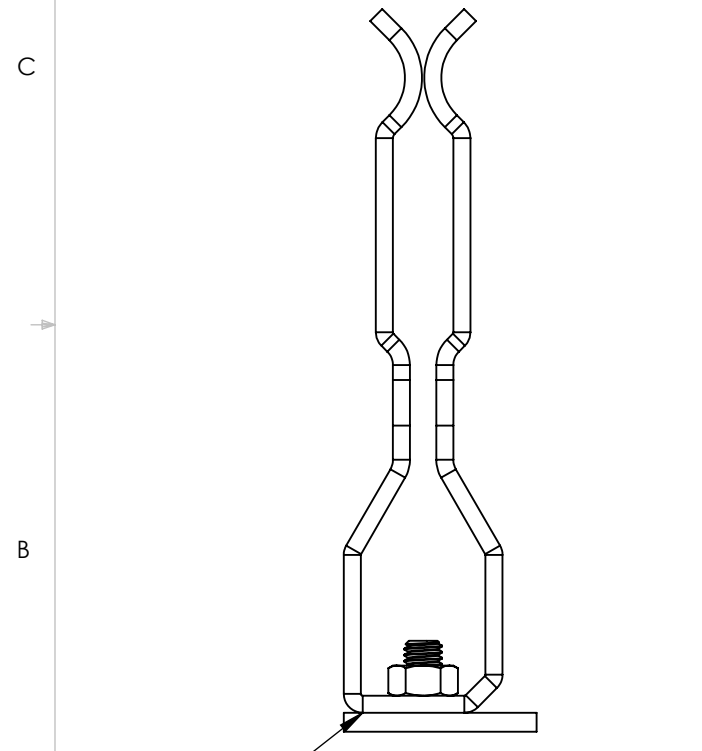
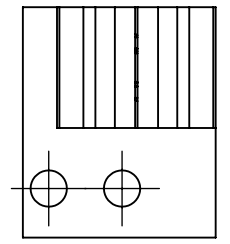
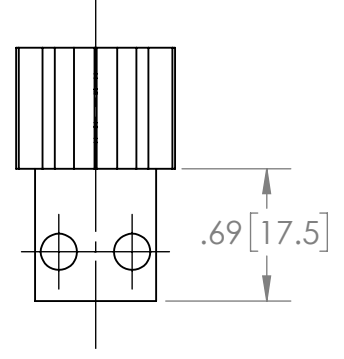
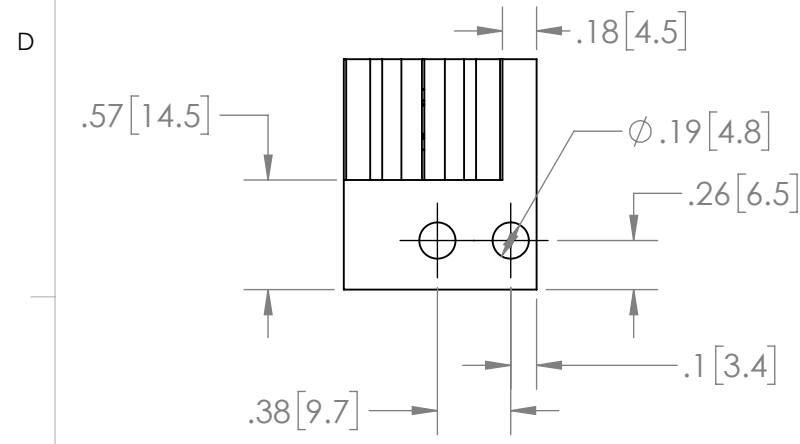

ADD HEAT SHRINK FROM BASE UP TO THIS MARK APPROX.

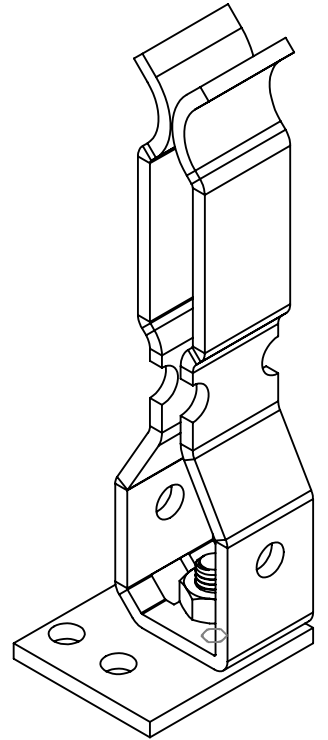

WELD/SOLDER AROUND COMPLETE PERIMETER OF STAB



<p>THIRD ANGLE PROJECTION</p>	<p>UNLESS OTHERWISE SPECIFIED:</p> <p>DIMENSIONS ARE IN MM</p> <p>TOLERANCES:</p> <p>ANGULAR: MACH ± .5 DEG.</p> <p>WHOLE NUMBER ± .5</p> <p>ONE PLACE DECIMAL ± .25</p> <p>TWO PLACE DECIMAL ± .13</p>	<table border="1"> <tr> <td>NAME</td> <td>DATE</td> </tr> <tr> <td>G.GARCIA</td> <td>10-15-13</td> </tr> </table>	NAME	DATE	G.GARCIA	10-15-13	<p><b>BRAH Electric, LLC</b></p>							
	NAME	DATE												
G.GARCIA	10-15-13													
<p>PROPRIETARY AND CONFIDENTIAL</p> <p>THE INFORMATION CONTAINED IN THIS DRAWING IS THE SOLE PROPERTY OF BRAH ELECTRIC, LLC. ANY REPRODUCTION IN PART OR AS A WHOLE WITHOUT THE WRITTEN PERMISSION OF BRAH ELECTRIC, LLC IS PROHIBITED.</p>	<p>INTERPRET GEOMETRIC TOLERANCING PER: ASME Y14.5M-1994 MATERIAL</p>	<table border="1"> <tr> <td>DRAWN</td> <td> </td> </tr> <tr> <td>CHECKED</td> <td> </td> </tr> <tr> <td>ENG APPR.</td> <td> </td> </tr> <tr> <td>MFG APPR.</td> <td> </td> </tr> <tr> <td>Q.A.</td> <td> </td> </tr> </table>	DRAWN		CHECKED		ENG APPR.		MFG APPR.		Q.A.		<p>TITLE:</p> <p><b>UVSTABKIT1</b></p>	
DRAWN														
CHECKED														
ENG APPR.														
MFG APPR.														
Q.A.														
<p>FINISH</p> <p>DO NOT SCALE DRAWING</p>	<p>COMMENTS:</p> <p>UNLESS OTHERWISE NOTED</p> <p>ALL DIMENSIONS ARE IN INCHES</p> <p>METRIC UNITS ARE DISPLAYED BENEATH IN [ MM. ]</p>	<table border="1"> <tr> <td>SIZE</td> <td>DWG. NO.</td> <td>REV</td> </tr> <tr> <td><b>B</b></td> <td> </td> <td><b>A</b></td> </tr> </table>	SIZE	DWG. NO.	REV	<b>B</b>		<b>A</b>	<p>SCALE: 1:1 WEIGHT: 65.960 SHEET 1 OF 2</p>					
SIZE	DWG. NO.	REV												
<b>B</b>		<b>A</b>												

8 7 6 5 4 3 2 1