



CONTACT US

855.355.2724

E-Mail: sales@brahelectric.com

www.brahelectric.com

PRODUCT DATA SHEET



PART NUMBER – BE-SRPE30A30

BE-SRPE30A30, 30A rating plug, type SRPE for use with 30A CT sensor rating. Direct substitute for General Electric Spectra Series interchangeable rating plug element SRPE30A30. Suitable for use with Spectra RMS trip devices. Compatible with SEDA, SEHA, SELA, SEPA circuit breaker frame types.

RATING PLUGS

PART NO. BE-SRPE30A30

RATING PLUG INST. ADJUST RANGE

LOW – 87A	237A
112A	314A
142A	HI – 415A
179A	

PRODUCT SPECIFICATIONS

Manufacturer	BRAH Electric
Sub-Category	Rating Plugs
Family	Spectra Series
Type	SRPE
For Frame Size	SEDA, SEHA, SELA, SEPA
OEM Manufacturer	General Electric
OEM Part No.	SRPE30A30
Amperage Max	30
Trip Type	Spectra RMS
SAmp	30
PAmp	30

Warranty: All Products sold by BRAH Electric are guaranteed to be free of defect for a period of two years, under the condition that the product has been installed and operated properly. All items proven defective within the one year period will be replaced by BRAH Electric. In the event that we cannot provide a direct replacement, your monies will be refunded in full. We are not responsible for any consequential losses or damages outside of the defective product as well as any replacements or repairs performed by another party without our written authorization from BRAH Electric.

REVISIONS				
ZONE	REV.	DESCRIPTION	DATE	APPROVED

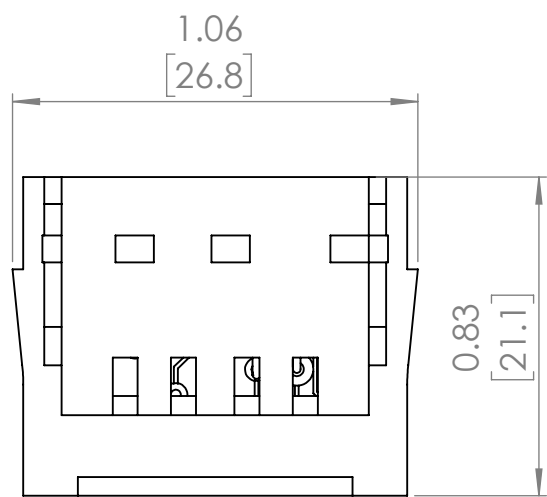
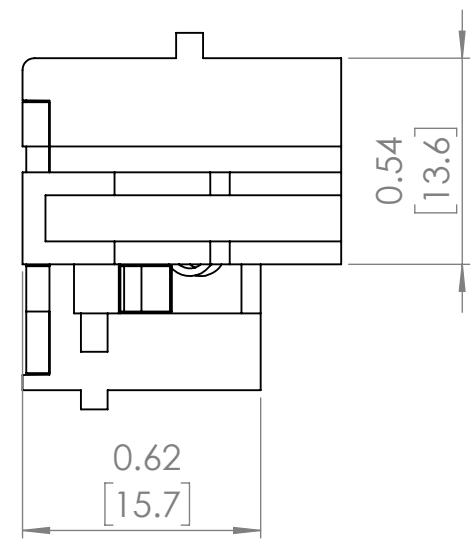
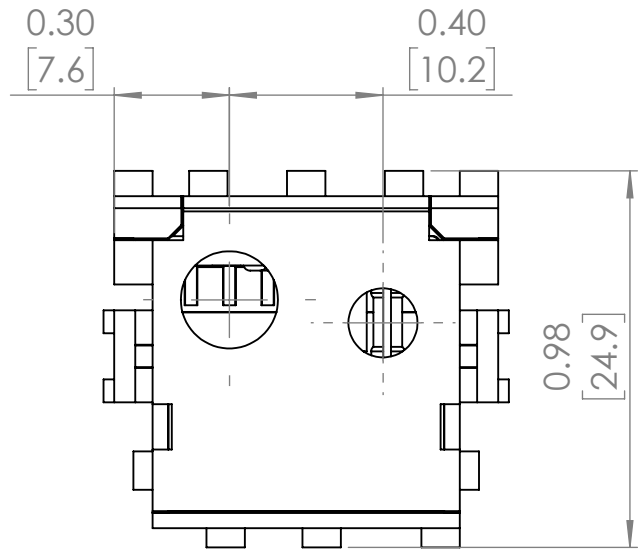
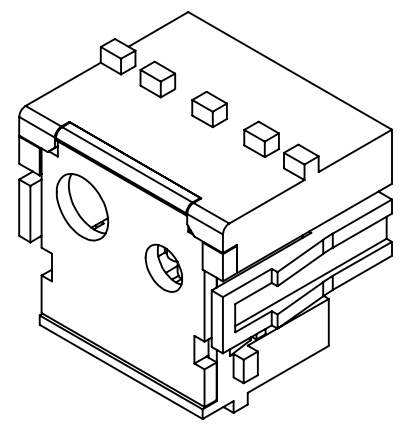

WWW.BRAHELECTRIC.COM, 855-355-2724

Drawing diagrams are for reference only.

Actual Kit may vary slightly

<p>THIRD ANGLE PROJECTION</p>	<p>UNLESS OTHERWISE NOTED</p> <p>ALL DIMENSIONS ARE IN INCHES</p> <p>METRIC UNITS ARE DISPLAYED</p> <p>BENEATH IN [MM.]</p>			
	<p>PROPRIETARY AND CONFIDENTIAL</p> <p>THE INFORMATION CONTAINED IN THIS DRAWING IS THE SOLE PROPERTY OF BRAH ELECTRIC. ANY REPRODUCTION IN PART OR AS A WHOLE WITHOUT THE WRITTEN PERMISSION OF BRAH ELECTRIC IS PROHIBITED.</p>			<p>MATERIAL</p> <p>FINISH</p> <p>DO NOT SCALE DRAWING</p>
<p>SIZE A DWG. NO. BE-SRPE30A30 REV. A</p>		<p>SCALE: 2:1</p>	<p>WEIGHT: 3.2 LBS</p>	<p>SHEET 1 OF 1</p>