



CONTACT US

855.355.2724

E-Mail: sales@brahelectric.com

www.brahelectric.com

PRODUCT DATA SHEET

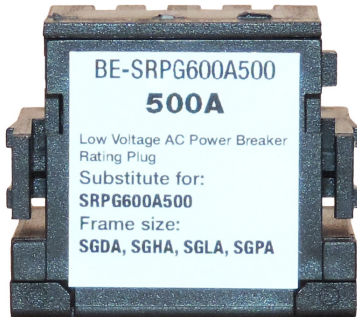

PART NUMBER – BE-SRPG600A500

BE-SRPG600A500, 500A rating plug, type SRPG for use with 600A CT sensor rating. Direct substitute for General Electric Spectra Series interchangeable rating plug element SRPG600A500. Suitable for use with Spectra RMS trip devices. Compatible with SGDA, SGHA, SGLA, SGPA circuit breaker frame types.

RATING PLUGS

PART NO. BE-SRPG600A500

RATING PLUG INST. ADJUST RANGE

LOW – 1525A	2995A
1925A	3920A
2425A	HI – 5060A

PRODUCT SPECIFICATIONS

Manufacturer	BRAH Electric
Sub-Category	Rating Plugs
Family	Spectra Series
Type	SRPG
For Frame Size	SGDA, SGHA, SGLA, SGPA
OEM Manufacturer	General Electric
OEM Part No.	SRPG600A500
Amperage Max	500
Trip Type	Spectra RMS
SAmp	600
PAmp	500

Warranty: All Products sold by BRAH Electric are guaranteed to be free of defect for a period of two years, under the condition that the product has been installed and operated properly. All items proven defective within the one year period will be replaced by BRAH Electric. In the event that we cannot provide a direct replacement, your monies will be refunded in full. We are not responsible for any consequential losses or damages outside of the defective product as well as any replacements or repairs performed by another party without our written authorization from BRAH Electric.

REVISIONS				
ZONE	REV.	DESCRIPTION	DATE	APPROVED

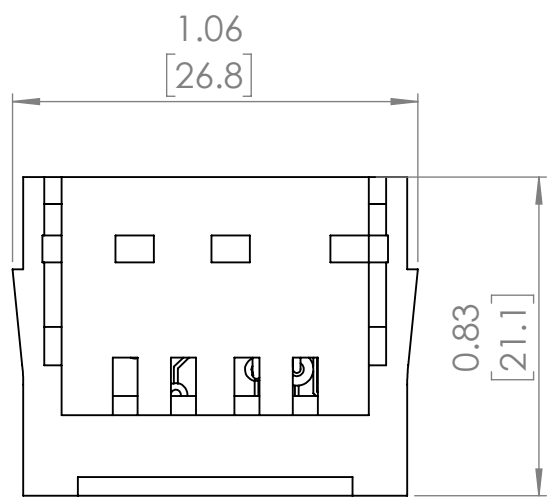
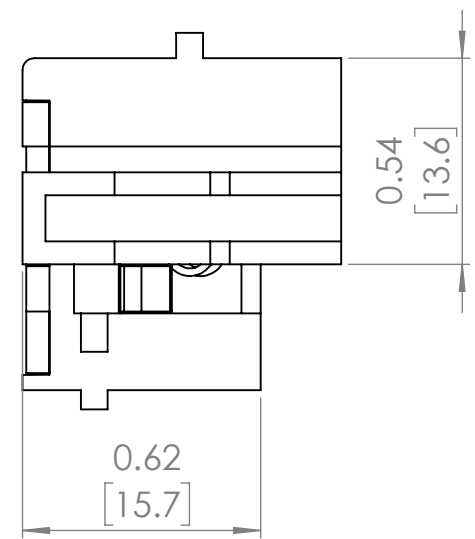
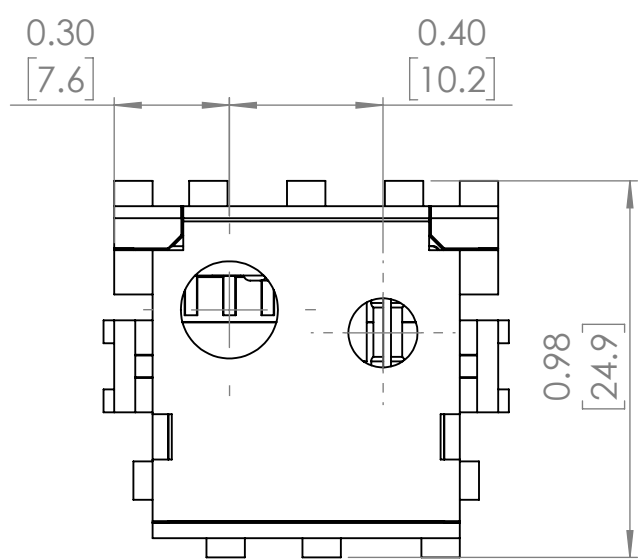
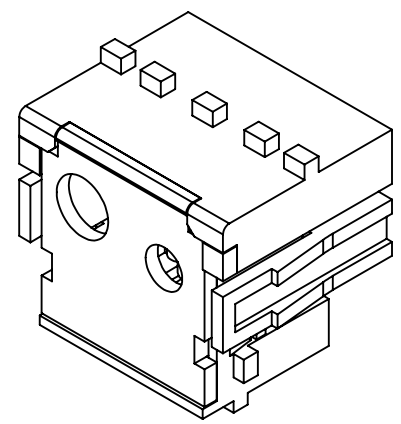

WWW.BRAHELECTRIC.COM, 855-355-2724

Drawing diagrams are for reference only.

Actual Kit may vary slightly

<p>THIRD ANGLE PROJECTION</p>	<p>UNLESS OTHERWISE NOTED ALL DIMENSIONS ARE IN INCHES METRIC UNITS ARE DISPLAYED BENEATH IN [MM.]</p>			
	<p>PROPRIETARY AND CONFIDENTIAL THE INFORMATION CONTAINED IN THIS DRAWING IS THE SOLE PROPERTY OF BRAH ELECTRIC. ANY REPRODUCTION IN PART OR AS A WHOLE WITHOUT THE WRITTEN PERMISSION OF BRAH ELECTRIC IS PROHIBITED.</p>			<p>MATERIAL</p> <p>FINISH</p> <p>DO NOT SCALE DRAWING</p>
<p>SIZE A DWG. NO. BE-SRPG600A500 REV. A</p>		<p>SCALE: 2:1</p>	<p>WEIGHT: 3.2 LBS</p>	<p>SHEET 1 OF 1</p>