

LOGSET Harvester Head



TH65X

Versatile head for thinning and clear felling

The Logset TH65 is a versatile head built for thinning and final felling on all types of sites.

It is compact for early thinning operations, yet powerful enough to fell trees up to 65 cm. Optimal productivity is achieved with diameters up to 45 cm. The head is well matched with the Logset 8H GT harvester.

The Logset TH65 has all the power, yet is not heavy, which makes it perfect for longer cranes with a wider reach. Many options are available for different customer needs, such as alternative

feeding wheels, color marking and stump treatment.

Logset TH65X version has two feeding wheels and a support back roller instead of a feeding back roller. This construction leaves more space in the harvester head. The simple design makes it ideal for excavators and other base machines with lower capacity.

SIMPLY BETTER

LOGSET

LOGSET Harvester Head TH65 / TH65X

TH65

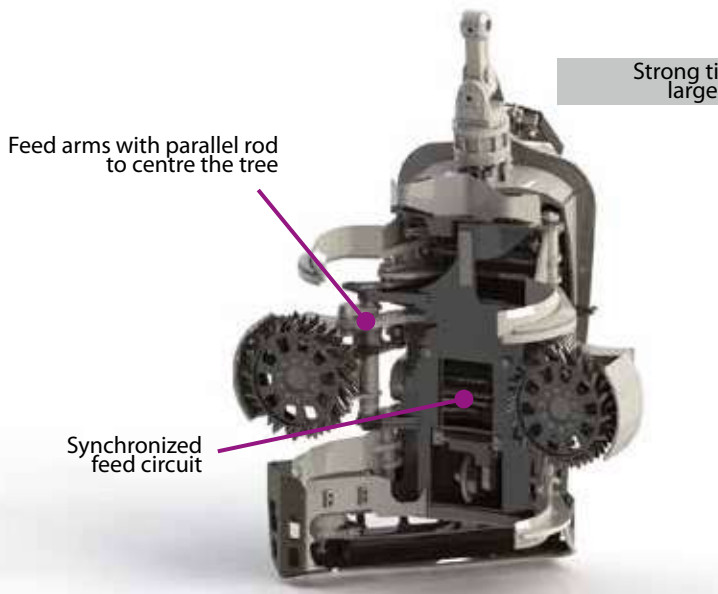

TH65X

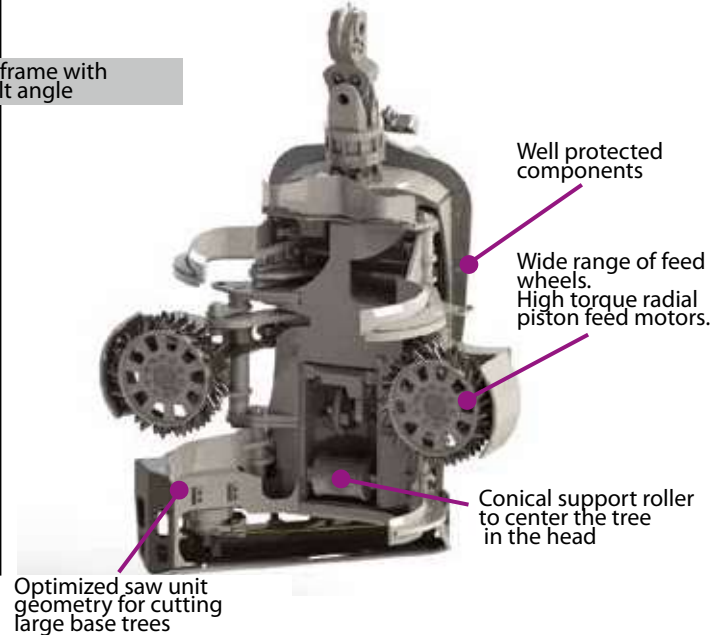

Technical data

DIMENSIONS		
Width, head open	mm	1560 (61 in)
Width, head closed	mm	1200 (47 in)
Height to top knife	mm	1380 (54 in)
Height with rotator and link	mm	1900 (75 in)
Weight with rotator and link	kg	1150 (2 530 lbs)
FELLING/CUTTING		
Max. felling/cutting diameter	mm	720 (28 in)
Saw bar	mm	820 (32 in)
Saw unit		SuperCut 100
Saw motor		Parker F11-19, Bucher 20/25
Saw chain tensioning		Hydraulic
Chain oil tank volume	liter	8 (2 gal)
HYDRAULIC SYSTEM		
Max. pressure	bar	280 (4 061 psi)
Flow required for optimal prod.	l/min	300 (79 gal/min)
Valve block: purpose built hydraulic manifold		
FEEDING		
Hydraulic motors, feeding arms	cm ³	620/820
Hydraulic motors, chassis	cm ³	315/400
Number of hydraulic motors	pcs	4 / 2 for X model
Feeding speed (300 l/min, 79 gal/min)	m/s	6,0/4,7 (20/15 ft/s)
Max. opening, feed wheels	mm	630 (25 in)

DELIMBING		
Max. opening, upper knives	mm	680 (27 in)
Delimiting diameter tip to tip	mm	450 (18 in)
Number of static knives	pcs	1
Number of movable knives	pcs	4
ROTATOR		
Indexator AV 12-17/H122-182, Black Bruin BBR 15-16		
MEASURING DEVICE		
Logset TOC-MD 2		
RECOMMENDED BASE MACHINE SIZE		
Wheeled base, from		14-18 t. (31 000-40 000 lbs)
Tracked base, from		16-20 t. (35 000-44 000 lbs)
OPTIONAL EQUIPMENT		
Contact your local dealer for more information about options.		

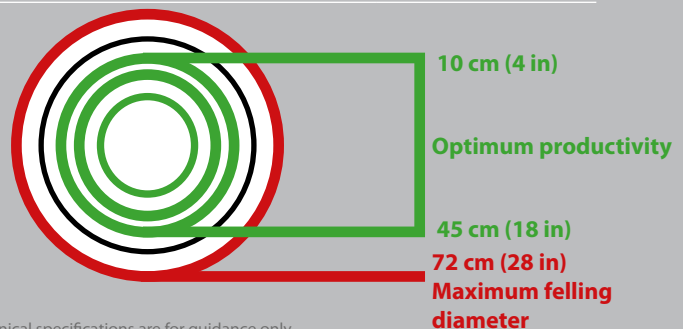

Harvester heads range 12/17 - EN. We reserve the right to make changes without prior notice. All technical specifications are for guidance only. The pictures and diagrams do not always show standard versions of the heads. Copyright Logset Oy.

Logset Oy
Hännisentie 2
FI-66530 Koivulahti
FINLAND
Tel. +358 10 286 3200

LOGSET
SIMPLY BETTER
www.logset.com