

NOZZLES

High Quality Jetting for pressures up to 40,000 psi/2800 bar

ATTACK TIPS

StoneAge Attack Tips are the highest quality, longest lasting nozzles available for low and medium pressure applications (up to 22k psi/1500 bar). Flow straighteners correct turbulence, ensuring excellent jetting results.

Stainless or carbide steel available.

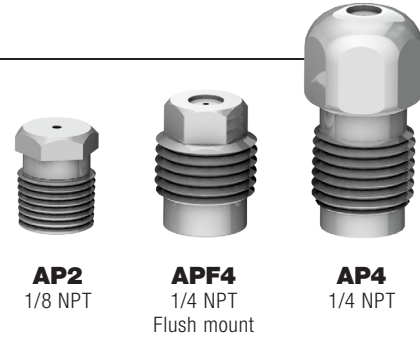

NOZZLE FLOW CHART

Nozzle Size		PRESSURE (PSI & BAR)															#									
		2,000 140		4,000 280		6,000 410		8,000 550		10,000 700		12,000 830		14,000 970		15,000 1000		16,000 1100		18,000 1200		20,000 1400		22,000 1500		
in.	mm																									
.018	0.46	0.4	2	0.6	2	0.7	3	0.8	3	0.9	3	1.0	4	1.0	4	1.1	4	1.1	4	1.2	5	1.2	5	1.3	5	0.6
.020	0.51	0.5	2	0.7	3	0.8	3	1.0	4	1.1	4	1.2	5	1.3	5	1.3	5	1.5	6	1.5	6	1.5	6	1.6	6	0.7
.022	0.56	0.6	2	0.8	3	1.0	4	1.2	5	1.3	5	1.4	5	1.5	6	1.6	6	1.6	6	1.7	6	1.8	7	1.9	7	0.8
.024	0.61	0.7	3	1.0	4	1.2	5	1.4	5	1.6	6	1.7	6	1.8	7	1.9	7	2.0	8	2.1	8	2.2	8	2.3	9	1.0
.026	0.66	0.8	3	1.2	5	1.4	5	1.6	6	1.8	7	2.0	8	2.1	8	2.2	8	2.3	9	2.4	9	2.6	10	2.7	10	1.1
.029	0.74	1.0	4	1.4	5	1.7	6	2.0	8	2.3	9	2.5	10	2.7	10	2.8	11	2.9	11	3.0	11	3.2	12	3.4	13	1.4
.032	0.81	1.2	5	1.7	6	2.1	8	2.5	10	2.8	11	3.0	11	3.3	13	3.4	13	3.5	13	3.7	14	3.9	15	4.1	16	1.7
.035	0.89	1.5	6	2.1	8	2.6	10	3.0	11	3.3	13	3.6	14	3.9	15	4.0	15	4.2	16	4.4	17	4.7	18	4.9	19	2.1
.038	0.97	1.7	6	2.5	10	3.0	11	3.5	13	3.9	15	4.3	16	4.6	18	4.8	18	4.9	19	5.2	20	5.5	21	5.7	22	2.5
.042	1.07	2.1	8	3.0	11	3.7	14	4.2	16	4.7	18	5.2	20	5.6	21	5.8	22	6.0	23	6.4	24	6.7	26	7.0	27	3.0
.047	1.19	2.7	10	3.8	14	4.6	18	5.3	20	5.9	22	6.5	25	7.0	27	7.3	28	7.5	29	8.0	30	8.4	32	8.8	34	3.8
.052	1.32	3.3	13	4.6	18	5.6	21	6.5	25	7.3	28	8.0	30	8.6	33	8.9	34	9.2	35	9.8	37	10	38	11	42	4.6
.057	1.45	3.9	15	5.5	21	6.8	26	7.8	30	8.7	33	9.6	37	10	38	11	42	11	42	12	46	12	46	13	50	5.5
.063	1.60	4.8	18	6.8	26	8.3	32	9.6	37	11	42	12	46	13	50	13	50	14	53	14	53	15	57	16	61	6.8
.069	1.78	5.7	22	8.1	31	9.9	38	12	46	13	50	14	53	15	57	16	61	16	61	17	65	18	69	19	72	8.1
.075	1.91	6.8	26	9.6	37	12	46	13	50	15	57	17	65	18	69	19	72	19	72	20	76	21	80	23	88	9.6
.082	2.08	7.2	27	10	38	13	50	14	53	16	61	18	69	19	72	20	76	20	76	22	83	23	88	24	91	10
.090	2.29	8.7	33	12	46	15	57	17	65	19	72	21	80	23	88	24	91	25	95	26	98	27	102	29	110	12
.098	2.49	10	38	15	57	18	69	21	80	23	88	25	95	27	102	28	106	29	110	31	117	33	125	34	129	15
.106	2.69	12	46	17	65	21	80	24	91	27	102	29	110	32	121	33	125	34	129	36	136	38	144	40	151	17
.115	2.92	14	53	20	76	25	95	28	106	32	121	35	132	37	140	39	148	40	151	42	159	45	170	47	178	20
.125	3.18	17	65	24	91	29	110	33	125	37	140	41	155	44	167	46	174	47	178	50	189	53	201	55	208	24
.135	3.43	20	76	28	106	34	129	39	148	44	167	48	182	52	197	53	201	55	208	58	220	62	235	65	246	28
.145	3.68	23	88	32	121	39	148	45	170	50	189	55	208	60	227	62	235	64	242	68	257	71	269	75	284	32
.155	3.94	26	98	36	136	45	170	51	193	57	216	63	238	68	257	70	265	73	276	77	291	81	307	85	322	36
.165	4.19	29	110	41	155	50	189	58	220	65	246	71	269	77	291	80	303	82	310	87	329	92	348	97	367	41

For the most accurate nozzle selection for your tool, use the Jetting App:
JETTING.STONEAGETOOLS.COM

CARBIDE ATTACK TIPS

StoneAge Attack Tips are the highest quality, longest lasting nozzles available for low and medium pressure applications (up to 22k psi/1500 bar). Carbide nozzles are a good selection for lower quality water or dirty water applications. They offer a high quality jet and great erosion resistance. Flow straighteners correct turbulence, ensuring excellent jetting results.

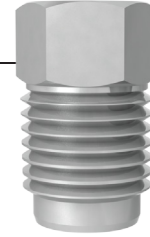

CNP2
1/8 NPT

NOZZLE FLOW CHART

Nozzle Size		PRESSURE (PSI & BAR)														Cd										
		2,000		4,000		6,000		8,000		10,000		12,000		14,000			15,000		16,000		18,000		20,000		22,000	
in.	mm	140	280	410	550	700	830	970	1000	1100	1200	1400	1500	1100	1200	1400	1500	1100	1200	1400	1500	1400	1500	1400	1500	
.018	0.46	0.4	2	0.6	2	0.7	3	0.8	3	0.9	3	1.0	4	1.0	4	1.1	4	1.1	4	1.2	5	1.2	5	1.3	5	0.6
.020	0.51	0.5	2	0.7	3	0.8	3	1.0	4	1.1	4	1.2	5	1.3	5	1.3	5	1.5	6	1.5	6	1.5	6	1.6	6	0.7
.022	0.56	0.6	2	0.8	3	1.0	4	1.2	5	1.3	5	1.4	5	1.5	6	1.6	6	1.6	6	1.7	6	1.8	7	1.9	7	0.8
.024	0.61	0.7	3	1.0	4	1.2	5	1.4	5	1.6	6	1.7	6	1.8	7	1.9	7	2.0	8	2.1	8	2.2	8	2.3	9	1.0
.026	0.66	0.8	3	1.2	5	1.4	5	1.6	6	1.8	7	2.0	8	2.1	8	2.2	8	2.3	9	2.4	9	2.6	10	2.7	10	1.1
.029	0.74	1.0	4	1.4	5	1.7	6	2.0	8	2.3	9	2.5	10	2.7	10	2.8	11	2.9	11	3.0	11	3.2	12	3.4	13	1.4
.032	0.81	1.2	5	1.7	6	2.1	8	2.5	10	2.8	11	3.0	11	3.3	13	3.4	13	3.5	13	3.7	14	3.9	15	4.1	16	1.7
.035	0.89	1.5	6	2.1	8	2.6	10	3.0	11	3.3	13	3.6	14	3.9	15	4.0	15	4.2	16	4.4	17	4.7	18	4.9	19	2.1
.038	0.97	1.7	6	2.5	10	3.0	11	3.5	13	3.9	15	4.3	16	4.6	18	4.8	18	4.9	19	5.2	20	5.5	21	5.7	22	2.5
.042	1.07	2.1	8	3.0	11	3.7	14	4.2	16	4.7	18	5.2	20	5.6	21	5.8	22	6.0	23	6.4	24	6.7	26	7.0	27	3.0
.047	1.19	2.7	10	3.8	14	4.6	18	5.3	20	5.9	22	6.5	25	7.0	27	7.3	28	7.5	29	8.0	30	8.4	32	8.8	34	3.8
.052	1.32	3.3	13	4.6	18	5.6	21	6.5	25	7.3	28	8.0	30	8.6	33	8.9	34	9.2	35	9.8	37	10	38	11	42	4.6
.057	1.45	3.9	15	5.5	21	6.8	26	7.8	30	8.7	33	9.6	37	10	38	11	42	11	42	12	46	12	46	13	50	5.5
.063	1.60	4.8	18	6.8	26	8.3	32	9.6	37	11	42	12	46	13	50	13	50	14	53	14	53	15	57	16	61	6.8
.069	1.78	5.7	22	8.1	31	9.9	38	12	46	13	50	14	53	15	57	16	61	16	61	17	65	18	69	19	72	8.1
.075	1.91	6.8	26	9.6	37	12	46	13	50	15	57	17	65	18	69	19	72	19	72	20	76	21	80	23	88	9.6
.082	2.08	8.1	31	12	46	14	53	16	61	18	69	20	76	21	80	22	84	23	88	24	91	26	99	27	103	12
.090	2.29	9.8	37	14	53	17	65	20	76	22	84	24	91	26	99	27	103	28	107	29	111	31	118	32	122	14
.098	2.49	12	46	16	61	20	76	23	88	26	99	28	107	31	118	32	122	33	126	35	133	37	141	38	145	16
.106	2.69	14	53	19	72	23	88	27	103	30	114	33	126	36	137	37	141	38	145	41	156	43	164	45	171	19
.115	2.92	16	61	23	88	28	107	32	122	36	137	39	149	42	160	44	168	45	171	48	183	50	191	53	202	23
.125	3.18	17	65	27	103	33	126	38	145	42	160	46	175	50	191	52	198	53	202	56	213	60	229	62	236	27
.135	3.43	22	84	31	118	38	145	44	168	49	187	54	206	58	221	60	229	62	236	66	252	69	263	73	278	31
.145	3.68	25	95	36	137	44	168	51	194	57	217	62	236	67	255	69	263	72	274	76	290	80	305	84	320	36

For the most accurate nozzle selection for your tool, use the Jetting App:

JETTING.STONEAGETOOLS.COM

OCV & OCIH CARBIDE NOZZLES

We recommend using carbide nozzle tips where filtration is poor, abrasive solids are present, or for very high flow.

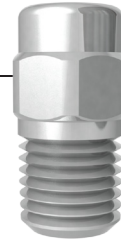

OCV
1/4 NPT



OCIH
1/4 NPT

NOZZLE FLOW CHART

Nozzle Size		PRESSURE (PSI & BAR)																#				
		2,000 140		4,000 280		6,000 410		8,000 550		10,000 700		12,000 830		14,000 970		16,000 1100			18,000 1200		20,000 1400	
in.	mm																					
.024	0.61	0.7	3	1.0	4	1.2	4.5	1.4	5	1.6	6	1.7	6	1.8	7	2.0	8	2.1	8	2.2	8	1.0
.028	0.71	0.9	3	1.3	5	1.6	5	1.9	7	2.1	8	2.3	9	2.5	10	2.7	10	2.8	11	3.0	11	0.7
.031	0.79	1.2	5	1.6	6	2.0	8	2.3	9	2.6	10	2.8	11	3.1	12	3.3	13	3.5	13	3.7	14	1.6
.036	0.91	1.7	6	2.4	9	3.0	11	3.4	13	3.8	14	4.2	16	4.5	17	4.8	18	5.1	19	5.4	20	2.4
.039	0.99	1.8	7	2.6	10	3.2	12	3.7	14	4.1	16	4.5	17	4.9	19	5.2	20	5.5	21	5.8	22	2.6
.043	1.09	2.2	8	3.2	12	3.9	15	4.5	17	5.0	19	5.5	21	5.9	22	6.3	24	6.7	25	7.0	26	3.2
.047	1.19	2.7	10	3.8	14	4.6	18	5.3	20	6.0	23	6.5	25	7.0	26	7.5	28	8.0	30	8.4	32	3.8
.055	1.40	3.6	14	5.2	20	6.3	24	7.3	28	8.1	31	8.9	34	9.6	36	10	38	11	42	12	45	5.2
.062	1.57	4.6	18	6.5	25	8.0	30	9.3	35	10	38	11	42	12	45	13	49	14	53	15	57	6.5
.067	1.70	5.4	20	7.6	29	9.4	36	11	42	12	45	13	49	14	53	15	57	16	61	17	64	7.6
.073	1.85	6.4	24	9.1	34	11	42	13	49	14	53	16	61	17	64	18	68	19	72	20	76	9.1
.078	1.98	7.3	28	10	38	13	49	15	57	16	61	18	68	19	72	21	79	22	83	23	87	10
.089	2.26	9.5	36	14	53	16	61	19	72	21	79	23	87	25	95	27	102	29	110	30	114	14
.093	2.36	10	38	15	57	18	68	21	79	23	87	26	98	28	106	30	114	31	117	33	125	15
.106	2.69	14	53	19	72	23	87	27	102	30	114	33	125	36	136	38	144	41	155	43	163	19
.125	3.18	19	72	27	102	33	125	38	144	42	159	46	174	50	189	53	201	56	212	60	227	27
.140	3.56	24	91	33	125	41	155	47	178	53	201	58	220	62	235	67	254	71	269	75	284	33
.155	3.94	29	110	40	151	49	185	57	216	64	242	70	265	76	288	83	314	88	333	93	352	41

For the most accurate nozzle selection for your tool, use the Jetting App:

JETTING.STONEAGETOOLS.COM

OC8 CARBIDE NOZZLES

We recommend using our OC8 Holders and OC8 Carbide Inserts where filtration is poor, abrasive solids are present or for very high flow applications. Replaceable carbide inserts are available in large orifice diameters to handle high flows and contain a long taper to provide excellent jet quality.

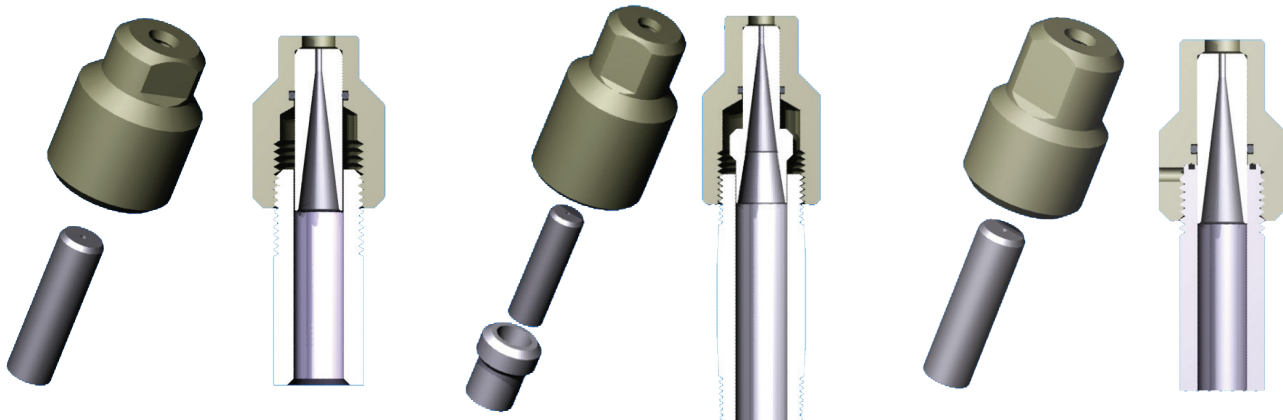

The **OC8 P8** Holder and OC Carbide Inserts for 15K psi, 1/2 NPT female connection.

The **OC8 P12** Holder and OC Carbide Inserts for 15K psi, 3/4 NPT female connection.

The **OC8 G12** Holder and OC Carbide Inserts for 22K psi, G12 female connection.

NOZZLE FLOW CHART

Nozzle Size		PRESSURE (PSI & BAR)														Cd										
		2,000		4,000		6,000		8,000		10,000		12,000		14,000			15,000		16,000		18,000		20,000		22,000	
in.	mm	140	280	410	550	700	830	970	1000	1100	1200	1400	1500	1500	1500	1500	1500	1500	1500	1500	1500	1500	1500	1500	1500	1500
.063	1.60	4.8	18	6.7	26	8.2	31	9.5	36	11	42	12	46	13	50	13	50	14	53	14	53	15	57	16	61	7
.075	1.91	6.8	26	9.6	37	12	46	14	53	15	57	17	65	18	69	19	72	19	72	20	76	21	80	22	84	10
.085	2.16	8.7	33	12	46	15	57	17	65	19	72	21	80	23	88	24	91	25	95	26	99	28	107	129	492	12
.095	2.41	11	42	15	57	19	72	22	84	24	91	27	103	29	111	30	114	31	118	33	126	33	126	36	137	15
.105	2.67	13	50	19	72	23	88	27	103	30	114	33	126	35	133	36	137	38	145	40	152	42	160	44	168	19
.125	3.18	19	72	27	103	33	126	38	145	42	160	46	175	50	191	52	198	53	202	56	213	60	229	62	236	27
.145	3.68	25	95	36	137	44	168	50	191	57	217	62	236	67	255	69	263	72	274	76	290	80	305	84	320	36
.165	4.19	33	126	46	175	56	213	66	252	73	278	80	305	87	332	90	343	93	354	98	373	104	396	109	415	46
.175	4.45	37	141	52	198	64	244	74	282	82	313	90	343	98	373	101	385									52
.190	4.83	43	164	61	232	75	286	87	332	97	370	106	404	115	438	119	454									61
.200	5.08	48	183	68	259	83	316	96	366	108	412	118	450	127	484	132	503									68
.215	5.46	56	213	79	301	96	366	111	423	124	473															78
.235	5.97	66	252	94	358	115	438	133	507	149	568															94
.250	6.35	75	286	106	404	130	495	150	572	168	640															106

For the most accurate nozzle selection for your tool, use the Jetting App:

JETTING.STONEAGETOOLS.COM

SAPPHIRE NOZZLES

These nozzles are used for 40k psi (2800 bar) jetting applications where water filtration of 10 micron or better is required. Jeweled orifices make the best quality, longest lasting jets possible for ultra-high pressures.

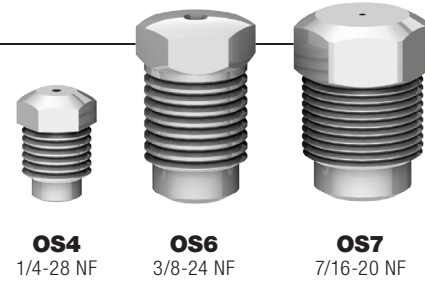

NOZZLE FLOW CHART

Nozzle Size		PRESSURE (PSI & BAR)														Availability										
		20,000 1400		22,000 1500		24,000 1700		26,000 1800		28,000 1900		30,000 2100		32,000 2200		34,000 2300		36,000 2500		38,000 2600		40,000 2800		OS4	OS6	OS7
in.	mm																									
.009	0.23	0.2	1	0.2	1	0.2	1	0.3	1	0.3	1	0.3	1	0.3	1	0.3	1	0.3	1	0.3	1	0.3	1		•	
.010	0.25	0.3	1	0.3	1	0.3	1	0.3	1	0.3	1	0.4	2	0.4	2	0.4	2	0.4	2	0.3	1	0.4	2	•	•	
.011	0.28	0.3	1	0.4	2	0.4	2	0.4	2	0.4	2	0.4	2	0.4	2	0.4	2	0.5	2	0.5	2	0.5	2		•	•
.012	0.30	0.4	2	0.4	2	0.4	2	0.4	2	0.5	2	0.5	2	0.5	2	0.5	2	0.5	2	0.6	2	0.6	2	•	•	•
.013	0.33	0.5	2	0.5	2	0.5	2	0.5	2	0.6	2	0.6	2	0.6	2	0.6	2	0.6	2	0.6	2	0.7	3	•	•	•
.014	0.36	0.5	2	0.6	2	0.6	2	0.6	2	0.6	2	0.7	3	0.7	3	0.7	3	0.7	3	0.7	3	0.8	3	•	•	•
.015	0.38	0.6	2	0.7	3	0.7	3	0.7	3	0.7	3	0.8	3	0.8	3	0.8	3	0.8	3	0.9	3	0.9	3	•	•	•
.016	0.41	0.7	3	0.7	3	0.8	3	0.8	3	0.8	3	0.9	3	0.9	3	0.9	3	1.0	4	1.0	4	1.0	4	•	•	•
.017	0.43	0.8	3	0.8	3	0.9	3	0.9	3	0.9	3	1.0	4	1.0	4	1.0	4	1.1	4	1.1	4	1.1	4	•	•	•
.018	0.46	0.9	3	0.9	3	1.0	4	1.0	4	1.1	4	1.1	4	1.1	4	1.2	5	1.2	5	1.2	5	1.3	5	•	•	•
.019	0.48	1.0	4	1.0	4	1.1	4	1.1	4	1.2	5	1.2	5	1.3	5	1.3	5	1.3	5	1.4	5	1.4	5	•	•	•
.020	0.51	1.1	4	1.2	5	1.2	5	1.3	5	1.3	5	1.4	5	1.4	5	1.4	5	1.5	6	1.5	6	1.6	6	•	•	•
.021	0.53	1.2	5	1.3	5	1.3	5	1.4	5	1.4	5	1.5	6	1.5	6	1.6	6	1.6	6	1.7	6	1.7	6	•	•	•
.022	0.56	1.3	5	1.4	5	1.5	6	1.5	6	1.6	6	1.6	6	1.7	6	1.7	6	1.8	7	1.8	7	1.9	7	•	•	•
.023	0.58	1.5	6	1.5	6	1.6	6	1.7	6	1.7	6	1.7	6	1.8	7	1.9	7	1.9	7	2.0	8	2.0	8	•	•	•
.024	0.61	1.6	6	1.7	6	1.7	6	1.8	7	1.9	7	1.9	7	2.0	8	2.1	8	2.1	8	2.2	8	2.2	8	•	•	•
.025	0.64	1.7	6	1.8	7	1.9	7	2.0	8	2.0	8	2.1	8	2.2	8	2.2	8	2.3	9	2.4	9	2.4	9	•	•	•
.026	0.66	1.9	7	1.9	7	2.0	8	2.1	8	2.2	8	2.3	9	2.3	9	2.4	9	2.5	10	2.6	10	2.6	10	•	•	
.027	0.69	2.0	8	2.1	8	2.2	8	2.3	9	2.4	9	2.5	10	2.5	10	2.6	10	2.7	10	2.8	11	2.8	11	•	•	
.028	0.71	2.2	8	2.3	9	2.4	9	2.5	10	2.6	10	2.5	10	2.7	10	2.8	11	2.9	11	3.0	11	3.1	12	•	•	•
.031	0.79	2.6	10	2.8	11	2.9	11	3.0	11	3.1	12	3.2	12	3.3	13	3.4	13	3.5	13	3.6	14	3.7	14	•	•	•
.033	0.84	3.0	11	3.1	12	3.3	13	3.4	13	3.5	13	3.7	14	3.8	14	3.9	15	4.0	15	4.1	16	4.2	16			•
.034	0.86	3.2	12	3.3	13	3.5	13	3.6	14	3.8	14	3.9	15	4.0	15	4.2	16	4.3	16	4.4	17	4.5	17	•	•	
.035	0.89	3.4	13	3.5	13	3.7	14	3.8	14	4.0	15	4.1	16	4.3	16	4.4	17	4.5	17	4.6	18	4.8	18	•		•

For the most accurate nozzle selection for your tool, use the Jetting App:

JETTING.STONEAGETOOLS.COM