

PART NUMBER  
**SSA57**



**BEFORE YOU BEGIN**

**TOOLS REQUIRED**

- > Floor Jack
- > Safety Jack Stands
- > Wheel Chocks
- > 3/4" Wrench/Sockets
- > 9/16" Wrench/Sockets
- > SuperSpring Installation Tool or C-Clamp

**PRIMARY APPLICATIONS**

- > Chevrolet Silverado 1500 4X2 (2025 - present)
- > Chevrolet Silverado 1500 4X4 (2025 - present)
- > GMC Sierra 1500 4X2 (2025 - present)
- > GMC Sierra 1500 4X4 (2025 - present)

**PARTS LIST**

Item	Part #	Description	QTY
A	102008	SuperSpring SSA57	2
B	PSP-8	Polyurethane Spring Pad	2
C	112251	Springs Clamp	2
D	512301	3/8-16 x 1 1/2" Flange Bolt	2
E	512302	3/8-16 Locking Flange Nut	2
F	112170	1/2"-13 x 4 3/4" Hex Bolt	4
G	112126	1/2-13 Nylock Nut	8
H	112189	HDPE Roller	4
I	112171	Steel Sleeve	4
J	122414	Shackle Leg 4 Holes	8
K	112127	1/2" Nylon Washer	16
L	112124	1/2"-13 x 2 3/4" Hex Bolt	4
M	112140	Polyurethane Bushing	8

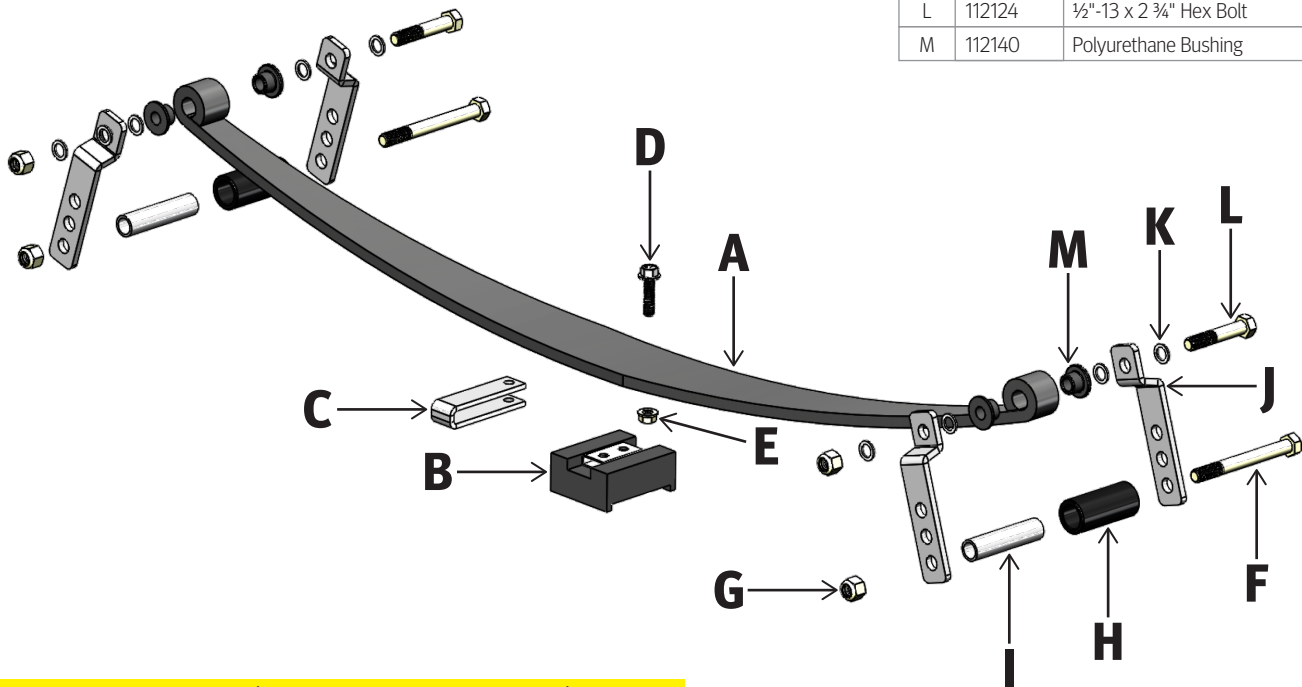

**DRIVER SIDE (PASSENGER SIDE SIMILAR)**

**Part Number: SSA57**

**Product Line: SUPERSPRINGS**

**Page 1**

Questions or Concerns?

Scan here:



or visit:  
[superspringsinternational.com](http://superspringsinternational.com)

**SAFETY NOTICE:** We recommend installation be done by a professional or persons with sound mechanical knowledge.

**WARNING:** These instructions are a general guide for installation. SuperSprings International (SSI) assumes no liability for the actual installation process. Consumers and installers should apply common automotive safety practices when raising and working on any vehicle. **Do not put yourself in a position where, if the vehicle were to move unexpectedly, you may be injured.** SSI's products are designed to improve vehicle ride quality. Do not load any vehicle beyond the manufacturer's specifications.

**Never exceed the manufacturer's Gross Vehicle Rating (GVWR) located on your vehicles identification tag.**

**BEFORE INSTALLATION:** Ensure the vehicle is on a hard level surface, the parking brake is ON, with the ignition OFF, and place chocks in front of and behind the tires to prevent the vehicle from moving.

**DURING AND/OR AFTER INSTALLATION:** Ensure emergency brake cables are not touching the SSI products. Secure any cables out of the way with zip ties or by re-routing. Ensure all A/C lines, brake cables, and frame are clear of contact or interference.

PART NUMBER

**SSA57**



**INSTALLATION**

1. Park the vehicle on a hard, level surface and engage the emergency brake and turn off ignition. Place chocks in front and behind wheels to prevent rolling. Observe all safety precautions and wear safety glasses.
2. Raise the rear of vehicle to allow the axle to hang freely and support the frame using safety jack stands. Removal of the wheel is optional, but will make installation easier.
3. The SSA57 does not have a dedicated front/rear. However, the threaded ends of the spring eye bolts should be pointing outboard, away from the frame.
4. Using  $\frac{3}{4}$ " tools, wrenches / sockets / ratchet, remove and set aside the Bolts [ITEM F] and Nuts [ITEM G] retaining the Rollers [ITEM H] and Sleeves [ITEM I] from the front and rear of the shackles. Rotate the shackles toward the center and parallel to the spring.
5. Place PSP-8 pad [ITEM B] on the spring-plate between the factory u-bolts with steel channel facing up as in the diagram. Ensure the cutout at the end of the steel channel is facing inboard.
6. Place the SSA57 SuperSpring [ITEM A] so it is resting on the PSP-8 [ITEM B] above the factory leaf pack. Ensure that the threads of the spring eye bolts are facing outboard away from the frame.
7. Slide the Spring Clamp [ITEM C] around the SuperSpring and through the steel channel of the PSP-8 from the outboard side so the holes are inboard.
8. Insert the  $\frac{3}{8}$ -16 x 1  $\frac{1}{2}$ " Flange Bolt [ITEM D] down through the two holes of the Spring clamp and install the  $\frac{3}{8}$ " Locking Flange Nut [ITEM E] leaving it loose for now.
9. Shackle Attachment - [Note: The top/spring eye shackle bolts are factory pre-torqued; no adjustment/further tightening is needed. If any are loosened by the installer then retorque to 30 ft. lbs.

**SHACKLE ATTACHMENT FRONT** - Rotate the front shackles legs down on both sides of the leaf spring. Adjust the position front to rear so the shackle is located just behind the front factory spring clip. Using ITL-1 or other high capacity clamp(s), compress the SuperSprings and factory leaf pack together. Place the Sleeve [ITEM I] and the Roller [ITEM H] between the Shackle legs and align with middle hole. Secure with the  $\frac{1}{2}$ -13 x 4  $\frac{3}{4}$ " Hex Bolt [ITEM F] and  $\frac{1}{2}$ -13 Lock Nut [ITEM G]. Ensure the threads of the bolts are facing outboard, away from the frame. Torque to 35 ft. lbs.

**Part Number: SSA57**

**Product Line: SUPERSPRINGS**

**Page 2**

Questions or Concerns?

Scan here:



or visit:  
[superspringsinternational.com](http://superspringsinternational.com)

**SAFETY NOTICE:** We recommend installation be done by a professional or persons with sound mechanical knowledge.

**WARNING:** These instructions are a general guide for installation. SuperSprings International (SSI) assumes no liability for the actual installation process. Consumers and installers should apply common automotive safety practices when raising and working on any vehicle. **Do not put yourself in a position where, if the vehicle were to move unexpectedly, you may be injured.** SSI's products are designed to improve vehicle ride quality. Do not load any vehicle beyond the manufacturer's specifications.

**Never exceed the manufacturer's Gross Vehicle Rating (GVWR) located on your vehicles identification tag.**

**BEFORE INSTALLATION:** Ensure the vehicle is on a hard level surface, the parking brake is ON, with the ignition OFF, and place chocks in front of and behind the tires to prevent the vehicle from moving.

**DURING AND/OR AFTER INSTALLATION:** Ensure emergency brake cables are not touching the SSI products. Secure any cables out of the way with zip ties or by re-routing. Ensure all A/C lines, brake cables, and frame are clear of contact or interference.

REV. 1 | OCT 2025

PART NUMBER  
**SSA57**



**INSTALLATION**

**SHACKLE ATTACHMENT REAR** – Rotate the rear shackles legs down on both sides of the leaf spring. Using a heavy-duty clamp or SuperSprings installation tool, compress the rear of the SuperSpring and attach the rear shackle in the same way as the front. The rear shackle should be positioned behind the rear spring clip with ½ to 1" clearance between the roller and the clip. If the plastic tang on the bottom of the factory leaf interferes with the roller, chisel or grind it off flush. Torque to 35 ft. lbs.

10. Confirm that there is adequate clearance around the SuperSpring from the frame, brake lines, harnesses, etc. In some cases, it may be necessary to bend routing brackets to adjust position of the brake lines or harnesses for clearance.

**NOTE:** The center holes of the shackle are meant to be a starting point for preload. If less preload is desired the lower holes may be used. If more preload is required, the upper holes may be used. Start by adjusting only the front shackle first, and then the rear.

11. Tighten Bolt [ITEM D] and Nut [ITEM E] to clamp the Spring Clip [ITEM C] securely to the SuperSpring.

12. Repeat steps 3 through 11 on the passenger side of the vehicle.

13. Lower the vehicle – raise chassis, remove the jack stands, lower to the ground. Remove wheel chocks from front wheels.

14. Check the position of the SuperSprings ensuring correct hardware application and orientation. Observe all hardware ensuring proper static and dynamic interference clearances. Recheck all hardware to ensure it is securely tightened.

**NOTE:** After 200-500 miles of driving, recheck all hardware again for tightness.

15. Register the warranty for your SuperSprings International part. A warranty card can be found at the top of the sticker pack that came with your parts.

**Part Number: SSA57**

**Product Line: SUPERSPRINGS**

**Page 3**

Questions or Concerns?

Scan here:



or visit:  
[superspringsinternational.com](http://superspringsinternational.com)

**SAFETY NOTICE:** We recommend installation be done by a professional or persons with sound mechanical knowledge.

**WARNING:** These instructions are a general guide for installation. SuperSprings International (SSI) assumes no liability for the actual installation process. Consumers and installers should apply common automotive safety practices when raising and working on any vehicle. **Do not put yourself in a position where, if the vehicle were to move unexpectedly, you may be injured.** SSI's products are designed to improve vehicle ride quality. Do not load any vehicle beyond the manufacturer's specifications.

**Never exceed the manufacturer's Gross Vehicle Rating (GVWR) located on your vehicles identification tag.**

**BEFORE INSTALLATION:** Ensure the vehicle is on a hard level surface, the parking brake is ON, with the ignition OFF, and place chocks in front of and behind the tires to prevent the vehicle from moving.

**DURING AND/OR AFTER INSTALLATION:** Ensure emergency brake cables are not touching the SSI products. Secure any cables out of the way with zip ties or by re-routing. Ensure all A/C lines, brake cables, and frame are clear of contact or interference.

REV. 1 | OCT 2025