

PART NUMBER  
**SSA56**



## BEFORE YOU BEGIN

### TOOLS REQUIRED

- › Floor Jack
- › Safety Jack Stands
- › Wheel Chocks
- › 1-1/16" Wrench/Socket
- › 1-1/8" Wrench/Socket
- › 9/16" Wrench/Socket
- › Heavy Duty Clamps or SuperSprings Installation Tool

### PRIMARY APPLICATIONS

- › Dodge Sprinter 3500 4X2 (2004 - 2009)
- › Dodge Sprinter 3500 4X4 (2004 - 2009)
- › Freightliner Sprinter 3500 4X2 (2007 - 2021)
- › Freightliner Sprinter 3500 4X4 (2007 - 2021)
- › Mercedes-Benz Sprinter 3500 4X2 (2010 - present)
- › Mercedes-Benz Sprinter 3500 4X4 (2010 - present)
- › Mercedes-Benz Sprinter 4500 4X2 (2017 - present)

### PARTS LIST

Item	Part #	Description	QTY
A	102056	SSA56 Leaf Spring	2
B	122473	Shackle	4
C	PSP-8	Polyurethane Spring Pad	2
D	112252	Spring Clamp	2
E	112151	Leaf Spring Isolator	2
F	112160	Polyurethane Bushing	8
G	112150	3/4-10 x 5" Hex Bolt Grade 8 with Head cut to 1/4" tall	4
H	112145	3/4-10 Lock Nut Grade 8	4
I	112146	3/4" Nylon Flat Washer	8
J	512301	3/8-16 x 1 1/2" Flange Bolt	2
K	512302	3/8-16 Locking Flange Nut	2
L	112152	UHMW Slider for SSA56	4

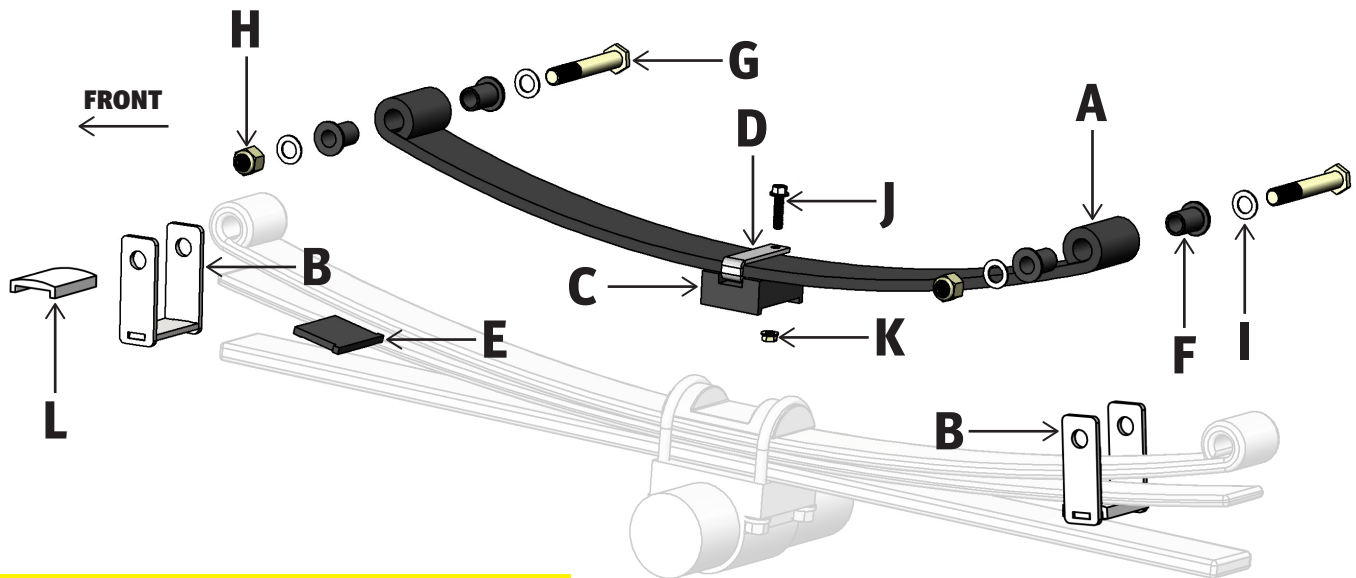

**DRIVER SIDE (PASSENGER SIDE SIMILAR)**

Part Number: SSA56

Product Line: SUPERSPRINGS

Page 1

Questions or Concerns?

Scan here:



or visit:  
superspringsinternational.com

**SAFETY NOTICE:** We recommend installation be done by a professional or persons with sound mechanical knowledge.

**WARNING:** These instructions are a general guide for installation. SuperSprings International (SSI) assumes no liability for the actual installation process. Consumers and installers should apply common automotive safety practices when raising and working on any vehicle. **Do not put yourself in a position where, if the vehicle were to move unexpectedly, you may be injured.** SSI's products are designed to improve vehicle ride quality. Do not load any vehicle beyond the manufacturer's specifications.

Never exceed the manufacturer's Gross Vehicle Rating (GVWR) located on your vehicles identification tag.

**BEFORE INSTALLATION:** Ensure the vehicle is on a hard level surface, the parking brake is ON, with the ignition OFF, and place chocks in front of and behind the tires to prevent the vehicle from moving.

**DURING AND/OR AFTER INSTALLATION:** Ensure emergency brake cables are not touching the SSI products. Secure any cables out of the way with zip ties or by re-routing. Ensure all A/C lines, brake cables, and frame are clear of contact or interference.

REV. 2.02 | AUG 2025

PART NUMBER  
**SSA56**



## INSTALLATION

1. Park the vehicle on a hard, level surface. Ensure emergency brake is ON and the ignition is OFF. Place chocks in front and behind the front wheels to prevent rolling. Observe all safety precautions and wear safety glasses.
  2. Raise the rear of vehicle to allow the axle to hang freely and support the frame using safety jack stands. It is highly recommended to remove the rear wheels and use a SuperSprings Installation Tool (ITL-1 or ITL-2).
- NOTE:** This spring model does NOT employ our patented self-adjusting shackle roller mechanisms. This shackle, isolator insert, and UHMW slider have unique placements that are important elements of this design. Ensure adequate space for the SuperSpring assembly prior to install.
3. Place PSP-8 [ITEM C] on the spring-plate between the factory U-bolts, with the steel channel facing up and the deeper channel facing inboard.
  4. Place the SuperSpring [ITEM A] so it is resting on the PSP-8 [ITEM C] above the factory leaf pack.
  5. Insert the Spring Clamp [ITEM D] through the PSP-8 [ITEM C] and over the SuperSpring [ITEM A], from the outboard side so the holes are inboard.
  6. Insert the 3/8-16 x 1 1/2" Flange Bolt [ITEM J] down through the holes of the Spring Clamp [ITEM D] and install the 3/8" Locking Flange Nut [ITEM K] leaving it loose.

7. Adjust the position of the SuperSpring [ITEM A] front to back so that the rear of the SuperSpring is within the frame rail enclosure as seen from below. Ensure the rear Shackle [ITEM B] has a 1/4" of clearance from the factory silicon sock. Confirm the SuperSpring blade and shackle will not collide with the frame or other components during suspension travel.
8. Insert the Leaf Spring Isolator [ITEM E] between the top and middle leaves, with the side tabs closest to the axle.

**NOTE:** The use of a pry tool may help to ease installation of the Leaf Spring Isolator [ITEM E].

9. Starting with the front, position the Shackle [ITEM B] by angling the legs of the shackle toward the axle, sliding the shackle into place between the bottom and middle leaf blades, and rotate upwards. Slide the Shackle [ITEM B] over the Leaf Spring Isolator [ITEM E] until the side tabs come into contact with the legs, adjusting the placement of the shackle and leaf spring isolator as needed.

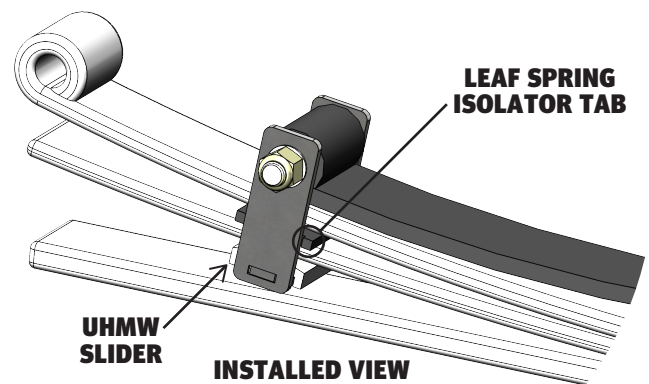

Part Number: SSA56

Product Line: SUPERSPRINGS

Page 2

Questions or Concerns?

Scan here:



or visit:  
[superspringsinternational.com](http://superspringsinternational.com)

**SAFETY NOTICE:** We recommend installation be done by a professional or persons with sound mechanical knowledge.

**WARNING:** These instructions are a general guide for installation. SuperSprings International (SSI) assumes no liability for the actual installation process. Consumers and installers should apply common automotive safety practices when raising and working on any vehicle. **Do not put yourself in a position where, if the vehicle were to move unexpectedly, you may be injured.** SSI's products are designed to improve vehicle ride quality. Do not load any vehicle beyond the manufacturer's specifications.

Never exceed the manufacturer's Gross Vehicle Rating (GVWR) located on your vehicles identification tag.

**BEFORE INSTALLATION:** Ensure the vehicle is on a hard level surface, the parking brake is ON, with the ignition OFF, and place chocks in front of and behind the tires to prevent the vehicle from moving.

**DURING AND/OR AFTER INSTALLATION:** Ensure emergency brake cables are not touching the SSI products. Secure any cables out of the way with zip ties or by re-routing. Ensure all A/C lines, brake cables, and frame are clear of contact or interference.

REV. 2.02 | AUG 2025

PART NUMBER  
**SSA56**



**INSTALLATION**

10. Before attaching the shackle [ITEM B] to the SuperSpring [ITEM A], make sure to insert the Polyurethane Bushings [ITEM F] into the spring eye of the SuperSpring and insert the UHMW slider [ITEM L] between the shackle and the leaf directly above it, make sure the shackle sits firmly in the cutout on the slider. Begin attaching the shackle [ITEM B] to the SuperSpring eye [ITEM A] by putting a nylon flat washer [ITEM I] onto the 3/4-10 x 5" Hex Bolt [ITEM G] and inserting it through the shackle [ITEM B] and the spring eye of the SuperSpring, place another nylon flat washer onto the other end of the bolt and put the 3/4-10 Lock Nut [ITEM H] onto the threads of the 3/4-10 x 5" Hex Bolt [ITEM G]. Torque to 35 ft. lbs.

11. Using a heavy-duty C-Clamp or SuperSprings installation tool, compress the rear of the SuperSpring and attach the rear shackle in the same way as the front by repeating steps 9 and 10, without a Leaf Spring Isolator.

12. Ensure that there is adequate clearance of the SuperSprings in all areas. Check the front inboard spring edge and bolt head clearance in relation to the front outboard frame above the spring. Check the rear of the SuperSpring and its clearance to the rear frame. Consider vertical suspension travel clearance as well. If any clearance issues are found, adjust the spring front to back as needed.

13. Tighten the Spring Clamp hardware [ITEMS J & K].

14. Repeat steps 3 through 13 on the other side of the vehicle.

15. Reinstall wheels and torque lug nuts to factory specifications.

16. Lower the vehicle and remove all jacks and chocks. Recheck installation to confirm proper clearance of the SuperSprings to all AC lines, brake lines, body, and chassis components.

17. Register the warranty for your SuperSprings International part. A warranty card can be found in the box your part came in.

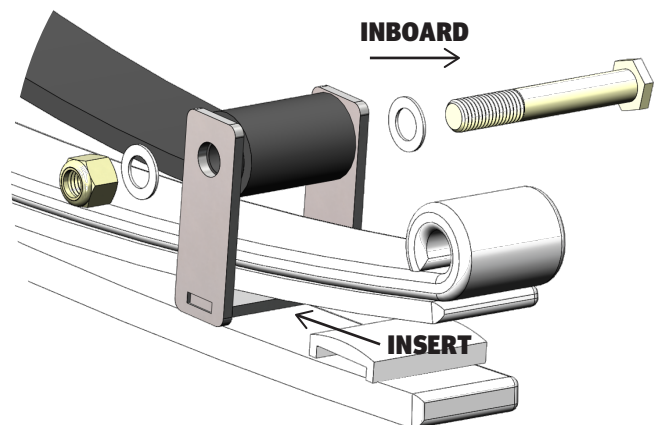

**Part Number: SSA56**

**Product Line: SUPERSPRINGS**

**Page 3**

Questions or Concerns?

Scan here:



or visit:  
[superspringsinternational.com](http://superspringsinternational.com)

**SAFETY NOTICE:** We recommend installation be done by a professional or persons with sound mechanical knowledge.

**WARNING:** These instructions are a general guide for installation. SuperSprings International (SSI) assumes no liability for the actual installation process. Consumers and installers should apply common automotive safety practices when raising and working on any vehicle. **Do not put yourself in a position where, if the vehicle were to move unexpectedly, you may be injured.** SSI's products are designed to improve vehicle ride quality. Do not load any vehicle beyond the manufacturer's specifications.

**Never exceed the manufacturer's Gross Vehicle Rating (GVWR) located on your vehicles identification tag.**

**BEFORE INSTALLATION:** Ensure the vehicle is on a hard level surface, the parking brake is ON, with the ignition OFF, and place chocks in front of and behind the tires to prevent the vehicle from moving.

**DURING AND/OR AFTER INSTALLATION:** Ensure emergency brake cables are not touching the SSI products. Secure any cables out of the way with zip ties or by re-routing. Ensure all A/C lines, brake cables, and frame are clear of contact or interference.

REV. 2.02 | AUG 2025