

Xsite®

Hardwire Components

Tools Required

- Cordless Drill/Driver
- 3/16" Allen Bit
- Flat Blade Screwdriver
- #2 Phillips Screwdriver

Installation

Note: Decora style receptacles, wires, EMT listed conduit, and fittings to be supplied by contractor.

Warning: Connection to building power must be completed by a licensed electrician. Installation must be in accordance with National Electrical Code and local codes.

1. Raise junction box up and slide tabs on top into large slots in bottom channel. Install using bolt and receiver through tabs and bottom channel. (Figure A). Fully tighten.
2. Electrical contractor hardwires conduit and receptacle. Conduit box fittings, wiring and receptacles to be supplied by contractor.
3. Mount receptacle to outside of cover plate with screws supplied in receptacle.

Note: Ground clip is supplied by electrician.

4. Install cover plates on front and back of box using four #8-32 x 1/4" screws provided. (Figure B). When installing cover plates for power the narrow side should be towards center of frame.
5. Install base wireway cover by engaging bottom flange of cover under wireway bracket at both verticals. Swing cover up and press top flange over top of brackets at both verticals. (Figure C).

Figure A

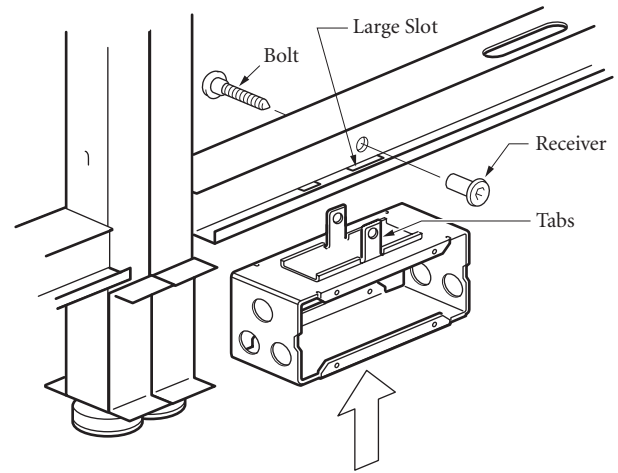

Figure B

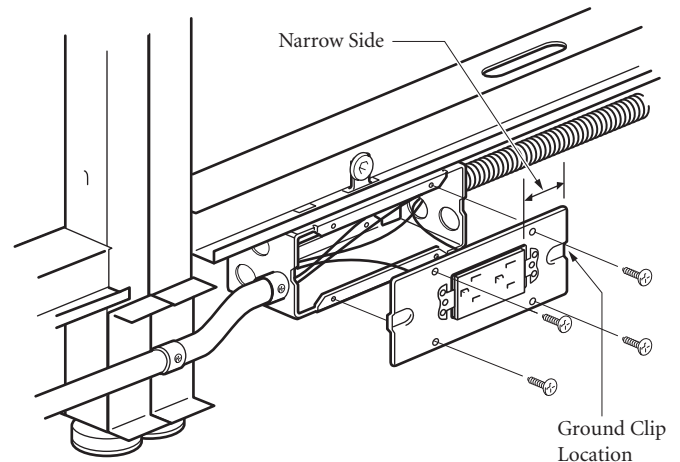
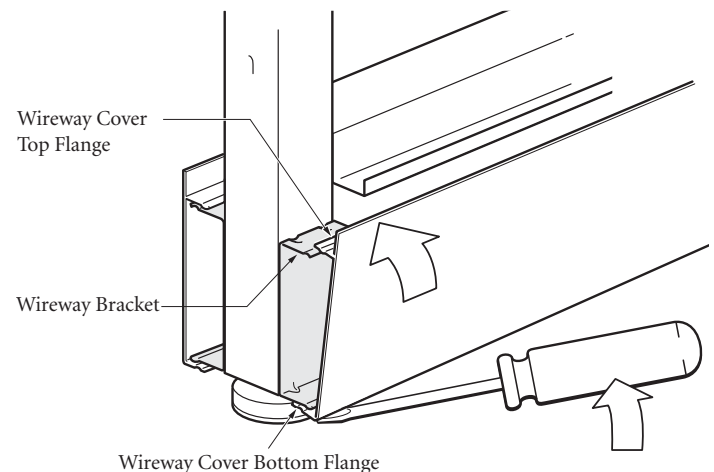

Figure C



Proper product installation, in accordance with these instructions, is the responsibility of the installing agent. If you have any questions concerning these instructions, please call Kimball Office Customer Service.

Kimball Office