

ACCESSORY RAIL

Tools Required

- Cordless driver with magnetic post and following tips
 - Flathead Screw Driver

Hardware Required (Included)

Quantity varies by model

- 4 or 2 -Nylon Glass Retaining Clip,
- 4 or 2 -Truss Head Slotted 8-32 X 3/8" Machine Screw
- 4 or 2—1/2" OD, 1/4" ID X 5/16" Plastic Spacer.

Installation

1. Unpack Accessory Rail and hardware.
2. Align Accessory Rail down the center of the bench as shown in Figure A. If 2 or more Accessory Rails are being installed end to end, in a row, then the end caps should be removed on the end where the accessory rails but together.
3. Insert Glass Retaining Clips into top of Accessory Rail at each hole location.
4. Press the Plastic Spacer over the end of Glass Retaining Clip from below, as seen in Figure A.
5. Using a Flathead Screw Driver, Start the Machine Screw in to the bottom of the retaining bracket. Hold accessory rail 5/16" off horizontal rail as seen in Figure B.
6. Install the Glass, Resin or Fabric Insert (Sold Separately) into the Accessory Rail and complete the process by tightening the Machine Screws.
7. Remove end caps on accessory rails if there are adjacent end cabinets, filler or accessory rail.

Figure A

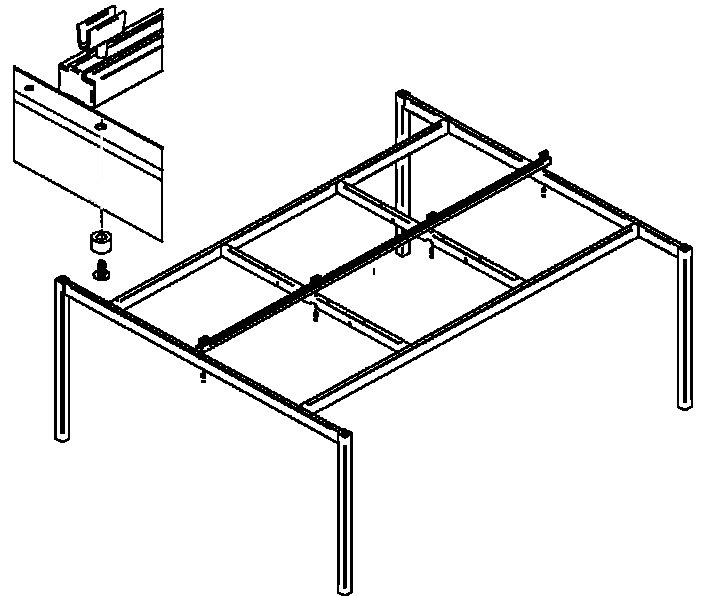

Figure B

