

Undersurface Shelves and Power Modules

Tools Required

- Cordless driver with magnetic post and following tips
 - #2 Phillips Hex Drive

Hardware Required (Included)

- 4 Pan Head Phillips #10 X 5/8"
- 4 Washers 3/8" OD, 3/16" ID, 3/64" THICK

Installation

1. Unpack shelves/power module and hardware.
2. Mark the location on the underside of the worksurface for mounting screw location, as shown in Figure A.
3. Using double stick tape or scotch tape, tape the included 4 washers to the underside of the worksurface, at the targeted hole locations. These washers will act as spacers and help locate correct screw location in the following step.
4. Using the included Pan Head screws, Attach the metal mounting plate to the underside of the surface in the orientation as shown in Figure B.
5. Slide the shelf between the worksurface and the mounting plate in the gap formed by the washers as shown in Figure C. slide the shelf until the flanges on the front of the shelf find the first set of screws, locating the front edge of the shelf approx. 3/32" from the front edge of the table.

Figure C

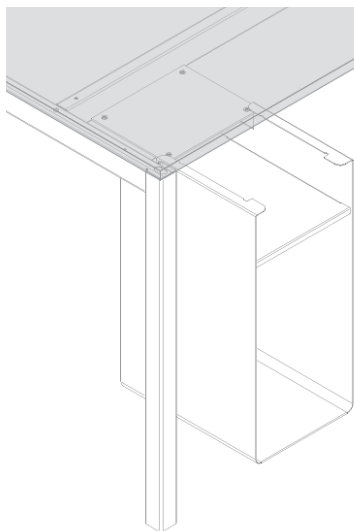

Figure A

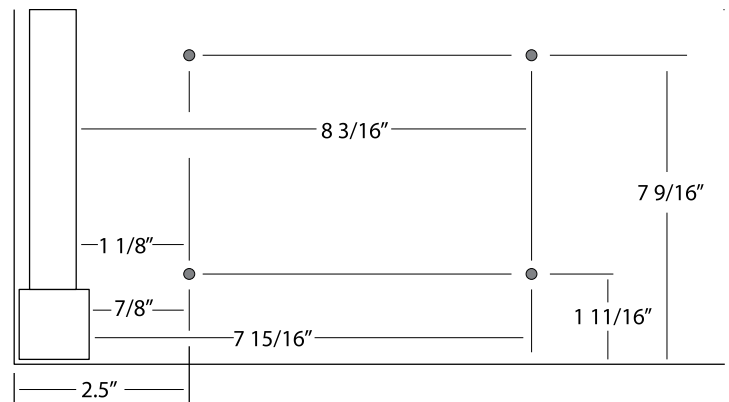
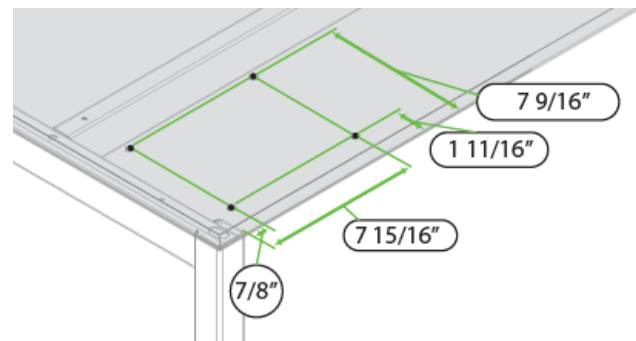

Figure B

