

Work Desk Frame

Tools Required

- Cordless driver with magnetic post and following tips
 - M 5 Hex Drive
 - 1/2" Deep Well Socket and Ratchet

Hardware Required (Included)

- 4— M10 Stem WITH 65mm Caster
- 4—M8-1.25 X 16 FLATHEAD CAP SCREWS
- 4—#10 X 5/8" PANHEAD PHILLIPS WOOD SCREW
- 2—#10 X 2" PANHEAD PHILLIPS WOOD SCREW

Installation

1. Unpack frame and hardware.
2. Install Flathead Cap Screws in Legs as shown in Figure A.
3. Install Caster Stems using 1/2" Deep Well Socket. Ensure stem is not cross threaded before tightening. Ensure stems are securely tightened before installing Caster.
4. Slide Horizontal Rails on the Welded Tabs of the Legs as shown in Figure B. Ensure there is no gap between Rail and the Leg.
5. Using the M5 Hex Drive, Turn the Cap Screws **COUNTER-CLOCKWISE**, backing the screws out until it presses firmly against the inside of the Horizontal Rail. See Figure B.
6. The provided Woodscrews will be used to attach the work-surfaces as seen in Figure C.

Figure A

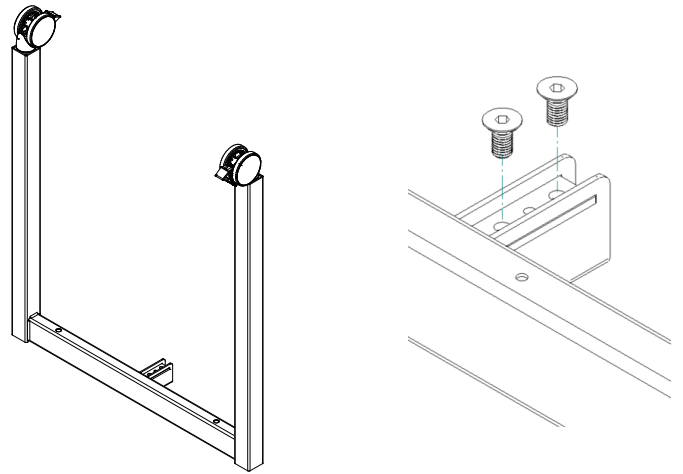

Figure B

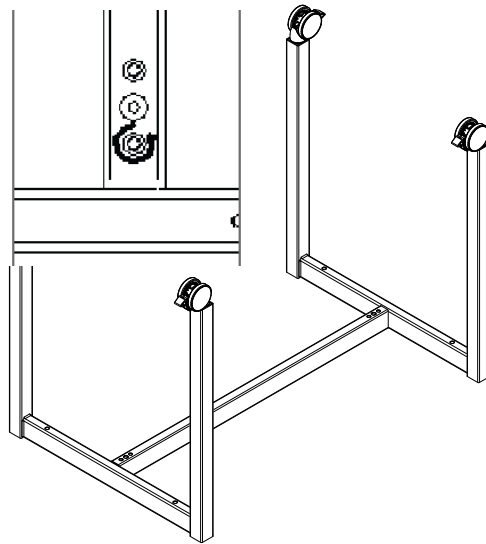

Figure C

