

## Assembly Instruction

**Note:** For better clarity, this Instruction does not always show the undersurface pedestal or other undersurface components.

1

Place the end support base in desired position on the underside of the upper worksurface. Attach with Sixteen (16) #12 x 7/8" Flat Head Screws (Figure A).

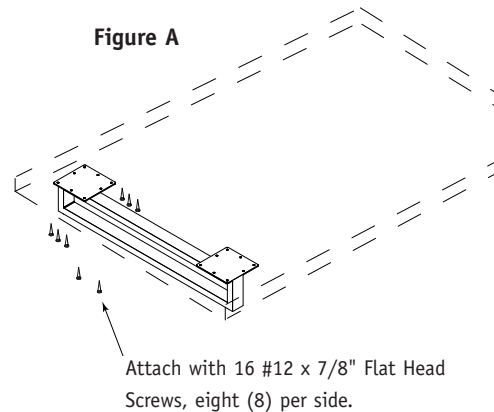

2

In the desired location, position the upper worksurface with the attached end support base placed on the lower unit.

**Note:** Place 2-3" wide masking tape where the end support base intersects with the lower unit. Using a pencil mark the location of the ends and sides of the end support base (Figure B).

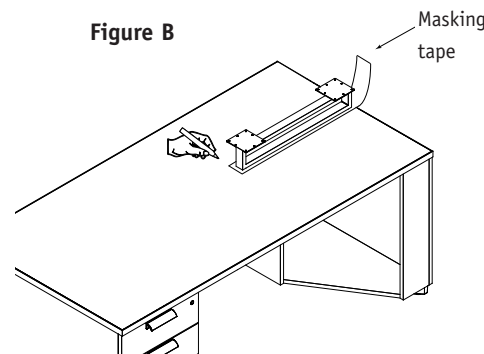

3

Using a tape measure and pencil mark the locations shown in (Figure C). for boring holes for two (2) 1/4-20 x 2 1/2" Flat Head Machine Screws.

Drill two (2) 5/16" holes through the lower worksurface.

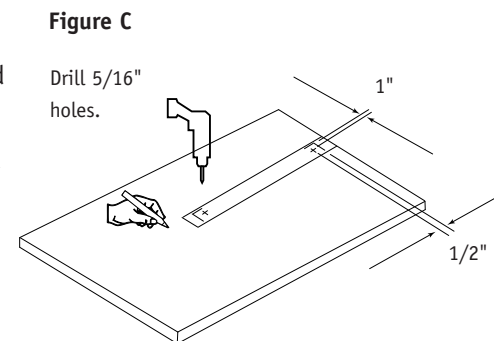

4

With the upper and lower units positioned in the desired locations, install two (2) 1/4-20 x 2 1/2" Flat Head Machine screws through the lower worksurface into the end support base (Figure D).

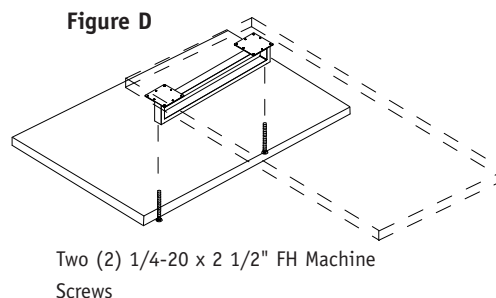

### End Support Base

#### Recommended Tools

- Drill with 5/16" bit
- Phillips head screwdriver
- Tape Measure
- 2-3" wide masking tape
- Pencil

#### Package Contents

	Qty.
• End Support Base	1
• #12 x 7/8" Flat Head Screw	16
• 1/4-20 x 2 1/2" Flat Head Machine Screw	2

# NATIONAL

Furniture with Personality®

Telephone 800.482.1717  
Fax 812.482.8800  
www.NationalOfficeFurniture.com

Part #2379236  
Rev,-

Printed in U.S.A  
© 2011 Kimball International, Inc.

Proper product installation, in accordance with these instructions, is the responsibility of the installing agent. If you have any questions concerning these instructions, please call National Customer Service 800.482.1717.