

Assembly Instruction

Note: This instruction will cover the assembly of the hardwire Alloy Adjustable Height Center Beam. If multiple units are to be ganged together complete the ganging kit assembly instructions (2892080) before proceeding.

- 1** With the center beam upside down. Remove both hardwire junction boxes from the center beam as shown in **Figure A**.

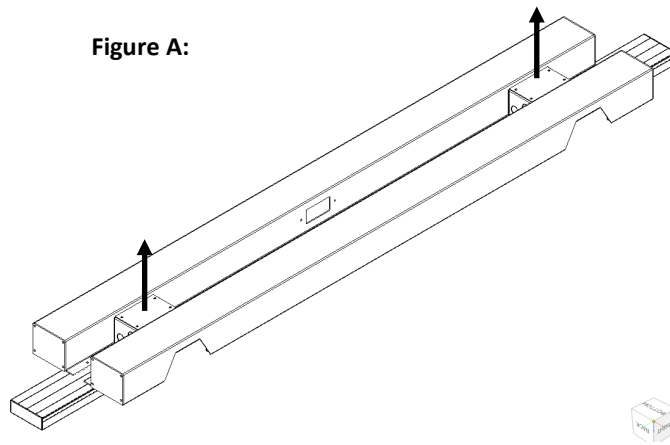

- 2** Remove the four screws securing one U-Channel to the center beam as shown in **Figure B**.

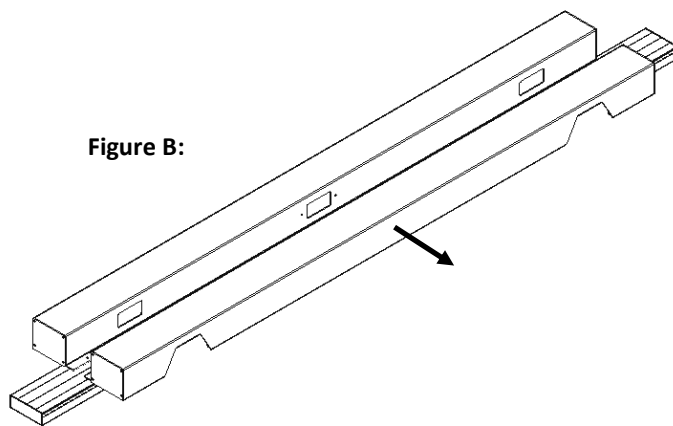

- 3** Have a licensed electrician wire and install the junction boxes on the center beam in the desired configuration. Re-install the U-Channel and junction box / cover in reverse order of steps 1 & 2.

Alloy Adjustable Height Center-Beam Hardwire

Package Contents

Hardware	Qty
Self Drilling Screws	4

Tools Required
Screw Driver
#2 Phillips Bit

NATIONAL

Furniture with Personality®

Telephone 800.482.1717
Fax 812.482.8800
www.NationalOfficeFurniture.com

Part # 2931594
Rev. -

Printed in U.S.A.
© 2014 Kimball International, Inc.

Proper product installation, in accordance with these instructions, is the responsibility of the installing agent. If you have any questions concerning these instructions, please call National Customer Service 800.482.1717.

Assembly Instruction

- 4** Place the beam between the crosslink tubes as shown in **Figure C**.

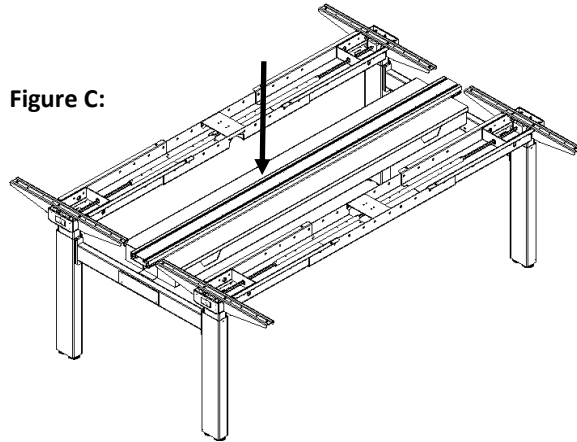

- 5** From the bottom of the beam align the v grooves with the four holes in the beam mounting brackets as shown in **Figure D**. Using the four provided self-drilling screws secure the beam to the crosslink tubes. Verify the beam is centered length wise between the crosslink tubes on both ends. It is recommended to use a clamp and pads when fastening the beam to help prevent misalignment.

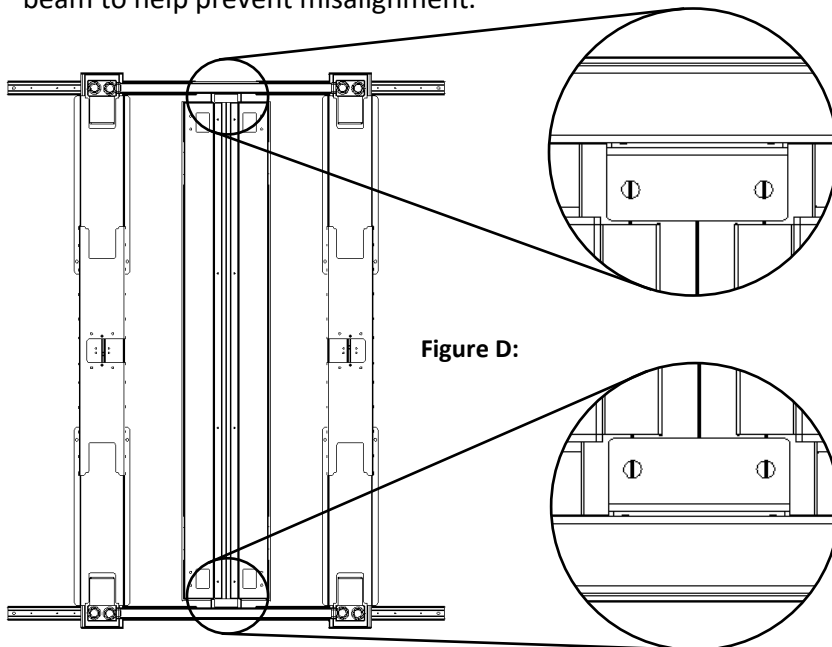

Proper product installation, in accordance with these instructions, is the responsibility of the installing agent. If you have any questions concerning these instructions, please call National Customer Service 800.482.1717.

Alloy
Adjustable Height
Center-Beam
Hardware

Package Contents

Hardware	Qty
Self Drilling Screws	4

Tools Required
Screw Driver
#2 Phillips Bit

NATIONAL
Furniture with Personality™

Telephone 800.482.1717
Fax 812.482.8800
www.NationalOfficeFurniture.com

Part # 2931594
Rev. -

Printed in U.S.A.
© 2014 Kimball International, Inc.