

Assembly Instruction

Note: This assembly instruction will cover all configurations of Alloy fixed height double bases.

- 1 Assemble the two adjustable upper channels as shown in **Figure A**. Using the supplied handle and lock plate roughly set the length of the adjustable channel to the desired surface size and configuration ordered in **Figure B**. **Do not fully tighten the lock plate.**

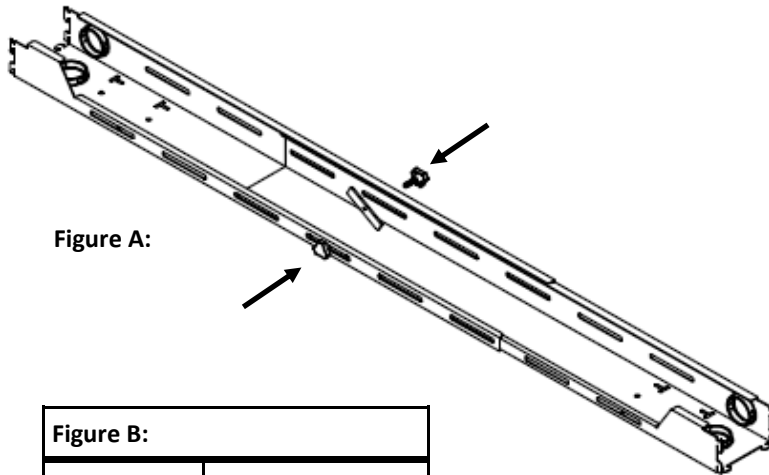

Figure A:

Figure B:	
Surface Size	Freestanding:
48	39 1/2"
54	45 1/2"
60	51 1/2"
66	57 1/2"
72	63 1/2"

- 2 Using the tabs as shown in **Figure C**, attach one side of the adjustable upper channel to the first end leg.

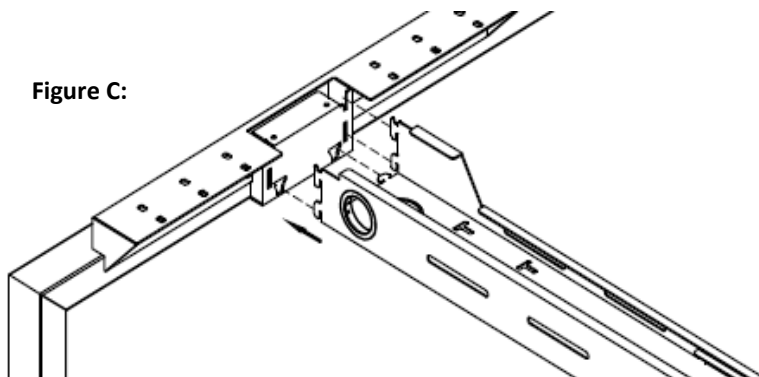

Figure C:

Alloy Fixed Height Single Bases

Package Contents

Hardware	Qty
M6 x 12	4
Handle	2
Lock Plate	2
Mounting Bracket	2
Woodscrews	4

Tools Required

4mm Allen Wrench
Screw Driver
#2 Phillips Bit

NATIONAL

Furniture with Personality™

Telephone 800.482.1717
Fax 812.482.8800
www.NationalOfficeFurniture.com

Part # 2951092
Rev. -

Printed in U.S.A.
© 2014 Kimball International, Inc.

Proper product installation, in accordance with these instructions, is the responsibility of the installing agent. If you have any questions concerning these instructions, please call National Customer Service 800.482.1717.

Assembly Instruction

- 3** Verify the upper channel is fully seated as shown in **Figure D**. Using the mounting bracket and M6 x 12 screws provided, secure the adjustable upper channel to the end leg as shown in **Figure E**.

Figure D:

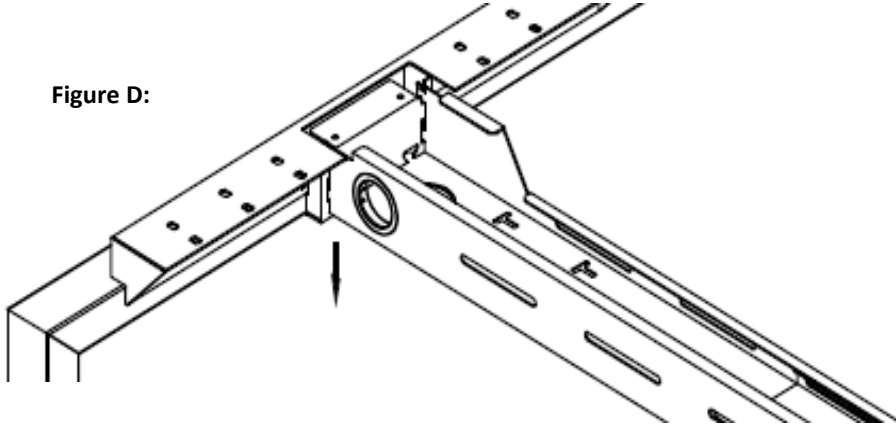
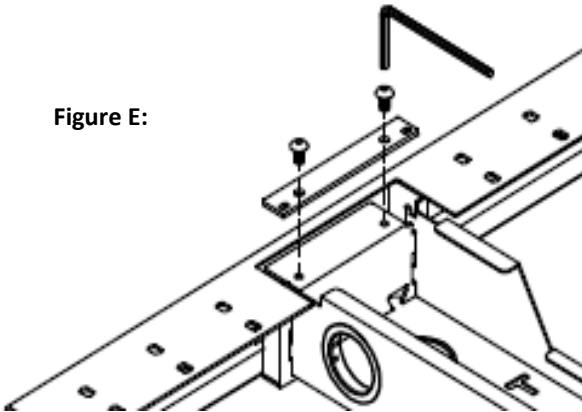

Figure E:



- 4** Repeat steps 2-3 to secure the opposite end leg. Once complete, the entire frame should be constructed to your desired configuration.

Alloy Fixed Height Single Bases

Package Contents

Hardware	Qty
M6 x 12	4
Handle	2
Lock Plate	2
Mounting Bracket	2
Woodscrews	4

Tools Required

4mm Allen Wrench
Screw Driver
#2 Phillips Bit

NATIONAL

Furniture with Personality®

Telephone 800.482.1717
Fax 812.482.8800
www.NationalOfficeFurniture.com

Part # 2951092
Rev. -

Printed in U.S.A.
© 2014 Kimball International, Inc.

Proper product installation, in accordance with these instructions, is the responsibility of the installing agent. If you have any questions concerning these instructions, please call National Customer Service 800.482.1717.

Assembly Instruction

Alloy Fixed Height Single Bases

- 5** Attach the worksurfaces to **one end** of the frame using the provided wood-screws. Center the worksurface width wise on the end leg. Reference the dimension in **Figure F** for location of the surface length wise.

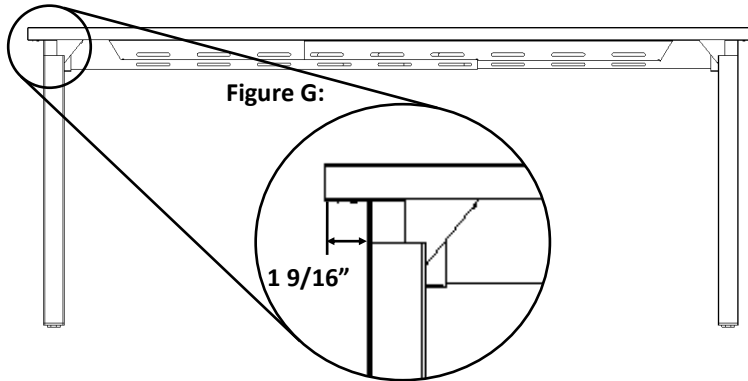

- 6** Pull the adjustable upper channels / frame into final position. Secure the final end leg to the surface using the dimensions shown in **Figure G**.

- 7** Once the surface is secured. Fully tighten down the handle and lock plates from Step 1 on the adjustable upper channel.

Package Contents

Hardware	Qty
M6 x 12	4
Handle	2
Lock Plate	2
Mounting Bracket	2
Woodscrews	4

Tools Required

4mm Allen Wrench
Screw Driver
#2 Phillips Bit

NATIONAL

Furniture with Personality®

Telephone 800.482.1717
Fax 812.482.8800
www.NationalOfficeFurniture.com

Part # 2951092
Rev. -

Printed in U.S.A
© 2014 Kimball International, Inc.

Proper product installation, in accordance with these instructions, is the responsibility of the installing agent. If you have any questions concerning these instructions, please call National Customer Service 800.482.1717.