

## Assembly Instruction

**Note:** This assembly instruction will cover all configurations of Alloy adjustable height double bases.

- 1** Screw in the provided adjustable glides into each leg as shown in **Figure A**. Two glides per leg.

Figure A:

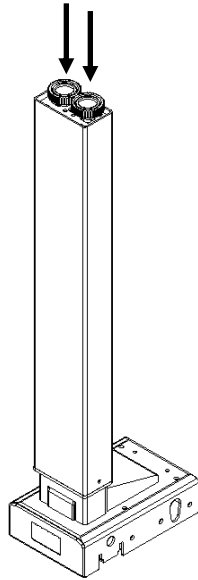

- 2** Partially screw four of the provided M8 x 16 screws into the holes on both legs as shown in **Figure B**.

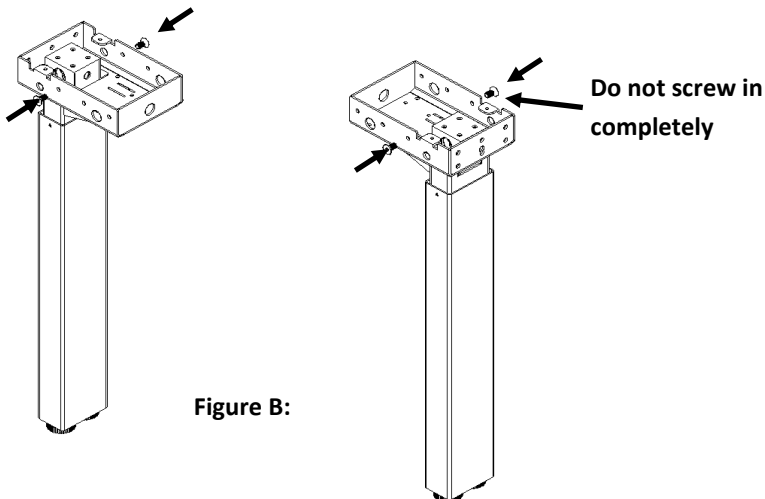

Figure B:

### Alloy Adjustable Height Double Bases

#### Package Contents

| Hardware           | Qty |
|--------------------|-----|
| M8 x 16 Screw      | 20  |
| M8 Nut             | 8   |
| M8 x 12 Screw      | 8   |
| M6 x 12 Screw      | 4   |
| M5 x 12 Screw      | 4   |
| Bumper 25mm        | 4   |
| Bumper 17mm        | 4   |
| Self Driving Screw | 6   |
| Spanner Tool       | 1   |
| Wood Screw         | 8   |

#### Tools Required

3mm Allen Wrench  
4mm Allen Wrench  
5mm Allen Wrench  
Screw Driver  
#2 Phillips Driver  
#3 Phillips Driver

# NATIONAL

Furniture with Personality®

Telephone 800.482.1717  
Fax 812.482.8800  
[www.NationalOfficeFurniture.com](http://www.NationalOfficeFurniture.com)

Part # 3024216  
Rev. -

Printed in U.S.A.  
© 2014 Kimball International, Inc.

Proper product installation, in accordance with these instructions, is the responsibility of the installing agent. If you have any questions concerning these instructions, please call National Customer Service 800.482.1717.

## Assembly Instruction

**3**

Assemble the upper channel as shown in **Figure C**, using the supplied M8 x 16 screws and M8 Nuts. Reference the chart in **Figure D** to size overall upper channel for surface size ordered. Four holes on each side will align to assemble the adjustable upper channel. **Verify that a quantity of (8) M8 x 16 screws are used to fasten the adjustable upper channel together-**

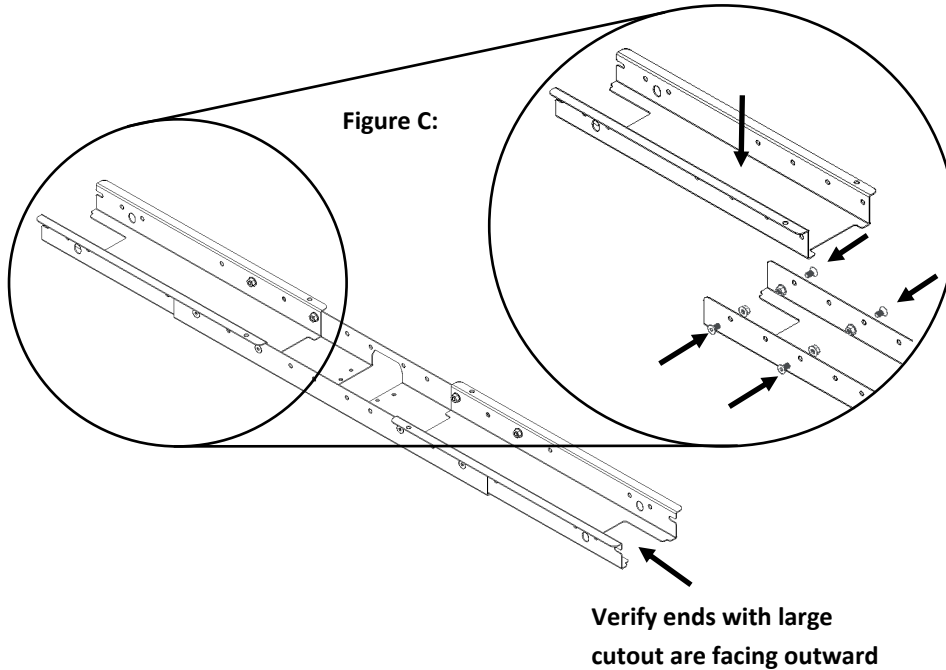

| <b>Figure D:</b> |   |
|------------------|---|
| Surface Size     | Adjustable Channel Overall Approximate Length |
| 48               | 37 7/8"                                       |
| 54               | 43 7/8"                                       |
| 60               | 49 7/8"                                       |
| 66               | 55 7/8"                                       |
| 72               | 61 7/8"                                       |

### Alloy Adjustable Height Double Bases

#### Package Contents

| Hardware           | Qty |
|--------------------|-----|
| M8 x 16 Screw      | 20  |
| M8 Nut             | 8   |
| M8 x 12 Screw      | 8   |
| M6 x 12 Screw      | 4   |
| M5 x 12 Screw      | 4   |
| Bumper 25mm        | 4   |
| Bumper 17mm        | 4   |
| Self Driving Screw | 6   |
| Spanner Tool       | 1   |
| Wood Screw         | 8   |

#### Tools Required

- 3mm Allen Wrench
- 4mm Allen Wrench
- 5mm Allen Wrench
- Screw Driver
- #2 Phillips Driver
- #3 Phillips Driver

# NATIONAL

Furniture with Personality<sup>®</sup>

Telephone 800.482.1717  
 Fax 812.482.8800  
[www.NationalOfficeFurniture.com](http://www.NationalOfficeFurniture.com)

Part # 3024216  
 Rev. -

Printed in U.S.A  
 © 2014 Kimball International, Inc.

Proper product installation, in accordance with these instructions, is the responsibility of the installing agent. If you have any questions concerning these instructions, please call National Customer Service 800.482.1717.

## Assembly Instruction

- 4** Verify that crosslink mounting plate and the motor cutout are orientated in the same direction of each other as shown in Figure E. The motor cutout and crosslink mounting plates must face away from the user.

Attach the adjustable upper channel (Set to the correct length) to both legs as shown in **Figure F**. Screw in the additional (4) screws to prevent the upper channel from pivoting on the legs. Now, fully Tighten the (4) screws threaded in partially from Step 1.

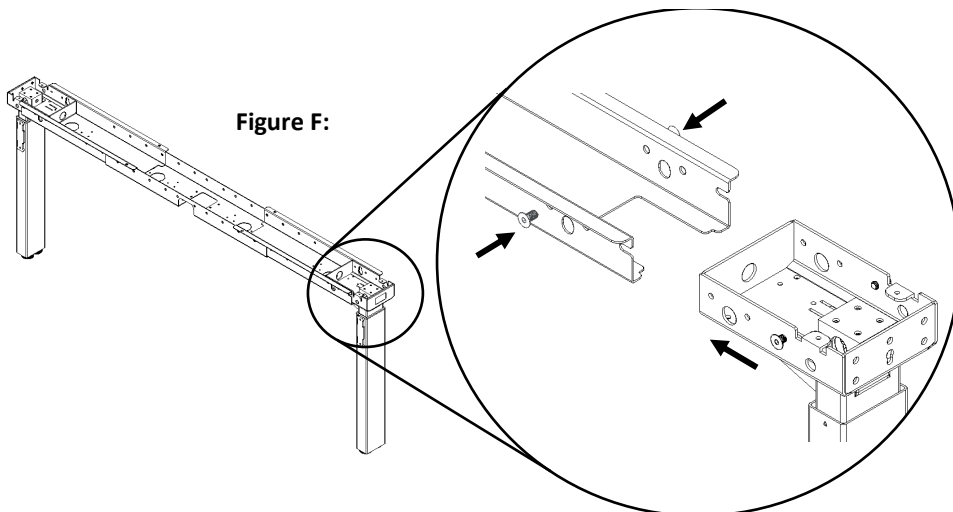
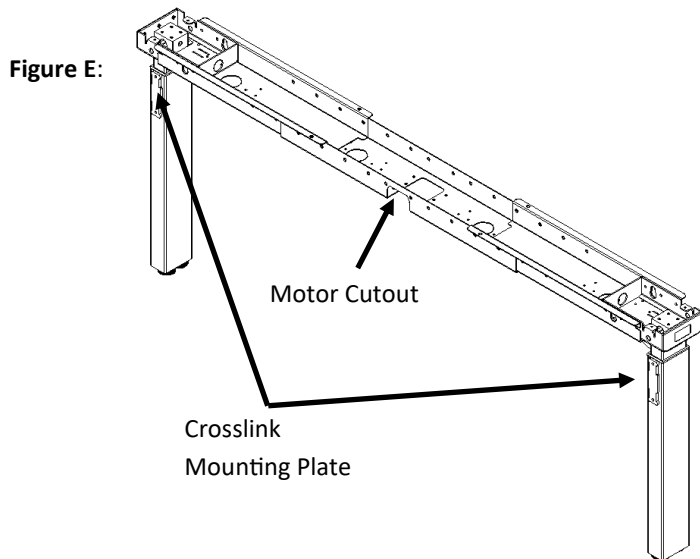

**Verify upper channel is in the correct orientation as described in step 4 before proceeding.** Failure to orient the upper channel correctly will cause the adjustable height mechanism to work in the reverse direction.

Proper product installation, in accordance with these instructions, is the responsibility of the installing agent. If you have any questions concerning these instructions, please call National Customer Service 800.482.1717.

### Alloy

### Adjustable Height Double Bases

### Package Contents

| Hardware           | Qty |
|--------------------|-----|
| M8 x 16 Screw      | 20  |
| M8 Nut             | 8   |
| M8 x 12 Screw      | 8   |
| M6 x 12 Screw      | 4   |
| M5 x 12 Screw      | 4   |
| Bumper 25mm        | 4   |
| Bumper 17mm        | 4   |
| Self Driving Screw | 6   |
| Spanner Tool       | 1   |
| Wood Screw         | 8   |

### Tools Required

3mm Allen Wrench  
4mm Allen Wrench  
5mm Allen Wrench  
Screw Driver  
#2 Phillips Driver  
#3 Phillips Driver

# NATIONAL

Furniture with Personality<sup>®</sup>

Telephone 800.482.1717  
Fax 812.482.8800  
[www.NationalOfficeFurniture.com](http://www.NationalOfficeFurniture.com)

Part # 3024216  
Rev. -

Printed in U.S.A  
© 2014 Kimball International, Inc.

## Assembly Instruction

5

Repeat steps 1—5 on the second height adjustable base frame. Now, attach the crosslink tubes to one side of the height adjustable base as shown in **Figure G**, using the provided screws. **Verify the crosslink tube is oriented with the mounting bracket towards the center as shown in Figure G.** Once the first side is secured repeat to attach the second height adjustable frame to the crosslink tubes. The frame should now be able to stand on its own. Place the **crosslink covers** on both ends of each crosslink tube to hide all mounting hardware.

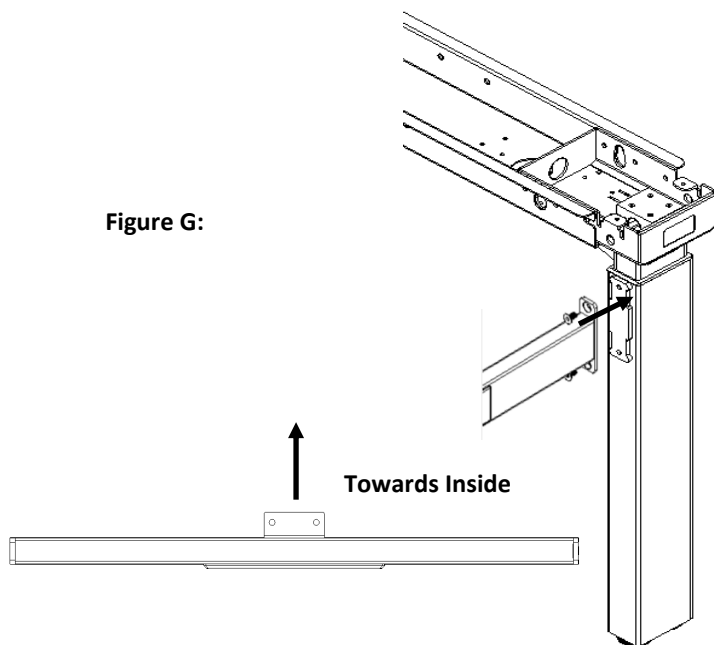

6

Secure the motor mount using the remaining four M8 x 16 screws as shown in **Figure H**.

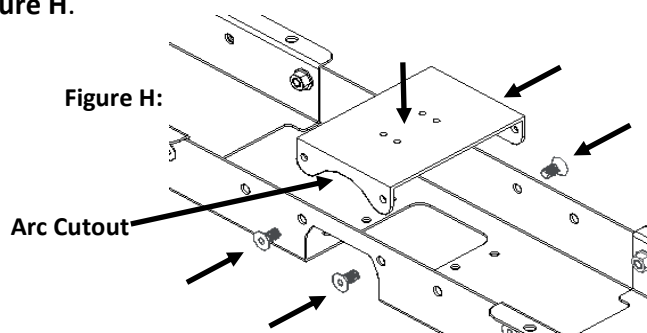

**Note: Verify that the motor mount plate is oriented the same as in Figure G. The arc cutout must be facing away from the user.**

Proper product installation, in accordance with these instructions, is the responsibility of the installing agent. If you have any questions concerning these instructions, please call National Customer Service 800.482.1717.

### Alloy Adjustable Height Double Bases

#### Package Contents

| Hardware           | Qty |
|--------------------|-----|
| M8 x 16 Screw      | 20  |
| M8 Nut             | 8   |
| M8 x 12 Screw      | 8   |
| M6 x 12 Screw      | 4   |
| M5 x 12 Screw      | 4   |
| Bumper 25mm        | 4   |
| Bumper 17mm        | 4   |
| Self Driving Screw | 6   |
| Spanner Tool       | 1   |
| Wood Screw         | 8   |

#### Tools Required

3mm Allen Wrench  
4mm Allen Wrench  
5mm Allen Wrench  
Screw Driver  
#2 Phillips Driver  
#3 Phillips Driver

# NATIONAL

Furniture with Personality™

Telephone 800.482.1717  
Fax 812.482.8800  
[www.NationalOfficeFurniture.com](http://www.NationalOfficeFurniture.com)

Part # 3024216  
Rev. -

Printed in U.S.A.  
© 2014 Kimball International, Inc.

## Assembly Instruction

### Alloy Adjustable Height Double Bases

- 7** Attach the motor to the motor mount using the supplied M5 x 12 screws as shown in **Figure J**.

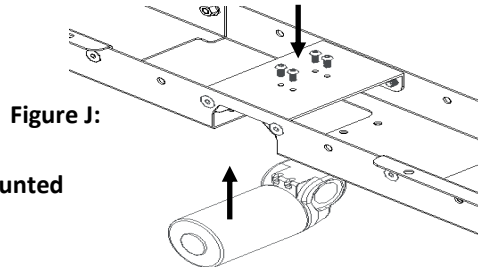

Figure J:



**Motor must be mounted  
away from user.**

- 8** Remove plastic undersurface support arm covers and attach the two undersurface support arms using the supplied M6 x 12 screws as shown in **Figure K**. **Do not re-attach plastic undersurface support arm covers until after worksurface has been secured.**

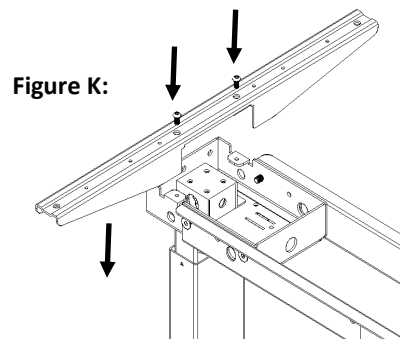

Figure K:

- 9** Attach the leg end caps, 1" (25mm) bumpers, and 5/8" (17mm) bumpers as shown in **Figure L**. Bumpers are used to even out worksurface installation.

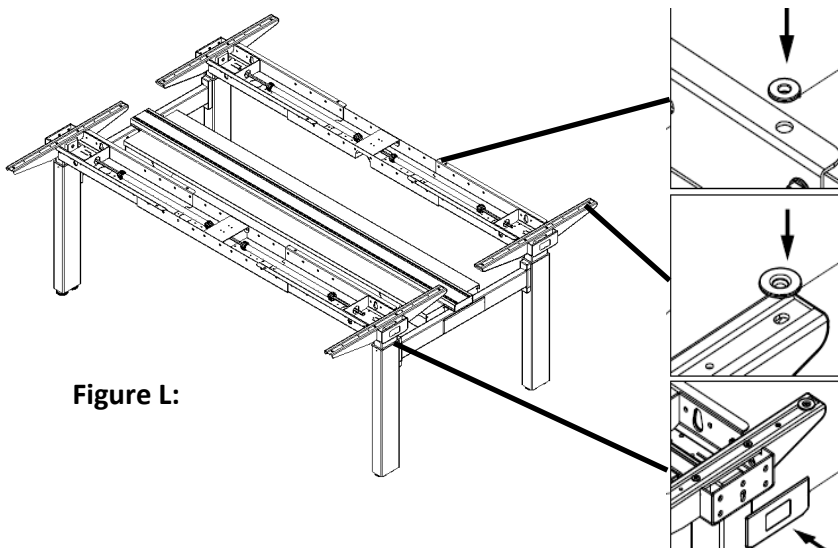

Figure L:

### Package Contents

| Hardware           | Qty |
|--------------------|-----|
| M8 x 16 Screw      | 20  |
| M8 Nut             | 8   |
| M8 x 12 Screw      | 8   |
| M6 x 12 Screw      | 4   |
| M5 x 12 Screw      | 4   |
| Bumper 25mm        | 4   |
| Bumper 17mm        | 4   |
| Self Driving Screw | 6   |
| Spanner Tool       | 1   |
| Wood Screw         | 8   |

### Tools Required

3mm Allen Wrench  
4mm Allen Wrench  
5mm Allen Wrench  
Screw Driver  
#2 Phillips Driver  
#3 Phillips Driver

# NATIONAL

Furniture with Personality™

Telephone 800.482.1717  
Fax 812.482.8800  
[www.NationalOfficeFurniture.com](http://www.NationalOfficeFurniture.com)

Part # 3024216  
Rev. -

Printed in U.S.A  
© 2014 Kimball International, Inc.

Proper product installation, in accordance with these instructions, is the responsibility of the installing agent. If you have any questions concerning these instructions, please call National Customer Service 800.482.1717.

## Assembly Instruction

- 10** Verify the motor is facing away from the user. Insert the hex drive rods through the motor and into each leg. Use the spanner tool provided to align the rods as shown in **Figure M**. When all drive rods are inserted and aligned use the opposite end of the spanner tool to tighten the end caps. **Verify that hex rod completely extends through each leg, and overlaps a minimum of 1 1/2" into the aluminum coupler on each end.**

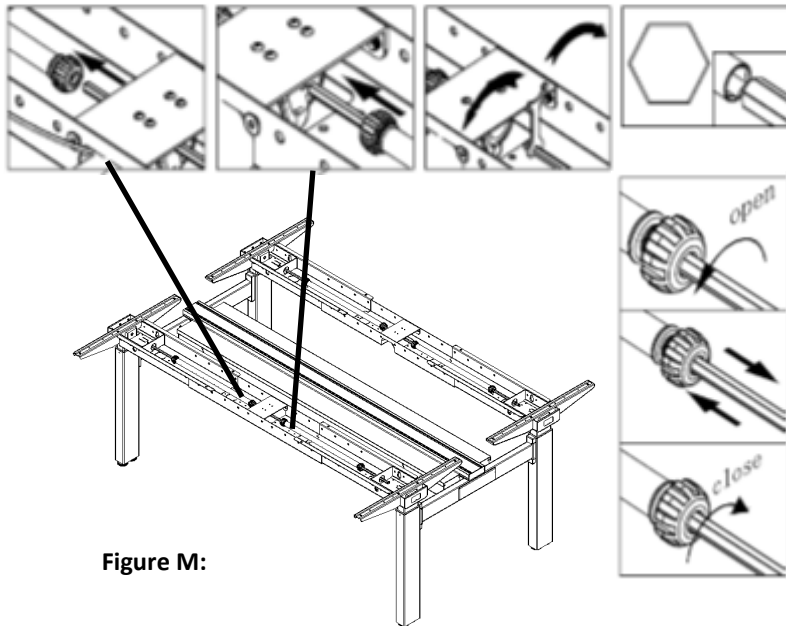

Figure M:



**Securely tighten all of the hex rod connections with the spanner tool before testing**

- 11** Temporarily connect the control box and control pad to the motor to test the unit. **Follow the set up directions included with the control box exactly.** When complete, disconnect the control box / control pad and proceed to the next step.

**Note:** If ganging two units together complete the ganging kit assembly instructions (2892080) before proceeding.

Proper product installation, in accordance with these instructions, is the responsibility of the installing agent. If you have any questions concerning these instructions, please call National Customer Service 800.482.1717.

### Alloy

### Adjustable Height Double Bases

### Package Contents

| Hardware           | Qty |
|--------------------|-----|
| M8 x 16 Screw      | 20  |
| M8 Nut             | 8   |
| M8 x 12 Screw      | 8   |
| M6 x 12 Screw      | 4   |
| M5 x 12 Screw      | 4   |
| Bumper 25mm        | 4   |
| Bumper 17mm        | 4   |
| Self Driving Screw | 6   |
| Spanner Tool       | 1   |
| Wood Screw         | 8   |

### Tools Required

3mm Allen Wrench  
4mm Allen Wrench  
5mm Allen Wrench  
Screw Driver  
#2 Phillips Driver  
#3 Phillips Driver

# NATIONAL

Furniture with Personality®

Telephone 800.482.1717  
Fax 812.482.8800  
[www.NationalOfficeFurniture.com](http://www.NationalOfficeFurniture.com)

Part # 3024216  
Rev. -

Printed in U.S.A  
© 2014 Kimball International, Inc.

## Assembly Instruction

- 12** Place the beam between the crosslink tubes as shown in **Figure N**. Non powered and powered beams are installed in the same method.

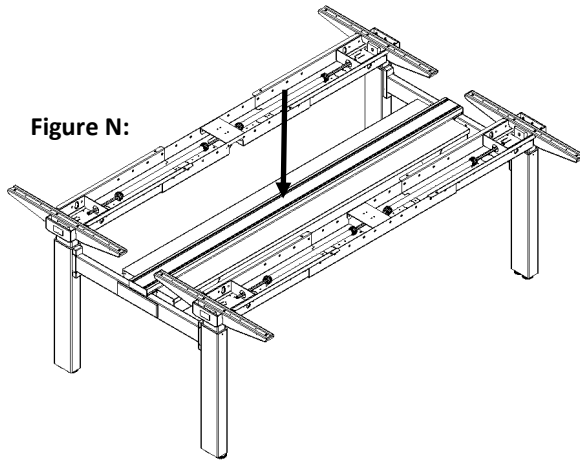

- 13** From the bottom of the beam align the two outside v grooves with the four holes in the beam mounting brackets as shown in **Figure O**. Using the four provided self-drilling screws secure the beam to the crosslink tubes. Verify the beam is centered length wise between the crosslink tubes on both ends. It is recommended to use a clamp and pads when fastening the beam to help prevent misalignment.

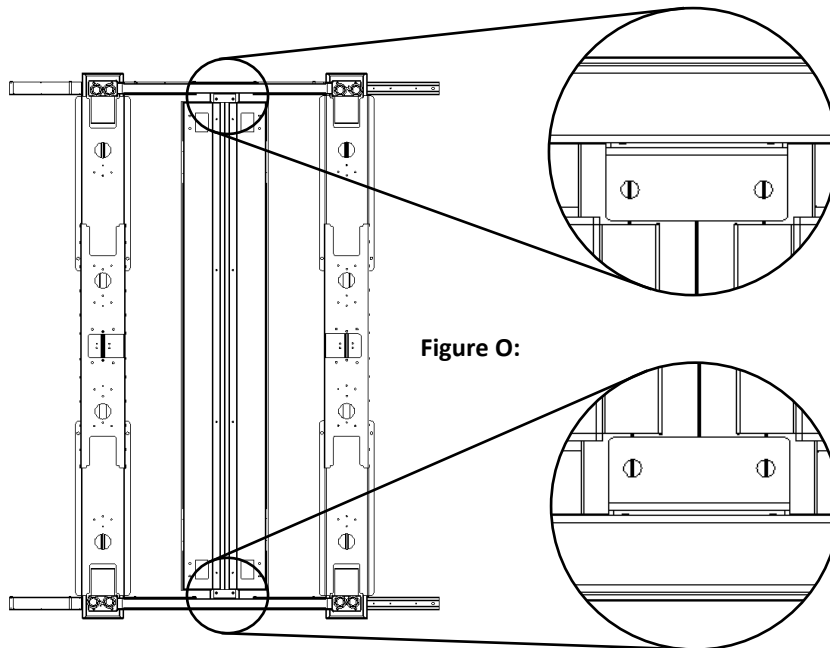

### Alloy Adjustable Height Double Bases

#### Package Contents

| Hardware           | Qty |
|--------------------|-----|
| M8 x 16 Screw      | 20  |
| M8 Nut             | 8   |
| M8 x 12 Screw      | 8   |
| M6 x 12 Screw      | 4   |
| M5 x 12 Screw      | 4   |
| Bumper 25mm        | 4   |
| Bumper 17mm        | 4   |
| Self Driving Screw | 6   |
| Spanner Tool       | 1   |
| Wood Screw         | 8   |

#### Tools Required

3mm Allen Wrench  
4mm Allen Wrench  
5mm Allen Wrench  
Screw Driver  
#2 Phillips Driver  
#3 Phillips Driver

# NATIONAL

Furniture with Personality™

Telephone 800.482.1717  
Fax 812.482.8800  
[www.NationalOfficeFurniture.com](http://www.NationalOfficeFurniture.com)

Part # 3024216  
Rev. -

Printed in U.S.A  
© 2014 Kimball International, Inc.

Proper product installation, in accordance with these instructions, is the responsibility of the installing agent. If you have any questions concerning these instructions, please call National Customer Service 800.482.1717.

## Assembly Instruction

- 14** Attach all worksurfaces to the frames using the provided screws as shown in **Figure P**. Align the surfaces with the four pre-drilled holes in the surface. Also drive the four reaming screws into the holes. Re-attach the plastic end support arm covers after all screws have been

**Figure P:**

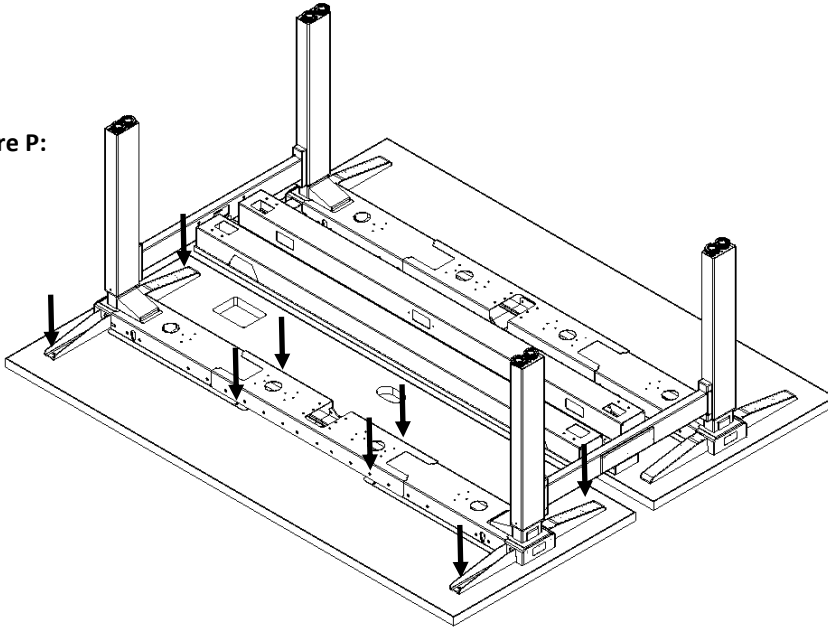

- 15** Attach the control box and control pad to the **underside** of the work-surface as shown in **Figure Q**. Repeat the step for all worksurfaces to be assembled.

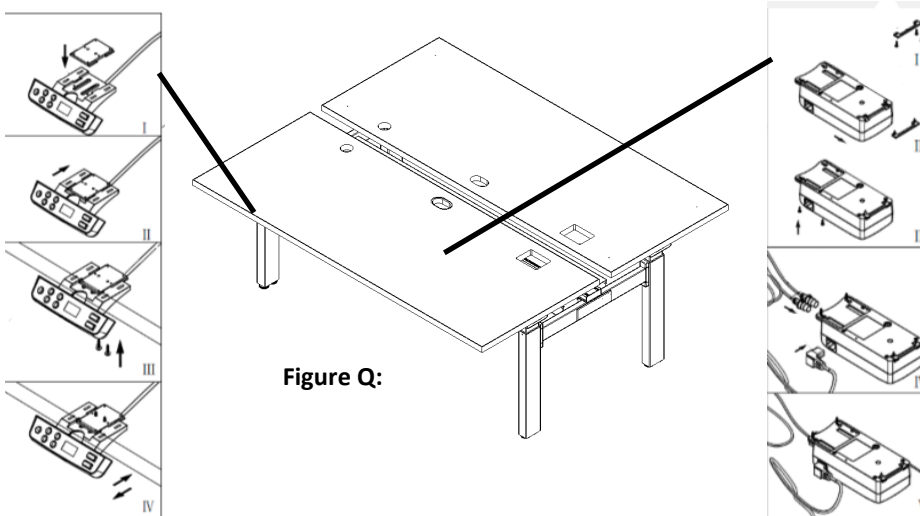

**Figure Q:**

### Alloy Adjustable Height Double Bases

#### Package Contents

| Hardware           | Qty |
|--------------------|-----|
| M8 x 16 Screw      | 20  |
| M8 Nut             | 8   |
| M8 x 12 Screw      | 8   |
| M6 x 12 Screw      | 4   |
| M5 x 12 Screw      | 4   |
| Bumper 25mm        | 4   |
| Bumper 17mm        | 4   |
| Self Driving Screw | 6   |
| Spanner Tool       | 1   |
| Wood Screw         | 8   |

#### Tools Required

3mm Allen Wrench  
4mm Allen Wrench  
5mm Allen Wrench  
Screw Driver  
#2 Phillips Driver  
#3 Phillips Driver

# NATIONAL

Furniture with Personality™

Telephone 800.482.1717  
Fax 812.482.8800  
[www.NationalOfficeFurniture.com](http://www.NationalOfficeFurniture.com)

Part # 3024216  
Rev. -

Printed in U.S.A  
© 2014 Kimball International, Inc.

Proper product installation, in accordance with these instructions, is the responsibility of the installing agent. If you have any questions concerning these instructions, please call National Customer Service 800.482.1717.