

Assembly Instruction

Note: This assembly instruction will cover all configurations of Alloy adjustable height single bases.

- 1 With the leg upside down. Attach the freestanding foot to the bottom of the adjustable height leg using the four provided M8x20 screws as shown in **Figure A**. Repeat for the second foot.

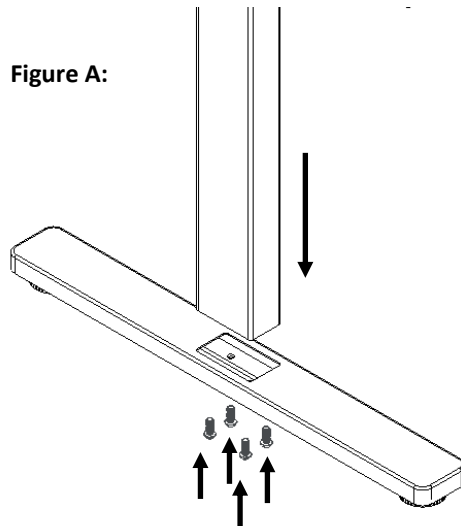

- 2 Partially screw four of the provided M8 x 16 screws into the holes on both legs as shown in **Figure B**.

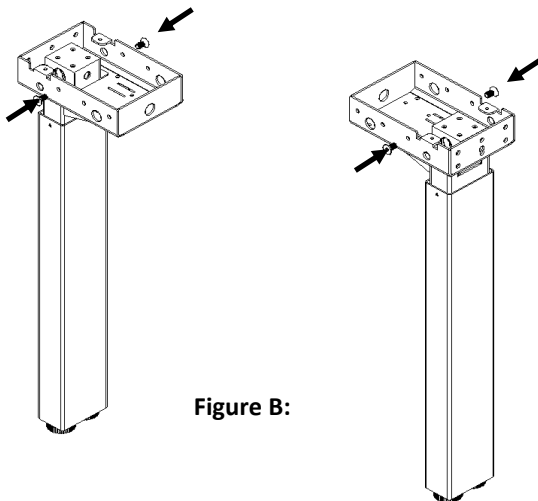

Alloy Adjustable Height Single Bases

Package Contents

Hardware	Qty
M8 x 16 Screw	20
M8 Nut	8
M8 x 12 Screw	8
M6 x 12 Screw	4
M5 x 12 Screw	4
Bumper 25mm	4
Bumper 17mm	4
Self Driving Screw	6
Spanner Tool	1

Tools Required

3mm Allen Wrench
4mm Allen Wrench
5mm Allen Wrench
Screw Driver
#2 Phillips Driver

NATIONAL

Furniture with Personality™

Telephone 800.482.1717
Fax 812.482.8800
www.NationalOfficeFurniture.com

Part # 3024217
Rev. -

Printed in U.S.A
© 2014 Kimball International, Inc.

Proper product installation, in accordance with these instructions, is the responsibility of the installing agent. If you have any questions concerning these instructions, please call National Customer Service 800.482.1717.

Assembly Instruction

3

Assemble the upper channel as shown in **Figure C**, using the supplied M8 x 16 screws and M8 Nuts. Reference the chart in **Figure D** to size overall upper channel for desired surface size. Verify that a quantity of (8) M8 x 16 screws are used to fasten each adjustable upper channel together.

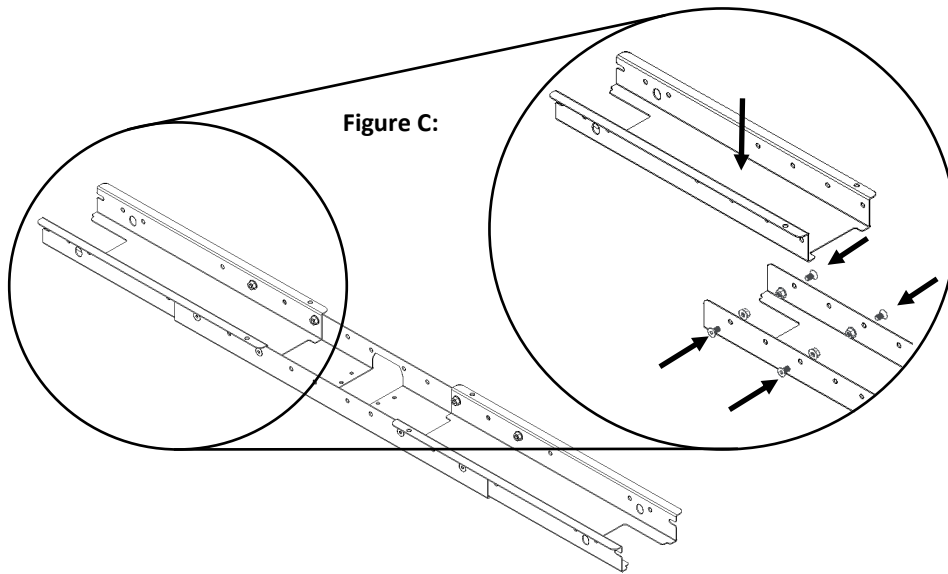

Figure D:	
Surface Size	Adjustable Channel Overall Approximate Length
48	37 7/8"
54	43 7/8"
60	49 7/8"
66	55 7/8"
72	61 7/8"

Alloy
Adjustable Height Single
Bases

Package Contents

Hardware	Qty
M8 x 16 Screw	20
M8 Nut	8
M8 x 12 Screw	8
M6 x 12 Screw	4
M5 x 12 Screw	4
Bumper 25mm	4
Bumper 17mm	4
Self Driving Screw	6
Spanner Tool	1

Tools Required

3mm Allen Wrench
4mm Allen Wrench
5mm Allen Wrench
Screw Driver
#2 Phillips Driver

NATIONAL

Furniture with Personality™

Telephone 800.482.1717
Fax 812.482.8800
www.NationalOfficeFurniture.com

Part # 3024217
Rev. -

Printed in U.S.A.
© 2014 Kimball International, Inc.

Proper product installation, in accordance with these instructions, is the responsibility of the installing agent. If you have any questions concerning these instructions, please call National Customer Service 800.482.1717.

Assembly Instruction

Alloy Adjustable Height Single Bases

- 4** Attach the adjustable upper channel (Set to the correct length) to both legs as shown in **Figure E**. Fully Tighten the (4) screws partially started in Step 1.

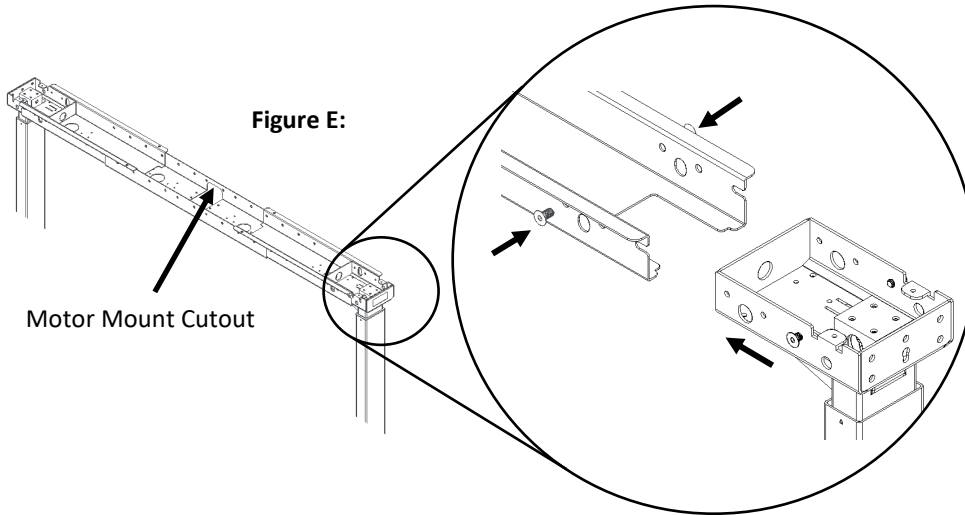

Note: Verify that the leg labeled with an R is on the right side of the user and the leg labeled with an L is on the left side of the user. The motor mount cutout must be oriented away from the user as shown above.

- 5** Secure the motor mount using the remaining four M8 x 16 screws as shown in **Figure F**.

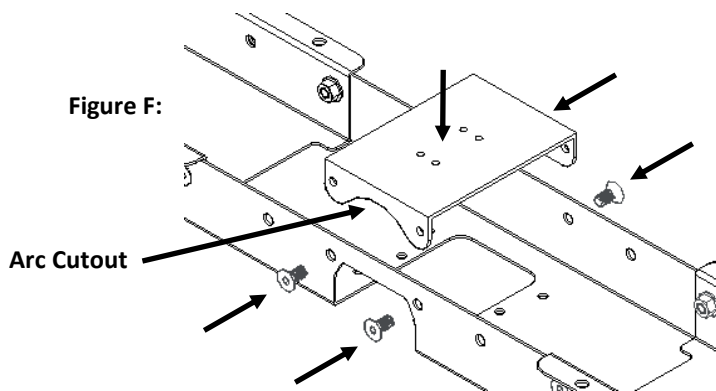

Note: Verify that the motor mount plate is oriented the same as in **Figure G**. The arc cutout must be facing away from the user.

Package Contents

Hardware	Qty
M8 x 16 Screw	20
M8 Nut	8
M8 x 12 Screw	8
M6 x 12 Screw	4
M5 x 12 Screw	4
Bumper 25mm	4
Bumper 17mm	4
Self Driving Screw	6
Spanner Tool	1
Wood Screw	8

Tools Required

3mm Allen Wrench
4mm Allen Wrench
5mm Allen Wrench
Screw Driver
#2 Phillips Driver

NATIONAL

Furniture with Personality™

Telephone 800.482.1717
Fax 812.482.8800
www.NationalOfficeFurniture.com

Part # 3024217
Rev, -

Printed in U.S.A
© 2014 Kimball International, Inc.

Proper product installation, in accordance with these instructions, is the responsibility of the installing agent. If you have any questions concerning these instructions, please call National Customer Service 800.482.1717.

Assembly Instruction

Alloy Adjustable Height Single Bases

- 6** Attach the motor to the motor mount using the supplied M5 x 12 screws as shown in **Figure G**. **Motor must face away from user.**

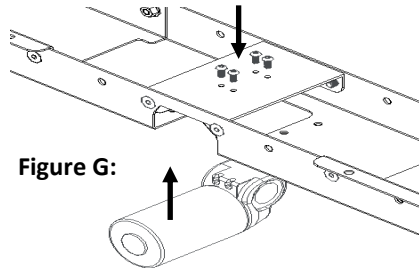

- 7** Remove plastic undersurface support arm covers and attach the two undersurface support arms using the supplied M6 x 12 screws as shown in **Figure H**. **Do not re-attach plastic undersurface support arm covers until after worksurface has been secured.**

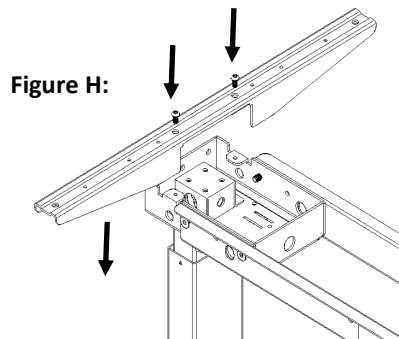

- 8** Attach the leg end caps, 1" (25mm) bumpers, and 5/8" (17mm) bumpers as shown in **Figure J**.

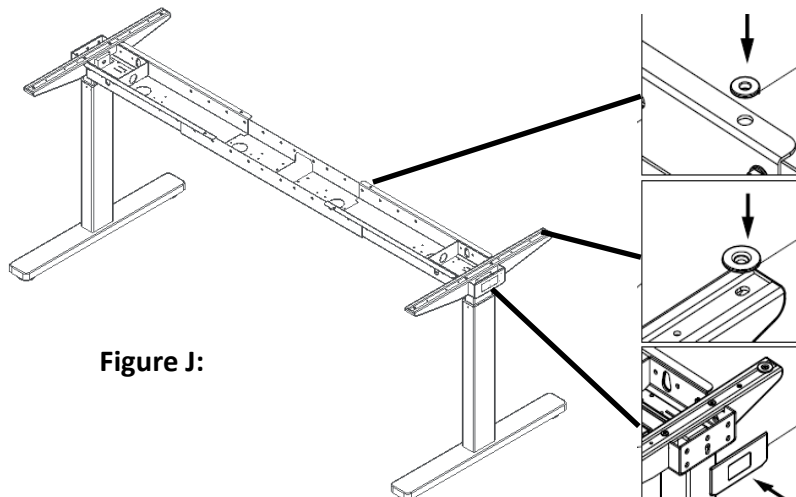

Package Contents

Hardware	Qty
M8 x 16 Screw	20
M8 Nut	8
M8 x 12 Screw	8
M6 x 12 Screw	4
M5 x 12 Screw	4
Bumper 25mm	4
Bumper 17mm	4
Self Driving Screw	6
Spanner Tool	1
Wood Screw	8

Tools Required

3mm Allen Wrench
4mm Allen Wrench
5mm Allen Wrench
Screw Driver
#2 Phillips Driver

NATIONAL

Furniture with Personality™

Telephone 800.482.1717
Fax 812.482.8800
www.NationalOfficeFurniture.com

Part # 3024217
Rev. -

Printed in U.S.A.
© 2014 Kimball International, Inc.

Proper product installation, in accordance with these instructions, is the responsibility of the installing agent. If you have any questions concerning these instructions, please call National Customer Service 800.482.1717.

Assembly Instruction

- 9** Verify the motor is facing away from the user. Insert the hex drive rods through the motor and into each leg. Use the spanner tool provided to align the rods as shown in **Figure K**. When all drive rods are inserted and aligned use the opposite end of the spanner tool to tighten the end caps. **Verify that hex rod completely extends through each leg, and overlaps a minimum of 1 1/2" into the aluminum coupler on each end.**

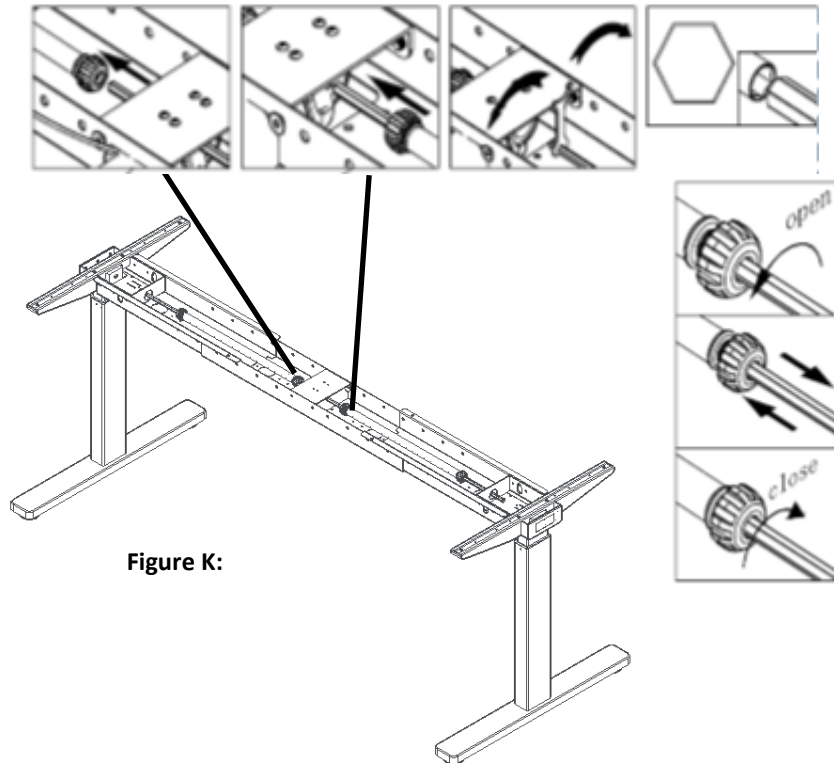

Figure K:



Securely tighten all of the hex rod connections with the spanner tool before testing

10

Temporarily connect the control box and control pad to the motor to test the unit. **Follow the set up directions included with the control box exactly.** When complete, disconnect the control box / control pad and proceed to the next step.

Proper product installation, in accordance with these instructions, is the responsibility of the installing agent. If you have any questions concerning these instructions, please call National Customer Service 800.482.1717.

Alloy

Adjustable Height Single Bases

Package Contents

Hardware	Qty
M8 x 16 Screw	20
M8 Nut	8
M8 x 12 Screw	8
M6 x 12 Screw	4
M5 x 12 Screw	4
Bumper 25mm	4
Bumper 17mm	4
Self Driving Screw	6
Spanner Tool	1
Wood Screw	8

Tools Required

3mm Allen Wrench
4mm Allen Wrench
5mm Allen Wrench
Screw Driver
#2 Phillips Driver

NATIONAL

Furniture with Personality™

Telephone 800.482.1717
Fax 812.482.8800
www.NationalOfficeFurniture.com

Part # 3024217
Rev. -

Printed in U.S.A.
© 2014 Kimball International, Inc.

Assembly Instruction

- 11** Attach all worksurfaces to the frames using the provided screws as shown in **Figure L**. Align the surfaces with the four pre-drilled holes in the surface. Also drive the four reaming screws into the holes. Re-attach the plastic end support arm covers after all screws have been attached.

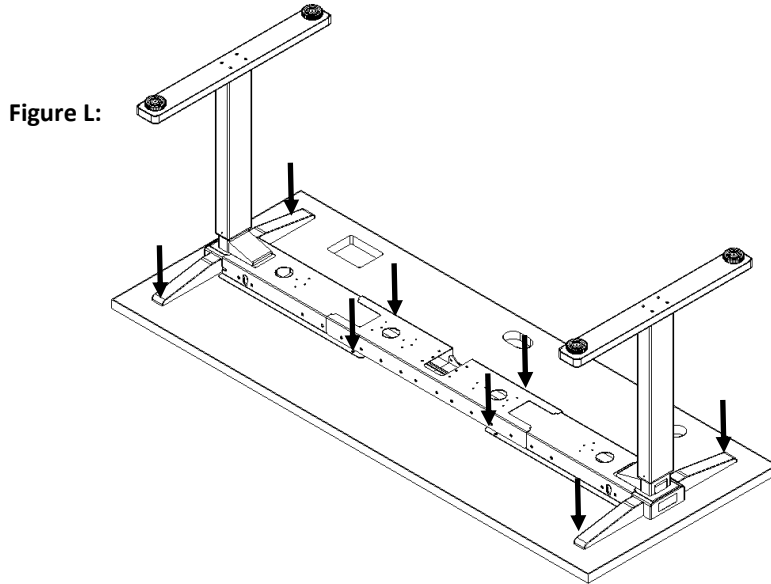

- 12** Attach the control box and control pad to the **underside** of the work-surface as shown in **Figure M**. Repeat the step for all worksurfaces to be assembled.

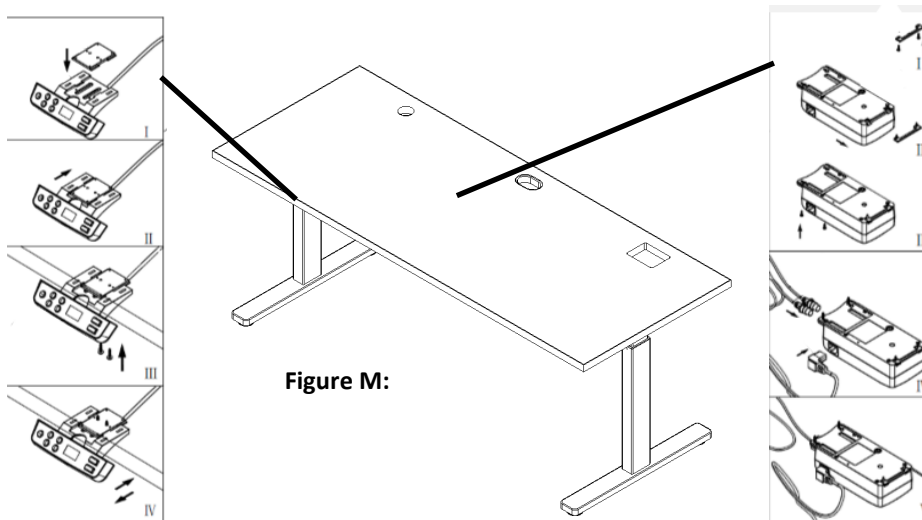

Alloy Adjustable Height Single Bases

Package Contents

Hardware	Qty
M8 x 16 Screw	20
M8 Nut	8
M8 x 12 Screw	8
M6 x 12 Screw	4
M5 x 12 Screw	4
Bumper 25mm	4
Bumper 17mm	4
Self Driving Screw	6
Spanner Tool	1
Wood Screw	8

Tools Required

3mm Allen Wrench
4mm Allen Wrench
5mm Allen Wrench
Screw Driver
#2 Phillips Driver

NATIONAL

Furniture with Personality™

Telephone 800.482.1717
Fax 812.482.8800
www.NationalOfficeFurniture.com

Part # 3024217
Rev. -

Printed in U.S.A
© 2014 Kimball International, Inc.

Proper product installation, in accordance with these instructions, is the responsibility of the installing agent. If you have any questions concerning these instructions, please call National Customer Service 800.482.1717.