

Assembly Instruction

Note: This assembly instruction will cover all configurations of the Alloy adjustable height single sided beams.

- 1** Attach each crosslink to the already assembled single depth station using the M8x12 Flat Head screws as shown in **Figure A**. Place the **crosslink covers** on both ends of each crosslink tube to hide all mounting hardware.

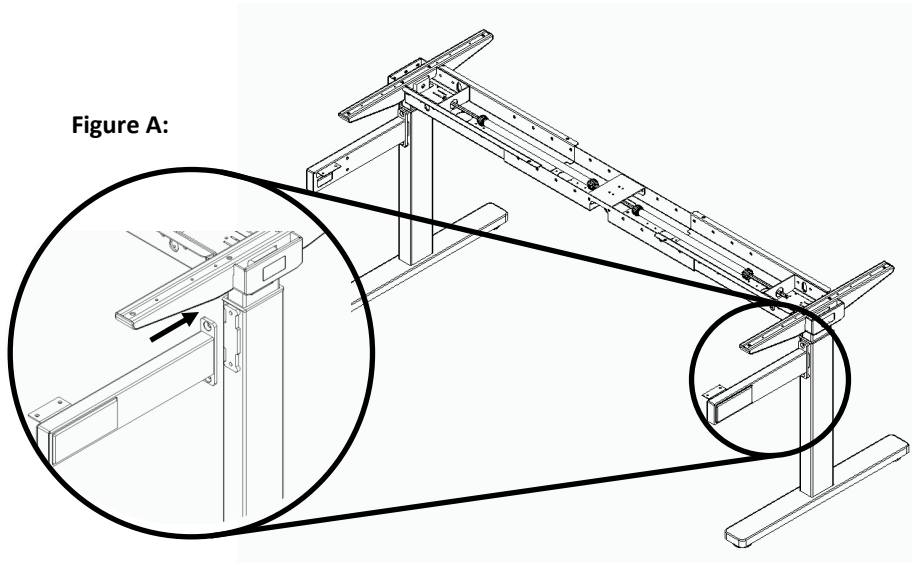

- 2** Place the beam between the crosslink tubes as shown in **Figure B**. Non powered and powered beams are installed in the same method.

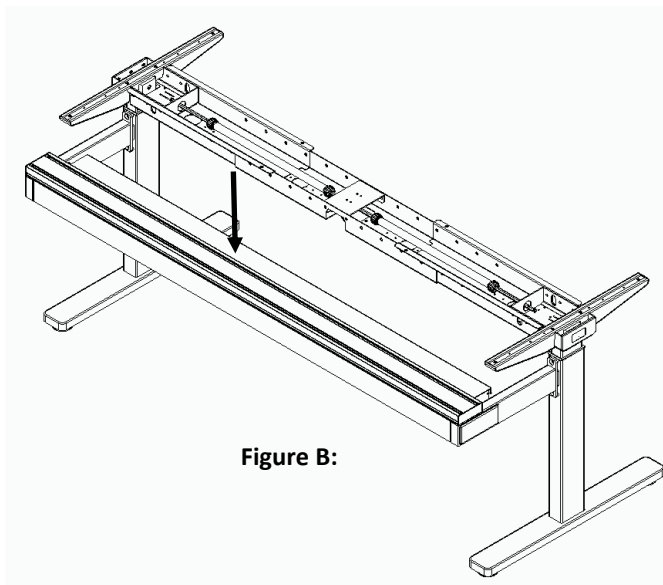

Alloy
Adjustable Single Beam

Package Contents

Hardware	Qty
M8 x 12 Screw	4
Self Driving Screw	4

Tools Required
5mm Allen Wrench
Screw Driver
#3 Phillips Driver

NATIONAL

Furniture with Personality™

Telephone 800.482.1717
Fax 812.482.8800
www.NationalOfficeFurniture.com

Part # 3051034
Rev. A

Printed in U.S.A.
© 2014 Kimball International, Inc.

Proper product installation, in accordance with these instructions, is the responsibility of the installing agent. If you have any questions concerning these instructions, please call National Customer Service 800.482.1717.

Assembly Instruction

- 3** From the bottom of the beam align the two outside v grooves with the four holes in the beam mounting brackets as shown in **Figure C**. Using the four provided self-drilling screws secure the beam to the crosslink tubes. Verify the beam is centered length wise between the crosslink tubes on both ends. It is recommended to use a clamp and pads when fastening the beam to help prevent misalignment.

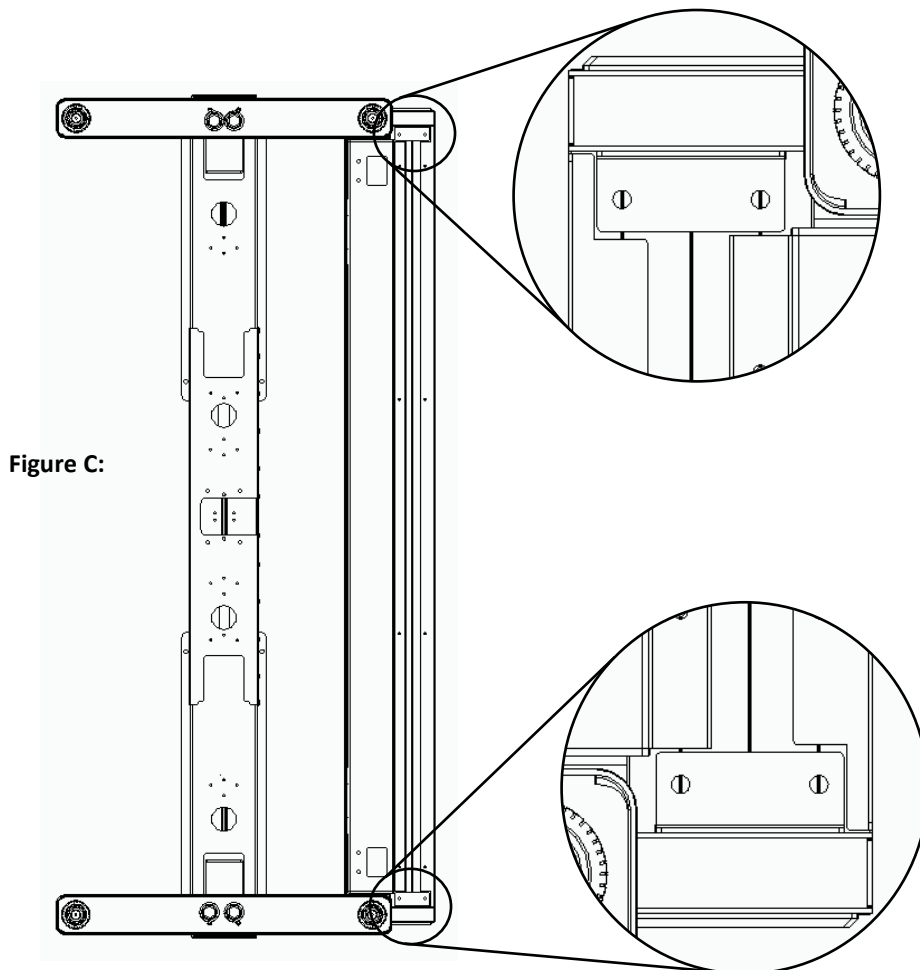

NATIONAL

Furniture with Personality™

Telephone 800.482.1717
Fax 812.482.8800
www.NationalOfficeFurniture.com

Part # 3051034
Rev. A

Printed in U.S.A.
© 2014 Kimball International, Inc.

Proper product installation, in accordance with these instructions, is the responsibility of the installing agent. If you have any questions concerning these instructions, please call National Customer Service 800.482.1717.