

## EVERYSPACE Privacy Screens

### Tools Required

- Box Cutter/Utility Knife
- Cordless Drill w/#2 Phillips head bit drive

### Hardware Required

- 1 - Privacy Screen
- 2 - Privacy Screen Brackets
- 8 - 1/4-20 X 3/4" Pan Head Phillips Wood Screws
- 2 - 1/4-20 X 1/2" Pan Head Phillips Machine Screws (**used for screen alignment**)
- 8 - Screen Spacers 1/4" Thick

### Installation

**Note: Privacy Screens should be installed after bases/tops.**

1. Using a knife, open box removing screen, brackets, and parts bag. See **Figure A**.
2. Lay screen on a non-marring surface for assembly.
3. Slide screen spacers over threaded inserts. Place screen brackets over (4) holes positioning as such shown in **Figure B**. Attach using drill w/#2 Phillips drive 1/4-20 X 3/4" machine screws through spacers into inserts. **Note: Don't over tighten or threaded inserts *might* pull out of core.**
4. When assembling screen to L-base or Single base, there is a range to mount screen either flush to top - or maximum 1" wire gap. **This is to ensure table stability. Don't exceed 1" gap between surface and screen. See Figure C for mounting options.**
5. When attaching screens to bench base, there **\*MUST\*** be a 1" gap in between screens for prevention of pinched fingers when screens raise and lower. See **Figure C**.
6. To attach privacy screens, the edge of screen and edge of work surface will set flush to each other as shown in **Figure C, left picture**. For screen attachments, using drill w/#2 Phillips drive, attach all #8 X 3/4" wood screws, 4 for each bracket to worksurface.

Figure A

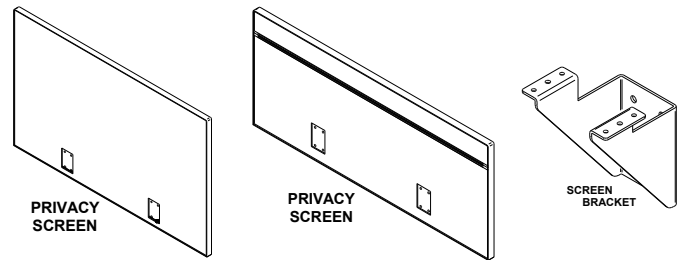

Figure B

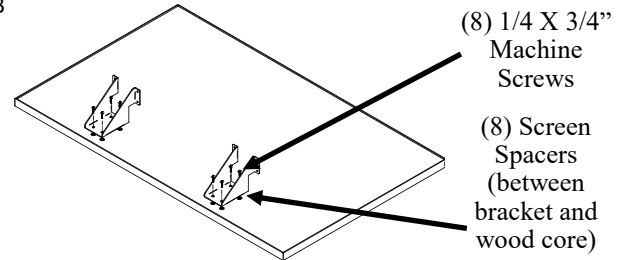
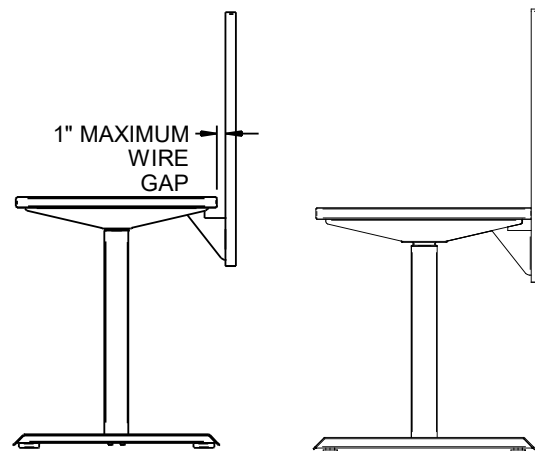

Figure C



## Installation (cont.)

7. After screens have been attached, sight down side view for **required** alignment of screen to screen. **See Figure E.**
8. To align screens vertically, locate the 1/4-20 X 1/2" pan head machine screw in parts bag. Thread screw into screen brackets on both sides until tension is felt. This will indicate screw is flush with the bottom of the work surface.
9. **Screen leaning in:** use #2 Phillips bit drive and unscrew back wood screws and tighten 1/4-20 X 1/2" Phillips machine screw until desired vertical position is obtained.
10. **Screen leaning out:** use #2 Phillips bit drive and unscrew front wood screws. Tighten 1/4-20 X 1/2" Phillips machine screw until desired vertical position is obtained.
11. Screw #8 X 3/4" wood screws back into work surface using #2 Phillips bit drive. **Note: Don't over tighten or screens will lean.**

Figure E

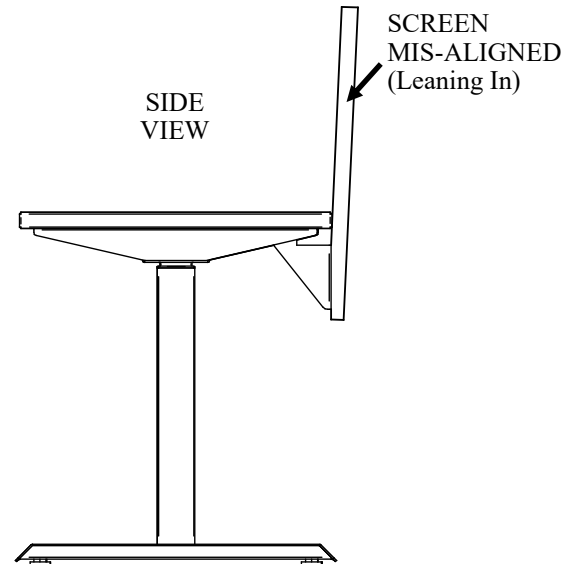

Figure F

