

Vora™ Assembly Instruction

1

Place seat assembly upside down on an elevated flat surface. Position swivel tilt control mechanism on bottom side of seat assembly to match the inside 4-hole configuration. Note: The swivel tilt control adjustment knob is to be positioned toward the front of the seat. The front of the seat is identified by the front asset label. Using the 5mm Hex Key Wrench, secure the swivel tilt control mechanism to the seat assembly using four 5/16-18 x 1" hex head bolts. Figure A.

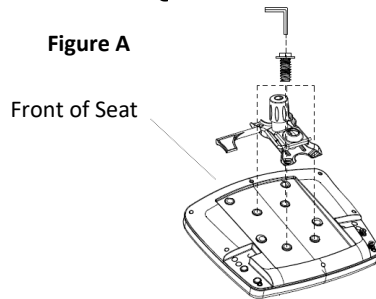

2

Position the right and left arm assemblies on the bottom of the seat as shown in Figure B. Note: To assure proper assembly of the right and left arms, each arm should angle toward the front of the seat, not rearward. Using the 5mm hex key wrench, secure each arm with three 5/16-18 x 1 1/4" hex head bolts.

3

Position the back assembly to the corresponding hole configuration on the back bottom of the seat assembly. Using the 5mm hex key wrench, secure the back assembly with four 5/16-18 x 1 1/4" hex head bolts. Figure C.

Figure B

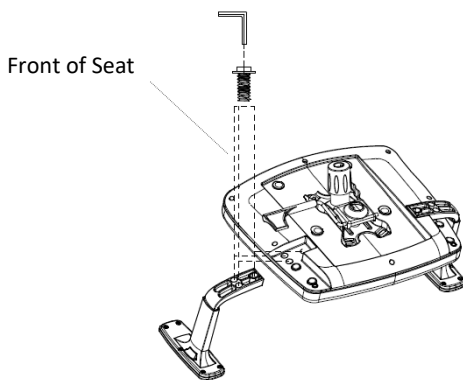
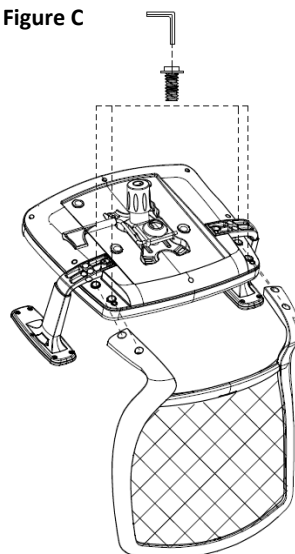

Figure C



Product Line

Vora™ Task Chair

Required Tools

- 5mm Hex Key Wrench (Included)

Package Contents

	Qty.
• Back assembly	1
• Plastic base	1
• Gas lift cylinder	1
• Seat assembly	1
• Hardware Kit:	
• 5/16-18 X 1" hex head bolts	4
• 5/16-18 X 1 1/4" hex head bolts	10
• Hex Key Wrench	1
• Right arm assembly	1
• Left arm assembly	1
• Swivel tilt control mechanism	1
• Set of five casters	1

NATIONAL

Telephone 800.482.1717
 Fax 812.482.8800
www.NationalOfficeFurniture.com

Part# 3215490
 Rev. B

Printed in U.S.A.
 ©2022 Kimball International, Inc.



Assemble units as described herein only. All screws and bolts must be tightened securely and checked periodically after assembly. Failure to assemble or to secure parts properly may result in assembly failure and personal injury.

Proper product installation, in accordance with these instructions, is the responsibility of the installing agent. If you have any questions concerning these instructions, please call National Customer Service 800.482.1717.

Assembly Instruction

4

Insert 5 casters into the plastic base as shown in Figure D.

Figure D

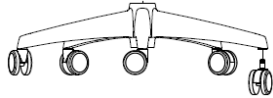

5

Orient the gas lift cylinder as shown and insert the larger end of the cylinder into the hole in the center of the base. Figure E.

Figure E

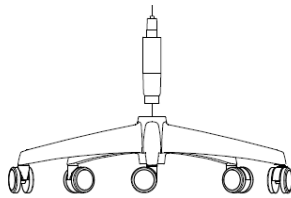

6

Carefully position the seat assembly over the gas lift cylinder, aligning the hole in the seat control with the top, smaller end of the cylinder. Press the seat assembly onto the cylinder then sit on the seat to completely mate the components together. While seated, actuate height control lever and remove weight from chair to adjust chair up to comfortable sitting height. Figure F.

Figure F

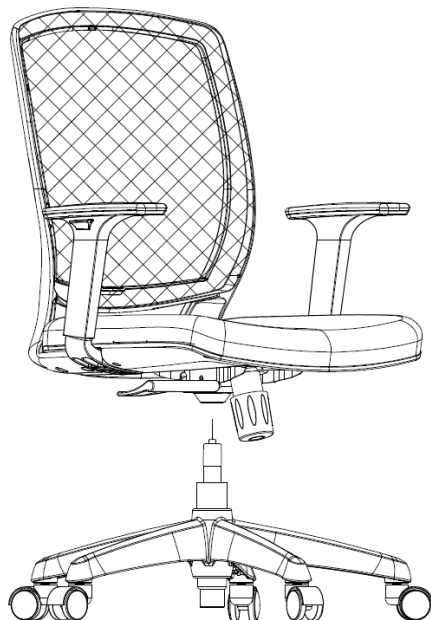

Proper product installation, in accordance with these instructions, is the responsibility of the installing agent. If you have any questions concerning these instructions, please call National Customer Service 800.482.1717.

NATIONAL.

Telephone 800.482.1717
Fax 812.482.8800
www.NationalOfficeFurniture.com

Part #3215490
Rev.B

Printed in U.S.A.
© 2022 Kimball International, Inc.