

# Service Manual

Side by Side Refrigerator



 **Electrolux**

# Table of Contents

<b>SAFE SERVICING PRACTICES</b> .....	<b>1</b>
<b>SECTION A - INSTALLATION</b> .....	<b>2</b>
UNCRATING .....	2
MODEL AND SERIAL NUMBER.....	2
AIR CIRCULATION .....	2
ELECTRICAL INFORMATION .....	3
LEVELING .....	3
DOOR REMOVAL .....	4
To Remove Refrigerator Door .....	4
To Remove Freezer Door .....	4
DOOR ALIGNMENT .....	6
<b>SECTION B - REFRIGERATOR CABINET</b> .....	<b>7</b>
BASIC CONSTRUCTION .....	7
COMPRESSOR MOUNTING .....	7
INSULATION AND INNER LINER .....	8
CABINET DOORS AND GASKETS .....	8
ADJUSTABLE DOOR BINS .....	8
FRONT AND REAR ROLLERS .....	9
To Remove Front Roller Assembly .....	9
To Remove Rear Roller .....	9
CABINET TOUCH-UP PROCEDURE .....	10
Lacquer Refinishing .....	10
<b>SECTION C - ELECTRICAL COMPONENTS</b> .....	<b>13</b>
ELECTRICAL GROUNDING .....	13
COMPRESSOR .....	13
Electrical Components and Circuits .....	13
Solid State Relay .....	13
To Check/Replace Relay .....	14
Overload Protector .....	14
To Check/Replace Overload Protector .....	14
Run Capacitor .....	15
To Check/Replace Run Capacitor .....	15
Compressor Start Circuit .....	16
Compressor Run Circuit .....	16
Compressor Operating Characteristics .....	16
Compressor Electrical Check .....	17
PERIMETER AND MULLION HOT TUBE .....	17
EVAPORATOR FAN & MOTOR ASSEMBLY .....	18
To Remove Evaporator Fan Motor .....	18

# II Table of Contents

---

DEFROST THERMOSTAT .....	19
To Test Defrost Thermostat .....	19
To Remove Defrost Thermostat .....	19
DEFROST HEATER.....	20
How To Remove Defrost Heater .....	20
<b>SECTION C - ELECTRONIC CONTROLS .....</b>	<b>22</b>
ELECTRONIC CONTROL SYSTEM .....	22
Damper Assembly.....	22
Freezer Temperature Control .....	22
Fresh Food Temperature Control .....	22
Defrost Heater .....	22
Defrost Termination Thermostat (DTT) .....	23
Standard Compressor .....	23
Evaporator Fan .....	23
Condenser Fan .....	23
Fresh Food Door Sensor .....	23
Air Filter .....	23
Sensors .....	23
Fresh Food Lights .....	23
Alarm.....	24
Control, Main Board.....	24
Control, User Interface .....	24
Numeric Display .....	24
Fahrenheit & Centigrade Temperature .....	24
Showroom Setting .....	24
ALARMS AND SIGNALS .....	25
Temperature Alarm .....	25
Alarm Condition .....	25
Door Ajar LED (flashing green) .....	25
Door Ajar & High Temp .....	26
Power Failure (flashing yellow) .....	26
Power Failure & High Temp.....	26
High Temp .....	26
Alarm OFF .....	27
SHOWROOM SETTING .....	27
Activation .....	27
Deactivation .....	27
Active Function Displays .....	27
Fresh Food Lights .....	27
Change Between Fahrenheit & Centigrade .....	28
Advance Into Defrost Cycle Manually .....	28
Activation.....	28
Deactivation .....	28

---

# Table of Contents



OPERATION - UPDATED REVISION L .....	28
User Interface - Version A.....	28
Freezer .....	28
Fresh Food .....	29
Temperature Alarm .....	29
Air Filter Control .....	29
Fast Freeze/Fast Ice Mode .....	29
Over Temperature Shut Off .....	30
User Interface - Version B.....	30
Freezer .....	30
Fresh Food .....	30
DIAGRAMS .....	32
Diagram A - Controller, Main Board .....	32
Diagram B - Controller, User Interface Board .....	33
Wiring Diagrams .....	34
Performance Data Sheet .....	36
SERVICE DIAGNOSTIC MODE .....	37
View .....	37
Test .....	37
Deactivation .....	38
Service Test Menu .....	38
Test 1 - Firmware Version .....	38
Test 2 - Evaporator Fan Test .....	38
Test 3 - Freezer Temperature, Last 24 Hours .....	38
Test 4 - Fresh Food Temperature, Last 24 Hours .....	39
Test 5 - Damper Motor is a 12 Volt DC Stepper Motor .....	39
Test 6 - Defrost .....	40
Test 7 - Compressor and Condenser Fan On .....	40
Test 8 - Default Settings / Clear Service Data .....	40
Manual Defrost .....	41
Function .....	41
Show Room Mode .....	41
Changing Between Fahrenheit to Centigrade On The Display .....	41
Diagram C - Service Mode Display Routine .....	41
CONTROL REMOVAL & INSTALLATION .....	42
To Service the Control Board .....	42
To Service The Power Board .....	43
To Replace the Damper .....	44
Food Compartment Light Switch .....	45
SYSTEM EXPLODED VIEW .....	46
<b>SECTION D - AIR CIRCULATION .....</b>	<b>47</b>
Principles of Automatic Defrost Operation .....	47
Air Circulation Patterns .....	47

# IV Table of Contents

---

<b>SECTION E - REFRIGERATION SYSTEM.....</b>	<b>48</b>
DEFINITIONS .....	48
Recovery.....	48
Recycling.....	48
Reclaim .....	48
SAFETY WARNINGS .....	49
Compressor Testing.....	49
Charging Sealed Systems.....	49
Soldering.....	49
BASIC COMPONENTS .....	50
Perimeter Hot Tube .....	50
Refrigerant Cycle .....	51
TESTING FOR REFRIGERANT LEAKS .....	52
CHECKING FOR INTERNAL (HOT TUBE) LEAKS .....	52
COMPRESSOR REPLACEMENT .....	53
To Use Dry Nitrogen to Flush the System .....	54
To Use Refrigerant to Flush the System .....	54
Installing a New Compressor .....	55
EVAPORATOR REPLACEMENT .....	58
HEAT EXCHANGER REPLACEMENT .....	60
PERIMETER HOT TUBE REPAIR KIT .....	62
Bypassing Perimeter Hot Tube - Step 1 .....	62
Installing the Heater Wire - Step 2 .....	63
Installing the Heater Wire - Step 3 .....	64
CONDENSER REPLACEMENT .....	65
FILTER-DRIER INSTALLATION.....	66
EVACUATING AND RECHARGING .....	67
Equipment Needed For Evacuation & Recharging .....	68
Installing Evacuation & Recharging Equipment .....	68
Evacuating System .....	68
Charging the System .....	69
Preparing the Charging Cylinder.....	70
Final Leak Test.....	70
R-134a SERVICE INFORMATION .....	72
Verify Refrigerant Type In the System .....	72
Dedicated Equipment.....	72
R-134a Refrigeration Systems .....	72
Miscibility of R-134a and Ester Oil .....	73
Water In the Refrigeration System .....	74
Vacuum Pump Maintenance.....	75

---

# Table of Contents

Refrigerant Leaks .....	76
Leak Detection .....	76
R-134a Properties .....	76
HFC-134a, CFC-12 Pressure Temperature Chart .....	77
R-134a HEALTH AND SAFETY INFORMATION .....	78
Inhalation Toxicity .....	78
Cardiac Sensitization .....	78
Spills or Leaks .....	79
Skin and Eye Contact .....	79
Combustibility of HFC-134a .....	80
Leak Testing .....	80
Bulk Delivery and Storage .....	80
Filling and Charging Operations .....	80
Refrigerant Recovery Systems .....	81
Thermal Decomposition .....	81

## **SECTION F - ICE MAKER..... 83**

REAR MOUNTED ICE MAKER FOR COUNTER DEPTH MODELS .....	83
Front Cover .....	83
Ice Mold .....	83
Mold Heater .....	84
Ice Stripper .....	84
Ice Ejector .....	84
Water Valve Assembly .....	84
Thermostat .....	84
Sensing Arm & Linkage .....	85
Timing Switches .....	85
Thermal Cut-Out(TCO) .....	85
Timing Cam & Coupler .....	86
Timing Gear .....	86
Motor .....	86
On / OFF Switch .....	86
Wiring .....	86
Installing Water Supply Line to Ice Maker .....	87
Test Cycling Ice Maker .....	87
Water Valve Switch - Water Fill Volume.....	87
Parts Replacement .....	88
To Replace Front Cover .....	88
To Replace Fill Trough and Bearings .....	88
To Replace Ice Stripper .....	89
To Replace Motor & Switch Mounting Plate .....	89
To Replace Motor .....	89

# VI Table of Contents

---

To Replace Water Fill Switch .....	90
To Replace Ejector Blades .....	90
To Replace Hold Switch .....	90
To Replace Ice Maker Control Arm Shut-Off Switch .....	91
To Replace Ice Maker Thermostat .....	91
To Replace Thermal Cut-Out (TCO) .....	91
To Replace Mold Heater .....	92
<b>FAULT DIAGNOSIS .....</b>	<b>93</b>
Complaint - Ice Maker Fails to Start .....	93
Complaint - Ice Maker Fails to Complete Cycle .....	93
Complaint - Ice Maker Fails to Stop At End Of Cycle .....	93
Complaint - Ice Maker Continues To Eject When Container is Full .....	94
Complaint - Ice Maker Produces Undersized Ice Pieces .....	94
<b>ICE MAKER TESTING PROCEDURES .....</b>	<b>94</b>
Operating Cycle .....	94
Operating Cycle Illustrations - Manual Cycle .....	95
Operating Cycle Illustrations - Electrical .....	95
Operating Cycle Illustrations - Mechanical .....	102
Ice Maker Wiring Diagrams .....	105
<b>SECTION G - ICE &amp; WATER DISPENSER .....</b>	<b>107</b>
<b>ICE DISPENSER CONTAINER &amp; RAIL ASSEMBLY .....</b>	<b>107</b>
Dispenser Auger Motor & Solenoid Assembly .....	107
To Remove Auger Motor .....	107
To Test Auger Motor .....	108
To Remove Solenoid Assembly .....	108
To Test Solenoid Assembly .....	108
To Remove Lamp Socket and Light Bulb .....	109
<b>ICE AUGER &amp; CRUSHER ASSEMBLY .....</b>	<b>109</b>
To Remove Ice Auger & Crusher Assembly .....	109
To Replace Crusher Blades .....	110
<b>ICE &amp; WATER DISPENSER ASSEMBLY .....</b>	<b>110</b>
Feature Levels .....	110
Seven Selection Dispenser .....	110
Icon Model Dispenser .....	111
Six Selection Dispenser .....	111
Electrical / Mechanical Dispenser .....	111
Gaining Access .....	111
Fast Freeze - Fast Ice .....	116
How To Test The Electronic Dispenser .....	118
<b>SECTION H - WATER SYSTEMS .....</b>	<b>123</b>
Water Valve .....	123
PureSource Water Filters .....	124

---

# Table of Contents

# VII

---

Water Tanks .....	124
Front Filter System .....	125
Rear Filter System .....	125
To Test The Water Fill System .....	126
Resistance Check .....	127
Voltage Check for Water to Ice Maker .....	127
Digital Meter .....	127
Voltage Drop From Heater .....	127
Different Voltage Readings Between Primary & Secondary Valve Coils .....	127
No Water At Door .....	128
Diode Kit .....	128
Checking Water .....	128
Ice Maker Valve .....	128
Chilled Water Valve .....	128
Low/No Voltage At Coil(s) .....	128

---

# SAFE SERVICING PRACTICES

# 1

To avoid personal injury and/or property damage, it is important that **Safe Servicing Practices** be observed. The following are some limited examples of safe practices:

1. **DO NOT** attempt a product repair if you doubt your ability to complete it in a safe and satisfactory manner.
2. Before servicing or moving an appliance:
  - Remove power cord from the electrical outlet, trip circuit breaker to the **OFF** position, or remove fuse
  - Turn off gas supply
  - Turn off water supply
3. Never interfere with the proper operation of any safety device.
4. **Use The Correct Replacement Parts Cataloged For This Appliance. Substitutions May Defeat Compliance With Safety Standards Set For Home Appliances.**
5. **GROUNDING:** The standard color code for safety ground wires is **GREEN**, or **GREEN** with **YELLOW STRIPES**. **DO NOT** use ground leads as current carrying conductors. It is **EXTREMELY** important that the service technician reestablish all safety grounds prior to completion of service. Failure to do so will create a hazard.
6. Prior to returning the product to service, ensure that:
  - All electrical connections are correct and secure
  - All electrical leads are properly dressed and secured away from sharp edges, high-temperature components, and moving parts
  - All non-insulated electrical terminals, connectors, heaters, etc. are adequately spaced away from all metal parts and panels
  - All safety grounds (both internal and external) are correctly and securely connected
  - All panels are properly and securely reassembled



## WARNING

This service manual is intended for use by persons having electrical and mechanical training and a level of knowledge of these subjects generally considered acceptable in the appliance repair trade. Electrolux Home Products cannot be responsible, nor assume any liability, for injury or damage of any kind arising from the use of this manual.

## 2 Section A - Installation

### UNCRATING

Uncrating instructions are clearly printed on the shipping carton. Under no circumstances should a refrigerator be uncrated until these instructions have been read.

Additional handling and installation information is provided in the "Installation Tips" affixed to the refrigerator door and in the Owner's Guide, located in one of the drawers inside the refrigerator. Pay particular attention to the information regarding hand trucking, leveling and door alignment.

### MODEL AND SERIAL NUMBER

Model and Serial Numbers are found on the Serial Plate located on the ceiling of the refrigerator compartment, just behind the compartment light, or on the right side at the top. (See Figure A1.)

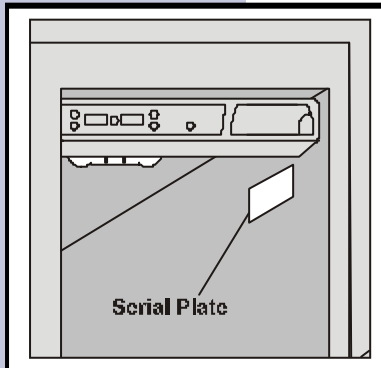

#### CAUTION

Do not install the refrigerator where the temperature will drop below 55°F (13°C), or rise above 110°F (43°C) because the compressor will not be able to maintain proper temperatures.

### AIR CIRCULATION

Proper air circulation must be maintained for efficient refrigerator operation. Refer to the Owner's Guide for recommended clearances. Install the refrigerator out of direct sunlight and away from the range, dishwasher, or other heat sources. Allow an extra 3/8" on the top and sides, and 1" from the back for ease of installation, proper air circulation, and plumbing and electrical connections. If the hinge side of the unit is placed against a wall, allow a 1/2" minimum between hinges and wall to permit proper door swing.

#### NOTE

Do not block the toe grille on the lower front of the refrigerator. Sufficient air circulation is essential for proper operation of the refrigerator.

# Section A - Installation 3

## ELECTRICAL INFORMATION

The refrigerator must be plugged into its own 115 Volt, 60 Hz, AC only electrical outlet. The circuit should be protected by a 15 or 20 Amp circuit breaker or time delay type fuse.

### NOTE

If voltage varies by  $\pm 10\%$  of 115 volts, performance of the refrigerator may be affected. Operating the refrigerator with insufficient power can damage the compressor.

The refrigerator power cord is equipped with a three prong grounding plug. It must be plugged directly into a properly grounded three prong receptacle. The receptacle must be installed in accordance with local codes and ordinances. **Do not use an extension cord or an adapter plug.**

## LEVELING

The refrigerator must be leveled with all bottom corners resting firmly on a solid floor. Adjust the front rollers to level the cabinet from side-to-side and front-to-rear. Keep the cabinet as low as possible for stability. Never adjust the cabinet rollers so the front is lower than the rear.

### NOTE

Rear rollers are not adjustable.

To adjust the front rollers:

1. Open refrigerator and freezer doors.
2. Remove toe grill by removing two screws and pulling it straight out. (See Figure A2.)
3. Adjust rollers by turning each roller adjusting bolt with flat-blade screwdriver, adjustable wrench, 3/8" socket wrench, or 3/8" nutdriver until refrigerator is level and stable. (See Figure A3.)

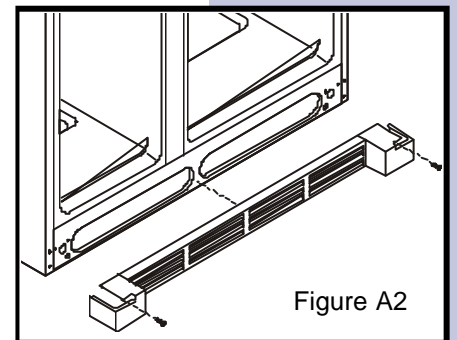

Figure A2

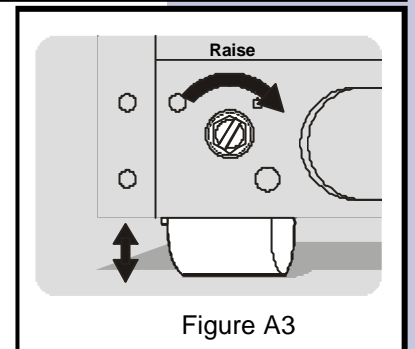

Figure A3

# 4 Section A - Installation

## DOOR REMOVAL

### NOTE

If installation requires the removal of the doors, trace around all hinges with a soft lead pencil for easy relocation.

1. Disconnect electrical supply.
2. Open both doors, then remove toe grille.
3. Close doors.

### To Remove Refrigerator Door:

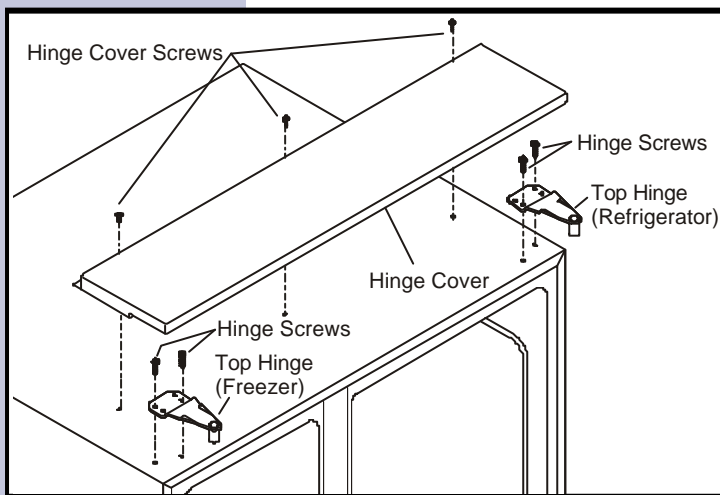

1. Remove two Hinge Cover screws. Remove cover.
2. Trace around hinge with soft lead pencil. This will make it easier to realign doors when they are replaced.
3. Remove Top Hinge (Refrigerator).
4. Lift refrigerator door off bottom hinge pin. Set door aside.
5. Remove bottom hinge, if necessary.
6. Reverse this procedure to reinstall refrigerator door.

### To Remove Freezer Door:

1. Disconnect water line that goes through lower hinge of freezer door at connection located under front of freezer: Grip water line firmly in one hand, then with 3/8" wrench or fingers, push in on gray collar to release water connector.

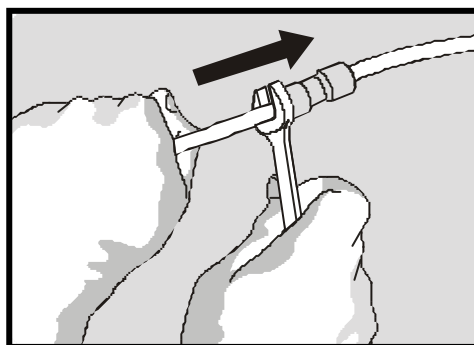
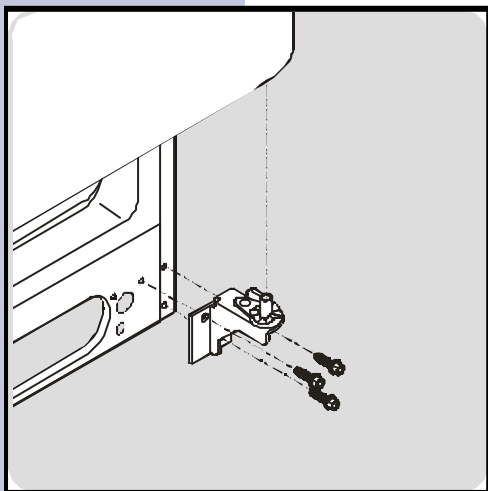

# Section A - Installation **5**

2. Remove Hinge Cover screws, then remove cover.

3. Disconnect wiring harness connector plug at top hinge. Place your thumbs on flat sides of each connector, bending both sides back and forth, then with firm grasp, pull both pieces apart.

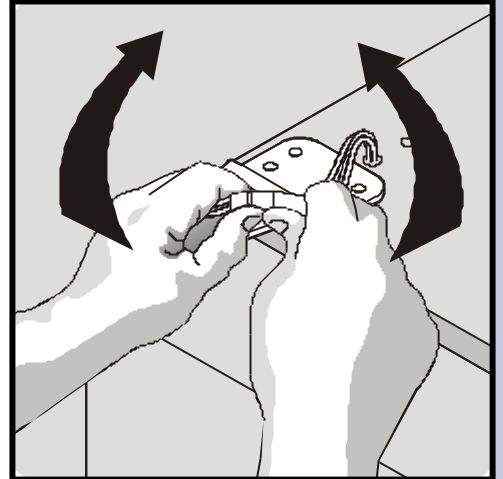
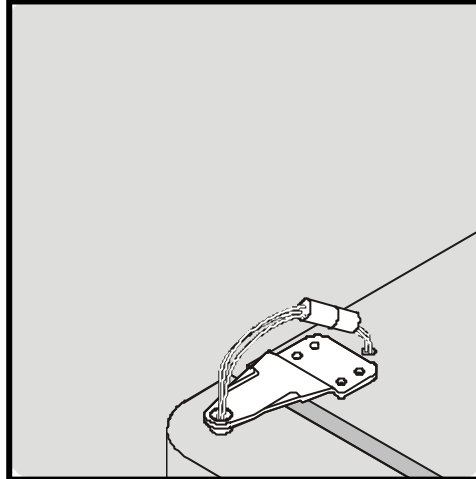

4. Trace around hinge with soft lead pencil. This will make it easier to realign doors when they are reinstalled.

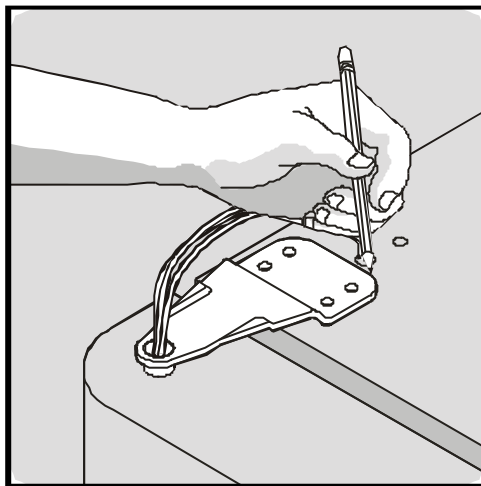

5. Remove top hinge, allowing wiring harness to pull through hinge.

6. Lift freezer door off bottom hinge pin. Lay door down flat to avoid kinking water line.

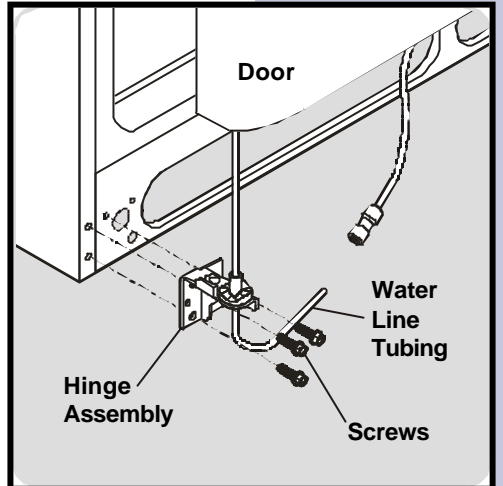

7. Remove bottom hinge, if necessary.

8. Reverse this procedure to reinstall freezer door.

# 6 Section A - Installation

## DOOR ALIGNMENT

Due to their large size, Side by Side cabinets may flex when installed on an uneven floor. To correct alignment, proceed as follows:

1. Level refrigerator, front to back and side to side. Open doors and rock refrigerator after each adjustment to relieve cabinet strains.
2. After refrigerator is level, close doors and check for proper alignment.
3. If refrigerator door is higher than freezer door, raise left corner of cabinet by adjusting roller.
4. If refrigerator door is lower than freezer door, raise right corner of cabinet by adjusting roller.
5. After cabinet is leveled and doors are properly aligned, ensure refrigerator sets solidly on all four corners.

When both doors have been reinstalled and are correctly aligned, replace toe grille and plug in electrical power cord. Turn both temperature controls to center position. Adjust settings as necessary.

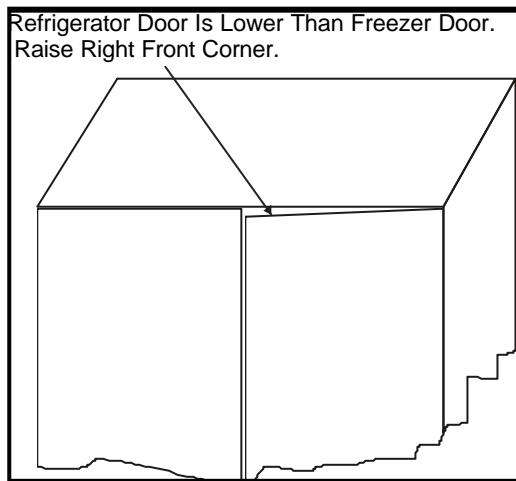
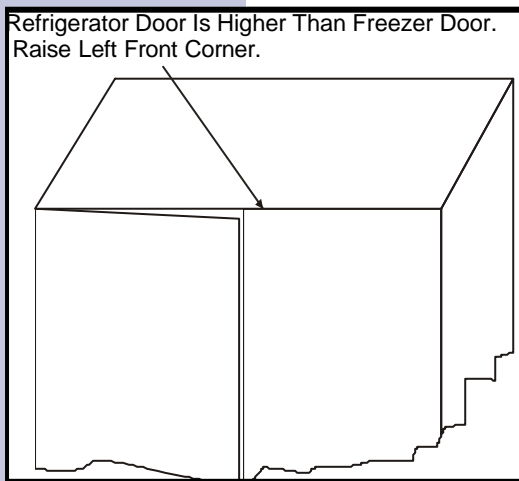

# Section B - Refrigerator Cabinet 7

## BASIC CONSTRUCTION

Counter Depth models have clean back cabinets and/or forced air condensers. The condenser is located under the cabinet bottom. The cabinet wrapper consists of a one-piece top and sides formed of prepainted steel, with an interlocking, snap-in, galvanized steel back panel. A separate steel frame is attached to the cabinet bottom. The compressor compartment houses the compressor, condenser, and fan motor.

All cabinet seams have special sealing materials applied as vapor barriers, prior to installation of the inner liner and foam insulation.

## COMPRESSOR MOUNTING

All basic Construction Counter Depth models Side by Sides will have a dynamic condenser and a unitary drain pan assembly that is mounted to the bottom of the refrigerator cabinet just behind the toe grille. (See Figure B1.)

The compressor is mounted on rubber grommets with metal inserts, then bolted to the base using four Hex head, 14-28 shoulder screws. (See Figure B2.)

Figure B1

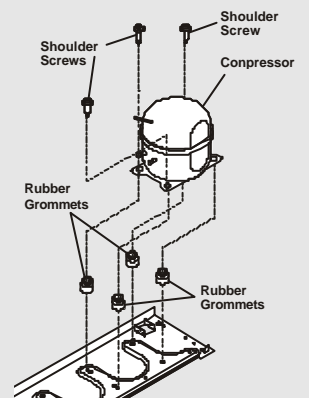
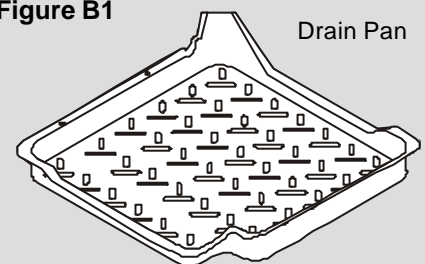

Figure B2

# 8 Section B - Refrigerator Cabinet

## INSULATION AND INNER LINER

The cabinet wrapper and compartment liner are bonded together with a core of "Urethane" foam insulation to form a slim three-ply wall of single-unit construction.

The one piece freezer and the one piece food inner liners are vacuum formed of tough corrosion-proof ABS/HIPS plastic material. The liners are not removable.

## CABINET DOORS AND GASKETS

The exterior door panels are made from one piece of heavy gauge, deep drawn, cold-rolled steel. A wide flange at the periphery is formed integral with the exterior door panel.

Counter Depth model doors are filled with rigid Urethane foam insulation after assembly of the inner panel and prior to the installation of the door gasket.

The door inner panels are vacuum formed from high strength plastic.

## ADJUSTABLE DOOR BINS

Some models have adjustable door bins that can be moved to suit individual needs.

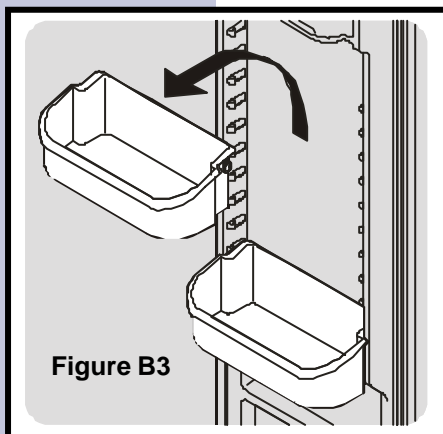

To move door bins:

1. Lift bin straight up.
2. Remove bin.
3. Place bin in desired position.
4. Lower bin onto supports until locked in place.

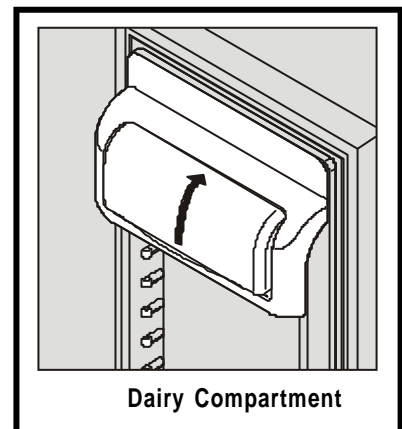

# Section B - Refrigerator Cabinet 9

## FRONT AND REAR ROLLERS

The front roller is mounted with two screws to the cabinet base and one screw to the front of the cabinet. (See Figure B4.) The adjustment screw at the top of the roller is turned clockwise to raise the cabinet, and counterclockwise to lower the cabinet. (See Figure B5.) While making adjustments, slightly raise the cabinet to reduce the strain on the roller assembly.

### To Remove Front Roller Assembly:

1. Disconnect refrigerator from electrical power.
2. Raise and support cabinet.
3. Remove two bolts securing roller to bottom of refrigerator.
4. Remove one screw securing roller to front of cabinet. Roller should fall free.
5. Reassemble in reverse order.

### To Remove Rear Roller: (See Figure B6)

1. Disconnect refrigerator from electrical power.
2. Raise and support cabinet.

#### NOTE

The rear roller assembly is mounted to the bottom of the compressor base. Raise and support cabinet before removing rear roller.

3. Squeeze flared end of roller pin together using pair of pliers or vise grips.

#### NOTE

The end of the roller pin that protrudes through the roller has been flared to prevent it from slipping out. You will have to squeeze it back together with a pair of pliers before it will slide out for removal.

4. Pull roller pin free of roller and compressor base. Roller should fall free. If not, you may have to tap roller lightly with hammer to free it from compressor base.
5. Reassemble in reverse order.

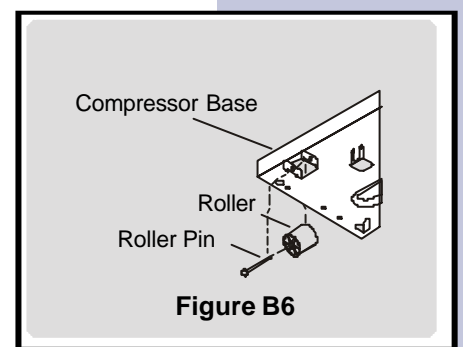
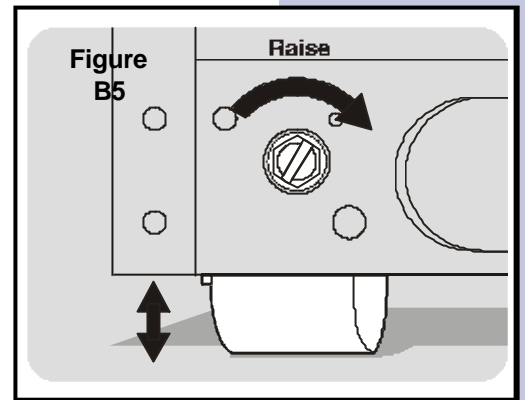
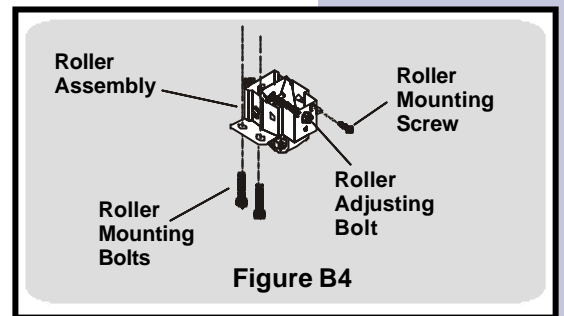

# 10 Section B - Refrigerator Cabinet

---

## CABINET TOUCH-UP PROCEDURE

---

Vinyl gaskets are used on all models. Lacquer repairs can be made on all areas of the cabinet except any painted surface that comes in contact with the vinyl gasket. Since prolonged contact of vinyl gaskets with lacquer will soften the lacquer, repairs in these areas should not be attempted.

### Lacquer Refinishing

The following steps to touch-up or refinish a acrylic painted cabinet, **except in gasket contact areas.**

1. Sand out spot to be repaired with 360 or 400 wet-or-dry sandpaper. Finish sanding to feather edge with 600 wet-or-dry sandpaper. Wipe area dry. Hand rub with fine rubbing compound (Dupont VZ1090® or equivalent), the area extending at least six inches beyond edges of lacquer repair spot. Wipe compound off and wash area with Naphtha. Dry with clean cloth.
2. Prepare bare metal with Sol-Kleen® cleaner and rust remover. Reduce cleaner with two parts water, and apply with a clean wet rag. Do not touch painted surface with this cleaner. Stubborn or deep seated rust can be removed by applying cleaner with steel wool.

#### NOTE

Prepare surface of bare metal with Sol-Kleen® regardless if rust is present.

3. Before cleaner dries, wipe surface dry with clean rag.
  4. Wipe over surface thoroughly second time with solution of 50-50 alcohol and water. Wipe again with clean dry rags, preferably new cheesecloth.
  5. Allow to dry for at least 10 to 15 minutes.
  6. Apply primer surfacer, reduced by approximately equal parts of lacquer thinner, to build bare metal area up to surrounding surface. Any imperfections which primer has not filled should be knifed out with lacquer type putty glaze.
  7. If no putty glaze is used, allow to dry about 30 minutes and, if necessary, sand out lightly with 360 wet-or-dry sandpaper. If putty glaze is used, allow about three hours before sanding with sandpaper and water. Remove sanding residue thoroughly by wiping with clean rag soaked in naphtha. Wiping surface with tack rag will remove dust and lint.
  8. Finish repair with two or more coats of lacquer (reduce approximately one part of lacquer to 1½ parts of thinner). Finally, apply mist coat of lacquer thinner to flow out surface.
-

## CABINET TOUCH-UP PROCEDURE (CONT.)



9. Patched area should be allowed to dry three or more hours before rubbing with compound or polish.

This procedure also applies to the complete refinishing of the cabinet, except gasket contact areas. All damaged areas should be repaired as outlined in steps 1 through 6 on the previous page. The overall surface of the cabinet should be sanded thoroughly and cleaned as outlined in step 7.

The cabinet should be given two or more coats of touch-up lacquer and polished as outlined in steps 8 and 9.



## ELECTRICAL GROUNDING

All refrigerators are equipped with a power supply cord incorporating a three-prong grounding plug and a ground wire which is attached to the refrigerator cabinet for protection against shock hazard. Each electrical component is either cabinet mounted or connected through a ground wire to the cabinet to complete the ground. Certain components, such as defrost timers, may be double insulated and do not require a ground wire.

Ensure the electrical wall receptacle is of the three prong type and is properly grounded in accordance with the National Electrical Code and/or local codes.

## COMPRESSOR

### Electrical Components and Circuits

The new series of very high efficiency compressor is equipped with all new electrical components consisting of a solid state PTC relay with a thermally operated overload protector, and a run capacitor.

### Solid State Relay

The solid state relay has no moving parts. It consists of a PTC resistor mounted in a plastic case with appropriate terminals. PTC (Positive Temperature Coefficient) simply denotes a resistor which increases in resistance as its temperature is increased. The self-heating PTC resistor used in the solid state relay has the unique characteristic of changing from low to very high resistance very abruptly, thus serving as an on-off switch. (See Figure C1.)

The solid state relay plugs directly onto the compressor start and run terminals. Relay terminal 1 is for the neutral connection, A run capacitor is connected to relay terminals 2 and 3, so it is connected in parallel with the PTC resistor. Terminals 5 and 6 are internal; 5 is connected to the main winding and 6 to the start winding. One side of the 120 VAC power is connected to relay terminal 1. The other side of line is connected to the overload protector. (See figure C1.)

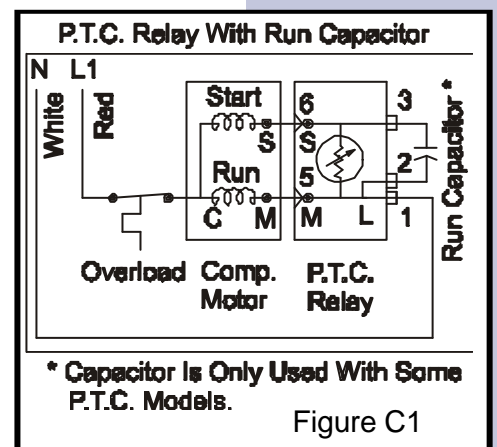

# 14 Section C - Electrical Components

## To Check/Replace Relay

1. Disconnect electrical supply to refrigerator.
2. Remove bale wire holding relay to compressor.
3. Remove relay assembly from compressor. (See Figure C2.)
4. Use small, flat-bladed screwdriver to disconnect leads to relay assembly.
5. Use flat headed screwdriver to gently pry capacitor from relay assembly.
6. Use ohmmeter to check resistance between terminals 5 and 6. Resistance should be 3 to 12 ohms, at normal room temperature. Shorted relay will read 0 ohms. Open relay will read very high or infinite resistance.
7. If ohm readings are out of range, replace relay.
8. Reverse this procedure to re-assemble.

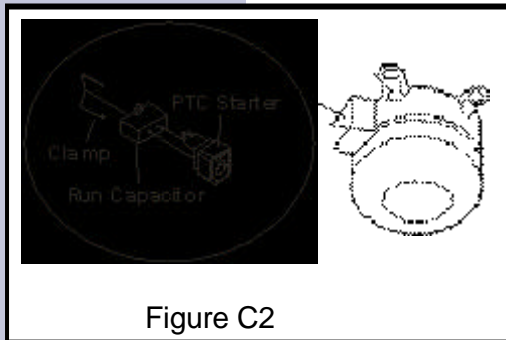

Figure C2

### NOTE

When replacing leads to the PTC relay, ensure locking tabs snap into terminal.

## Overload Protector

The overload protector is completely thermally operated. It will open from excessive heat or current. Unlike prior overloads, the internal bi-metal is not self-heating, and is not a part of the electrical circuit. The overload has a small built-in coil heater that is in series with the compressor start and run windings. (See Figure C1.)

## To Check/Replace The Overload Protector

1. Disconnect electrical supply to refrigerator.
2. Remove bale wire holding relay to compressor.
3. Remove relay assembly from compressor.
4. Use flat headed screwdriver to gently pry capacitor from relay assembly.

5. Use small, flat-bladed screwdriver to disconnect leads to relay assembly.

## NOTE

On some models you will have to remove bale wire and cover, to gain access to relay and overload protector.

6. Use ohmmeter to check resistance between tab terminal and female pin terminal. Overload protector should have less than 1 ohm of resistance at normal room temperature.
7. If ohm readings are out of range, install new Starter/Overload Assembly.

## NOTE

The Overload Protector is built into the Starter Overload Assembly.

8. Reverse this procedure to re-assemble.

## NOTE

When replacing leads to the PTC Relay, ensure the locking tabs snap back into the terminal.

## Run Capacitor

The run capacitor has permanently attached terminals which are connected to relay terminals 2 and 3.

## To Check/Replace The Run Capacitor

1. Disconnect electrical supply to refrigerator.
2. Remove bale wire holding relay to compressor.
2. Use small, flat-bladed screwdriver to disconnect leads to relay assembly.
3. Use flat-bladed screwdriver and gently pry capacitor from relay assembly.
4. Discharge capacitor by shorting across terminals with 500K (1 watt) resistor for one minute.
5. Use ohmmeter set on the “**Ohms times 1000**” scale (if available), to check resistance across capacitor wire terminals.
  - The needle should jump towards zero ohms and quickly move back to infinity.
  - If the needle does not move, the capacitor is open.
  - If the needle reads a constant value at or near zero ohms, the capacitor is shorted out.
  - If the needle jumps toward zero and then moves back to constant high resistance (not infinity), the capacitor has a high resistance leak.

# 16 Section C - Electrical Components

6. If ohm readings are out of range, replace capacitor.
7. Reverse procedures to re-assemble.

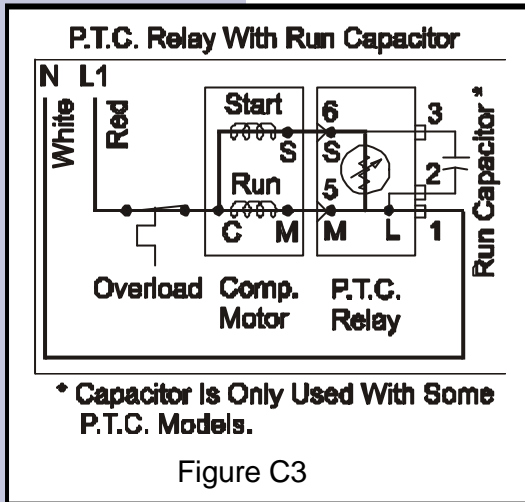

## Compressor Start Circuit

When the compressor circuit is first energized, the solid state relay has low resistance (3-12 ohms), and both the run and start windings are energized to start the compressor. The run capacitor is being bypassed by the relay, and it has a minor function during compressor starting. (See Figure C3.)

## Compressor Run Circuit

When the self-heating solid state relay has reached sufficient temperature, it will abruptly change from low resistance (3-12 ohms) to very high resistance (10-20K ohms) and, in effect, switches off the start windings.

The relay no longer shunts the run capacitor. The run capacitor is now in series with the start windings. The only purpose of the run capacitor is to improve compressor operating efficiency, which it does by correcting the power factor of the compressor motor. (See Figure C4.)

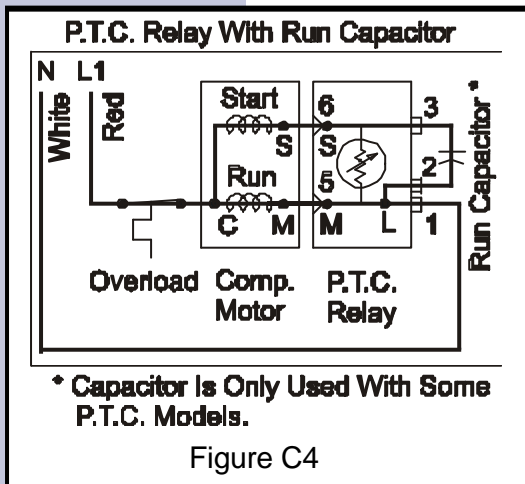

## Compressor Operating Characteristics

- When the compressor electrical circuit is energized, the start winding current causes the relay to heat and switch off the start winding circuit.

### NOTE

The relay will switch off the start winding circuit even though the compressor has not started (as when attempting to re-start after momentary power interruption).

- The overload protector is designed and calibrated to open the compressor electrical circuit with locked rotor run winding current only.

- With an open relay, the compressor will not start since there is little or no current to the start windings. The overload protector will open due to high locked rotor run winding current.
- With a shorted relay or capacitor, the compressor will start, and the overload protector will open.
- With an open or weak capacitor, the compressor will start and run. The compressor, however, will be operating at reduced efficiency of energy usage.

## Compressor Electrical Check

If the compressor will not run, make a voltage check across the power lead terminals on the PTC Relay. (See Figure C4.)

The voltmeter should show line voltage if the thermostat knob is in normal operating position and not in the OFF position. If this check does not show a live circuit, the electronic control system wiring should be checked for loose and/or broken connections.

You can jump from J42 to J41 with a piece of wire as a temporary bridge. If the compressor starts and runs with the bridge, the control thermostat is at fault and should be replaced.

If the voltage check shows power supply at the PTC Relay terminals, use a test cord to check the compressor.

If the compressor does not start and run with the test cord, check the line voltage to see if it is 115 volts  $\pm$  10% (104 - 126). If voltage is correct and the compressor will not start and run, replace the compressor.

If the compressor starts and runs with the test cord, replace the PTC Relay.

## PERIMETER AND MULLION HOT TUBE

To reduce the possibility of condensation forming on the exterior of the cabinet in high humidity areas, units are equipped with a one piece perimeter and mullion hot tube which is part of the refrigeration system. No electric heaters are used. Refer to the Refrigeration System Section for more information.

# 18 Section C - Electrical Components

## EVAPORATOR FAN & MOTOR ASSEMBLY

The fan and motor assembly are located behind the freezer compartment air duct directly above the evaporator in the freezer compartment.

The fan is a 12 VDC suction type, pulling air up through the evaporator and blowing it through the freezer and refrigerator compartments.

### NOTE

If the fan motor is running when the freezer door is opened, the speed will change from HIGH (2700 RPM) to LOW (2000 RPM).

On current production models, the fan blade is not adjustable and is designed to be pressed onto the motor shaft until it bottoms out against the stop at the front of the fan blade.

### To Remove Evaporator Fan Motor

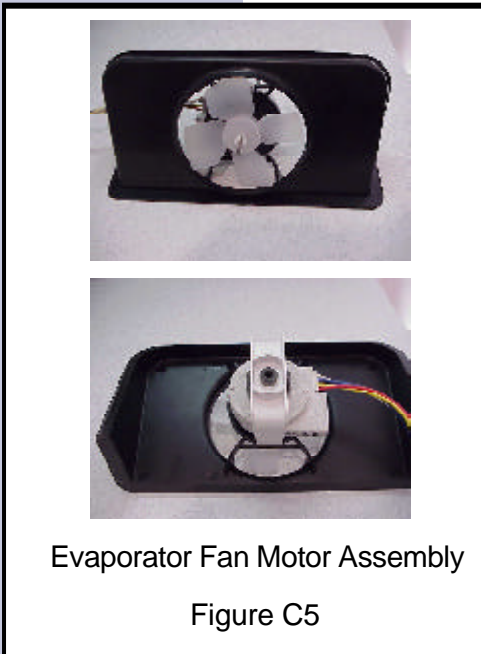

1. Disconnect refrigerator from electrical supply.
2. Remove freezer section bottom shelves and baskets.
3. Remove four screws from evaporator cover and remove the cover.
4. Remove the two bottom screws on evaporator air duct cover. This will allow you to pick the cover up to gain access to the fan assembly.
5. Disconnect connector. Evaporator fan motor assembly can now be pulled free.
6. Remove back bracket holding fan motor by pushing in and releasing tabs.
7. Remove fan blade and slinger washer.
8. Pull evaporator fan motor free.
9. Remove rubber bushings from each end of motor and transfer to new motor.
10. Reverse procedure to complete repairs.

### NOTE

The Slinger washer on the fan motor shaft must be adjusted to within 1/16" to 1/8" from motor to prevent water from entering motor bearing. When replacing the fan blade, press the blade onto the motor shaft until the blade bottoms out on the shaft.

## DEFROST THERMOSTAT

The defrost thermostat is a temperature sensing device. Wired in series with the electronic control board and the evaporator defrost heater, it senses the rise in evaporator temperature during a defrost cycle and cycles the defrost heater off after all frost is melted. It is calibrated to permit a defrost cycle only when the temperature is below a preset temperature. The contacts in the defrost thermostat are set to open at 47°F and close at 25°F.

### To Test The Defrost Thermostat

1. Measure resistance across two thermostat leads at connector plug. At room temperature, resistance should be infinity. The contacts are open.
2. Place a couple ice cubes on sides of thermostat. After a few seconds, thermostat should reset.
3. Measure resistance again. This time, reading should be 0. Contacts have closed.
4. If you get resistance readings that differ from this procedure, replace defrost thermostat. Contacts are probably burnt.

### To Remove The Defrost Thermostat

1. Disconnect refrigerator from electrical supply.
2. Remove freezer section bottom shelves and baskets.
3. Remove ice container and rail assembly. The multiconnector at the back of the rail assembly must be disconnected before rail assembly will come free.
4. Loosen two screws holding ice maker to right side of compartment just enough to lift ice maker free. The multiconnector must be disconnected before ice maker will come free from compartment.
5. Remove two rail assembly supports (two screws on each one).
6. Remove four screws from evaporator cover.
7. Remove five screws on evaporator air duct cover.
8. Cut two leads coming from thermostat close to base. You must leave enough wire coming from connector to allow for splicing in new thermostat.

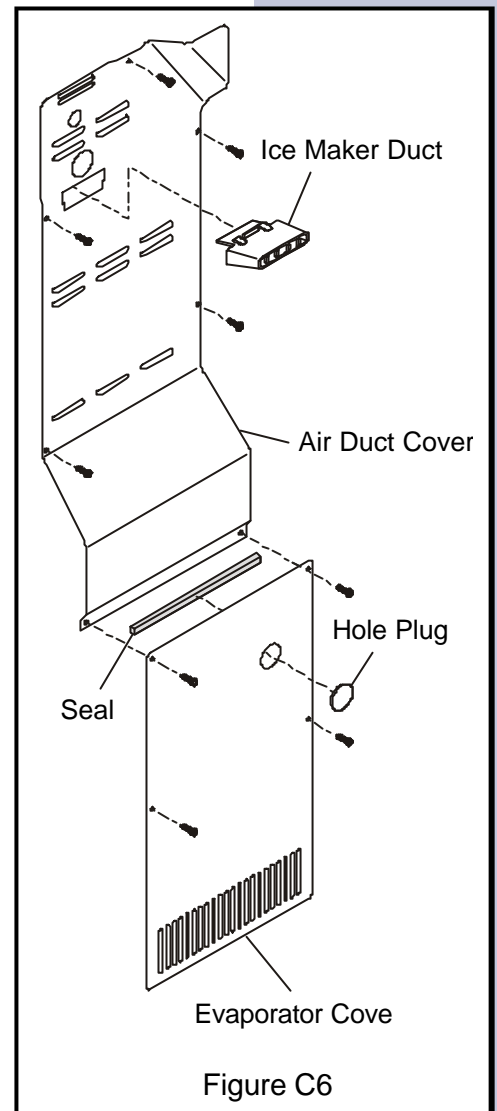

## 20 Section C - Electrical Components

9. Remove faulty thermostat.

### NOTE

The Defrost Thermostat Replacement Kit comes with a new thermostat, two solderless connectors and two pieces of heat shrink to allow for splicing the new thermostat to the connector plug.

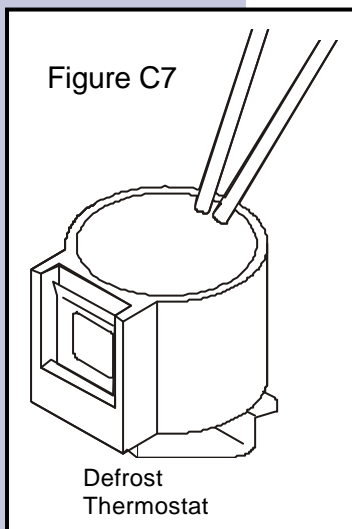

10. Crimp the two solderless connectors to the two leads on the new thermostat.
11. Slip the two pieces of heat shrink onto the two leads coming from the connector plug.
12. Crimp the two solderless connectors to the two leads coming from the connector plug.
13. Slip the heat shrink over the solderless connectors and heat that area with a heat gun until the heat shrink is tight around the solderless connectors.
14. Hook the thermostat back on the evaporator near or at the same place it was before.
15. Reverse Steps 1 - 7 to complete repairs.

## DEFROST HEATER

The defrost heater is a radiant “U” shaped resistance heater, rated at 450 watts. The defrost heater is energized during that period of the cycle when the defrost thermostat contacts are closed.

The length of time the heater is energized depends on the amount of frost accumulation on the evaporator.

### How To Remove The Defrost Heater

1. Disconnect refrigerator from electrical supply.
2. Remove freezer section bottom shelves and baskets.
3. Remove ice container and rail assembly. The multiconnector at the back of the rail assembly must be disconnected before rail assembly will come free.
4. Loosen the two screws holding ice maker to right side of compartment just enough to lift ice maker free. The multiconnector must be disconnected before ice maker will come free from compartment.

# Section C - Electrical Components

5. Remove two rail assembly supports (two screws on each one).
6. Remove four screws from evaporator cover.
7. Remove five screws on evaporator air duct cover.
8. Disconnect two leads to defrost heater.

## NOTE

This is a good time to test the heater. Check resistance of defrost heater using a multimeter. Resistance should be very close to 30 ohms. Replace defrost heater if resistance readings are out of range.

9. Unclip ground wire hooked to drain trough.
10. Remove screw holding evaporator bracket through drain trough to cabinet.
11. Remove rivet holding bracket to trough and set bracket aside for reuse.
12. Remove screw holding drain trough to cabinet .
13. Lift up and pull evaporator and drain trough out at bottom.

## NOTE

Use caution not to damage suction line or cap tube.

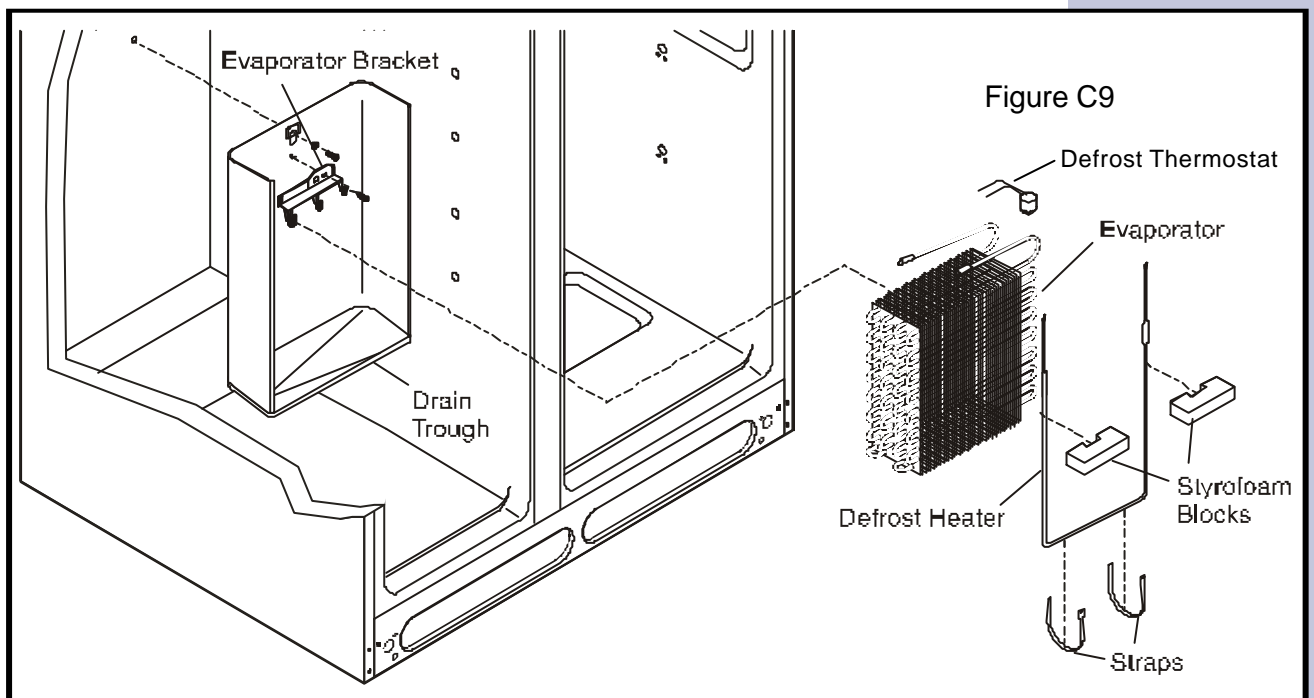
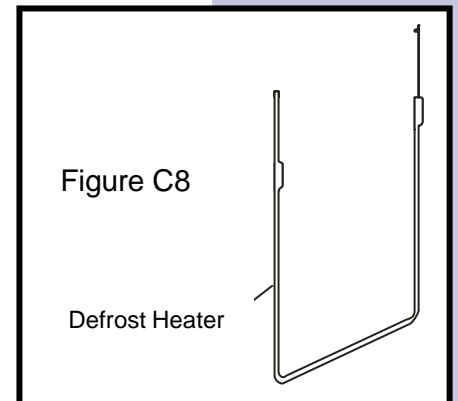

## 22 Section C - Electrical Components

### Defrost Heater (Cont.)

- Slide drain trough off evaporator.
- Remove retainer clamp from bottom of evaporator holding heater in place.
- Grab heater from bottom and pull free of evaporator. It's very snug so you'll need to use a little force.
- Replace with new defrost heater.
- Re-assemble in reverse order.

## ELECTRONIC CONTROL SYSTEM

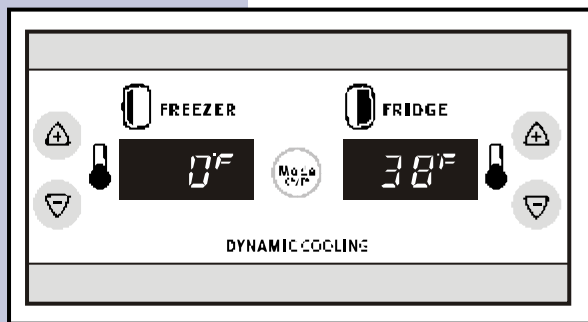

### Damper Assembly

Motorized door (+12 VDC) located between the freezer section and the fresh food section of the refrigerator. The door will open to a certain position when there are refrigeration requirements in the fresh food section. The damper motor, which positions the door, is a 12 VDC, 2 phase, bipolar stepper motor. See Diagram A.

### Freezer Temperature Control

An electronic thermostat regulates the temperature of the frozen food section. A Negative Temperature Coefficient Thermistor monitors freezer compartment temperature. Loads controlled at the compressor, condenser fan and evaporator fan motor enabling and speed. See Diagram A.

### Fresh Food Temperature Control

An electronic thermostat regulates the temperature of the fresh food section. A Negative Temperature Coefficient Thermistor monitors fresh food compartment temperature. The damper motor (position) and evaporator fan motor enabling and speed are controlled by the electronic control. See diagram A.

### Defrost Heater

A 450 watt heating element (115 VAC) located in the evaporator assembly to melt frost during the defrost cycle. The defrost heater is connected to the NO contact of a relay. Defrost Heater operation is detected and internally monitored by the microprocessor. See diagram A.

## Defrost Termination Thermostat (DTT)

Bi-metal disc thermostat attached via a clamp to the evaporator tubing. During the defrost cycle, the device is a closed circuit between the defrost heater and Neutral. The DTT is designed to open at a predetermined temperature ending the defrost cycle

## Standard Compressor

Motorized pump (115VAC) that creates the high and low pressures required for heat exchange. The Standard Compressor is controlled by a relay.

## Evaporator Fan

Motorized Fan (12 VDC) that circulates freezer and fresh food section air. The evaporator fan motor speed is controlled via a +12 VDC circuit.

### NOTE

If the fan motor is running when the freezer door is opened, the speed will change from HIGH (2700 RPM) to LOW (2000 RPM).

## Condenser Fan

Motorized Fan (115 VAC) that circulates air through the condenser coils. Either a Relay or Triac, depending on compressor used, controls condenser Fan Motor.

## Fresh Food Door Sensor

Magnetically activated reed switch. Switch will detect Fresh Food Door state.

## Air Filter

Motorized Fan (12VDC) that circulates air through a filter in the Fresh Food Section. The Filter Fan Motor is controlled via a power transistor. (Not on all models.)

## Sensors

Negative Temperature Coefficient Thermistor. ( $10k\Omega \pm 2\%$  @  $25^{\circ}\text{C}$ .)

## Fresh Food Lights

Fresh Food Lights are enabled and disabled depending on the Fresh Food Door Sensor state. Light on maximum is 15 minutes. Interior lights will shut off after 15 minutes if the door is left open. Closing and re-opening the door will reset the sequence.

# 24 Section C - Electronic Controls

---

## Alarm

Audible Transducer (Piezo)

## Control, Main Board

Power Supply ... AC Input Voltage – 115 V AC @ 60 Hz.

## Control, User Interface

Power Supply ... Input - 5VDC (from Main Board)

## Numeric Display

Version A ... 2 digit, 7 segment numeric with degrees symbol, minus sign segment and a 4 segment character to represent F and C (magnetically activated reed switch that detects Fresh Food Door state).

Version B ... 1 digit, 7 segment numeric. Fresh Food Door Sensor (magnetically activated reed switch that detects Fresh Food Door state).

## Fahrenheit & Centigrade Temperature (Some models)

Allows customer to change temperature readings from Fahrenheit to Centigrade and back.

## Showroom Setting

Active functions Displays:

- Freezer/Fresh Food Temperature keys
- Fresh Food Lights Alarm Key (Key Tone ONLY)
- Air Filter Key (Key Tone and Green LED toggles on and off)
- All other functions are disabled including alarm(s) enabling.

## NOTE

The term POR (Power On Reset) appears many times in this section of the Service Manual. POR simply means to remove the power cord from the electrical outlet, wait a few seconds, then plug the power cord back into the receptacle.

---

## ALARMS AND SIGNALS

### Temperature Alarm

Enabling is automatic and started at the time product is plugged in POR (power on Reset) but is delayed until actual Freezer temperature = Freezer temperature set point and actual Fresh Food temperature = Fresh Food temperature set point. Once set points are reached, Alarm LED (Green) will come ON, steady state, indicating Alarm is active.

### Alarm Condition

Alarm is enabled and active. Temperature parameters are within tolerances. Alarm LED (Green) is ON and steady state.

### Reset Button

Press once to reset any Alarm condition. Alarm LED (steady green).

Press and hold **reset** 3 seconds (you will hear one beep) to turn all alarm functions Off.

Press and hold **reset** 3 seconds (you will hear one beep) to turn all alarm functions On.

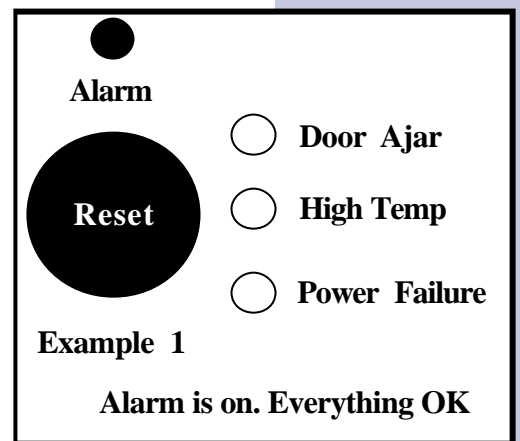

## NOTE

When POR (power on reset) The Alarms are delayed (180 Minute maximum) until set points temperatures are reached.

Default at POR (power on reset) is On.

### Door Ajar LED (flashing green)

If either door is open for 5 minutes, this light blinks and control beeps. Condition is reset if the opened door is closed or reset button is pressed.

Fresh Food and/or Freezer doors have been open for at least 5 minutes. (See Example 2.)

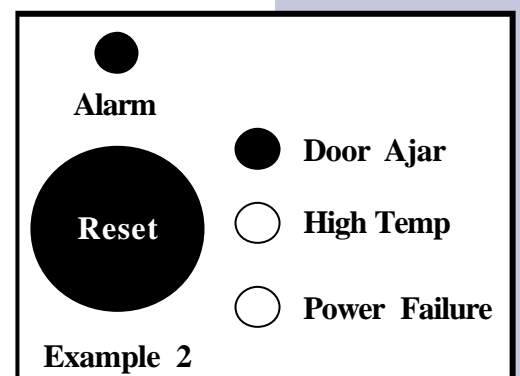

# 26 Section C - Electronic Controls Door

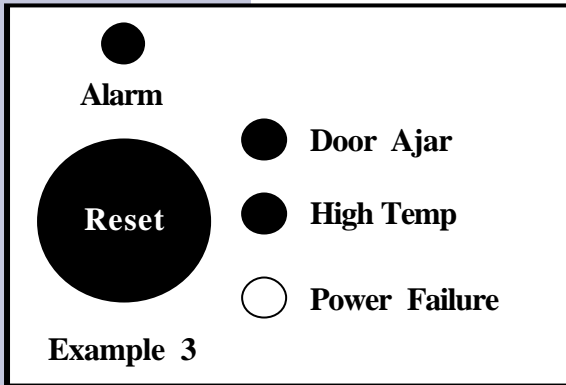

## Door Ajar & High Temp

Fresh Food and/or Freezer doors have been open for at least 5 minutes and temperatures have exceeded recommended limits. (See Example 3.)

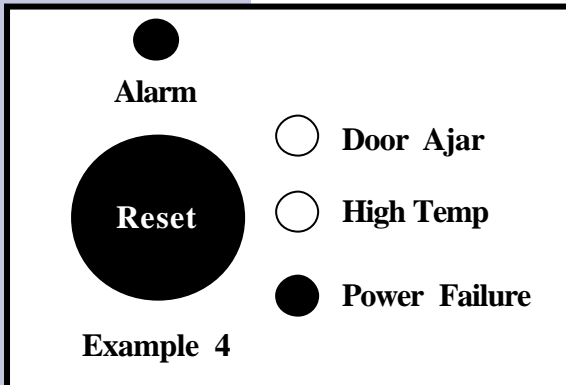

## Power Failure (flashing yellow)

If power fails, this light blinks.

Power has been off. (See Example 4.)

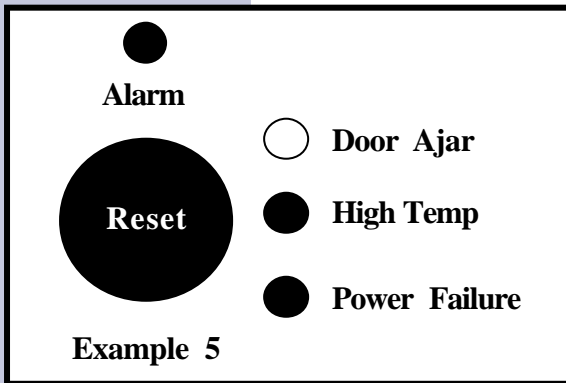

## Power Failure & High Temp

Power has been off and temperatures have exceeded recommended limits. (See Example 5.)

### NOTE

If the user unplugs the unit and the setpoints have been reached, when the product is plugged back in (POR) the "Power Off" indicator will be on. If the user has the product unplugged long enough to cause a unsafe temperature condition, the "High Temp" indicator will also be on when the product is plugged back in.

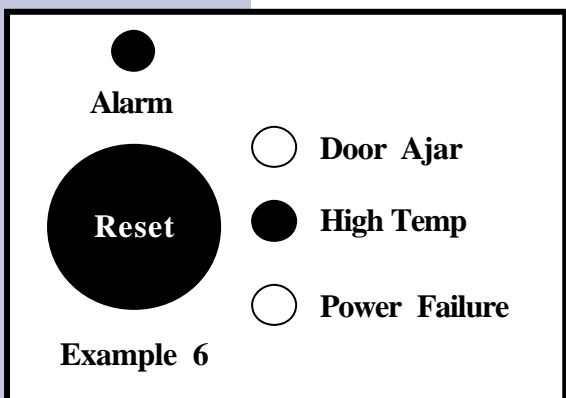

## High Temp

Temperatures have exceeded recommended limits. (See Example 6.) See Owners Manual.

## Alarm OFF

Alarm has been turned Off by user. (See Example 7. )

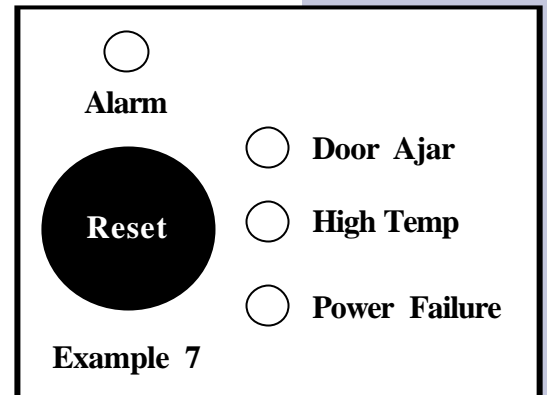

## SHOW ROOM SETTING

### Activation

Press and hold Fresh Food Temperature UP (WARMER) Key while pressing the fresh food temperature DOWN (COLDER) key 3 times within 5 seconds. Both displays will flash “0” for 10 seconds. While the displays are flashing, press the Freezer Temperature UP key to confirm activation

### Deactivation

Mode automatically deactivates at a power on reset

### Active Function Displays

- Freezer/Fresh Food Temperature Keys
- Fresh Food Lights
- Alarm Key. Key Tone ONLY
- Air Filter Key. Key Tone and green LED toggles On & Off.
- All other functions are disabled including alarm(s) enabling

### Fresh Food Lights

Fresh Food Lights are enabled and disabled depending on the Fresh Food Door Sensor state. Light on maximum is 10 minutes. Interior lights will shut off after 10 minutes if the door is left open. Closing and re-opening the door will reset the sequence.

### NOTE

The “Show Room” mode doesn’t recognize Alarm/Power Off conditions during activation.

### Change Between Fahrenheit and Centigrade (on some models)

To change form Fahrenheit to Centigrade, press the Mode key.

To change form Centigrade to Fahrenheit, press the Mode key.

### Advance Into Defrost Cycle Manually

#### Activation

Press and hold Freezer Temperature UP (WARMER) Key while pressing the fresh food temperature DOWN (COLDER) key 5 times within 6 seconds. This will advance the processor into defrost cycle.

#### Deactivation

Press and hold Freezer Temperature UP (WARMER) Key while pressing the fresh food temperature DOWN (COLDER) key 5 times within 6 seconds. This will advance the processor out of defrost cycle. Or just let the refrigerator alone and it will go through a normal defrost cycle and start running after defrost limit switch has turned off the heater and the controller has allowed for a normal drip time.

## OPERATION - UPDATED REVISION L

### User Interface – Ver. A (Two Position Read Out for Freezer and Food Compartment)

#### Freezer

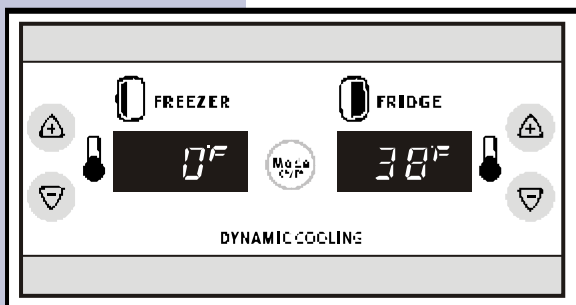

Temperature UP key increments temperature setting up one degree, F or C, for each key press. Setting Upper Limit = +6°F (-14°C).

Temperature DOWN key decrements temperature down setting one degree, F or C, for each key press. Setting Lower Limit = -6° F (-21°C). Each key press (Temperature UP or DOWN) displays temperature setting. Actual temperature will be displayed after 10 seconds of no key entries and during normal operation.

Displays are off when Fresh Food Door is closed. Communications remain active. Default = 0°F (-18°C).

## Fresh Food

Temperature UP key increments temperature setting one degree, F or C, each key press. Setting Upper Limit = 47°F (8°C).

Temperature DOWN key decrements temperature setting one degree, F or C, each key press. Setting Lower Limit = 33°F (1°C).

Each key press (Temperature UP or DOWN) displays temperature setting.

Actual temperature will be displayed after 10 sec. of no key press and during normal operation.

## Temperature Alarm

Pressing the “Alarm” key activates, deactivates and resets the Alarms.

## Air Filter Control (Not on all Models)

Pressing the “Air Filter” key activates the Fresh Food Filter and turns the Air Filter LED (tri-color) on. Press “Filter” key again to deactivate and turn the Air Filter LED (tri-color) off.

When activated, the Air Filter Fan Motor will run continuously until it is turned off.

Air Filter Fan Motor run time is monitored during activation as to determine and display Air Filter Status via LED color.

- Green 0-3600 hours run time.
- Amber 3600-4344 hours run time.
- Red. 4344 hours or more run time.

Air Filter Status is reset by pressing and holding “Air Filter” key for 3 seconds.

## Fast Freeze/Fast Ice Mode

### Fast Freeze

Freezer Temperature Set Point is adjusted to -6°F when this option is selected from the IWD (Ice and Water Dispenser). Set Point will return to the previous setting after the mode terminates in 16 hours.

### Fast Ice

Freezer Temperature Set Point is adjusted to -6°F when this option is selected from the IWD. Set Point will return to the previous setting when the mode terminates in 12 hours.

### Over Temperature Shut Off

Compressor operation is terminated at ambient temperatures over 85°C (185°F).  
Compressor operation continues at 65°C (149°F).

### User Interface - Version B (One position read out for freezer and food Compartment)

#### Freezer

Temperature Colder key increments setting one number each key press. Setting  
Upper Limit = 9

Temperature Warmer key decrements setting one number each key press. Setting  
Lower Limit = 0 (Off).

#### Number Setting to Temperature Conversion

0 = Off (All Loads. Damper Closed). Displays = "0".

1 = +6°F (-14°C).

2 = +4 (-15.5°C).

3 = +3 (-16°C).

4 = +2 (-17°C).

5 = 0°F (-18°C).

6 = -2°F (-19°C).

7 = -3°F (-19.5°C).

8 = -4°F (-20°C).

9 = -6°F (-21°C).

Displays are off when Fresh Food Door is closed. Communications remain active.  
Default = 5.

#### Fresh Food

Temperature Colder key increments setting one number each key press. Upper  
Limit = 9

Temperature Warmer key decrements setting one number each key press. Lower  
Limit = 1.

---

## Number Setting to Temperature Conversion

- 1 = 47°F (8°C).
- 2 = 44°F (6.5°C).
- 3 = 43°F (5.5°C).
- 4 = 41°F (4°C).
- 5 = 37°F (3.5°C).
- 6 = 36°F (3°C).
- 7 = 35°F (2.5°C).
- 8 = 34°F (2°C).
- 9 = 33°F (1°C).
- Default = 5.

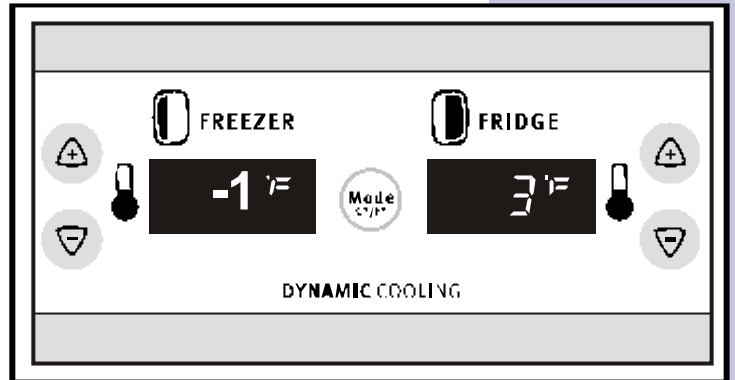

# 32 Section C - Diagrams

## Diagram A - Control System

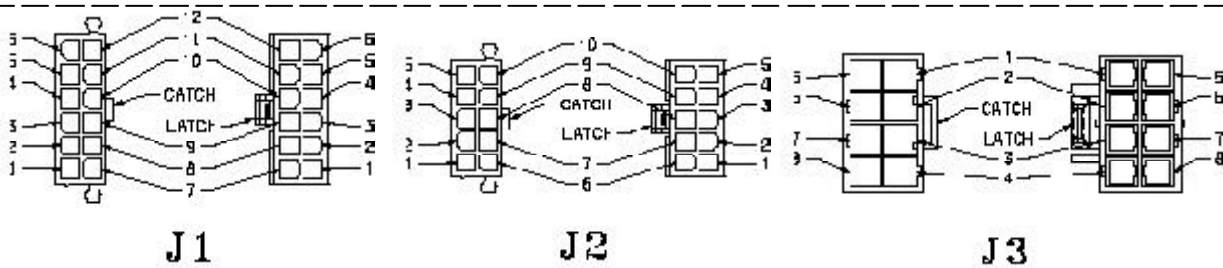
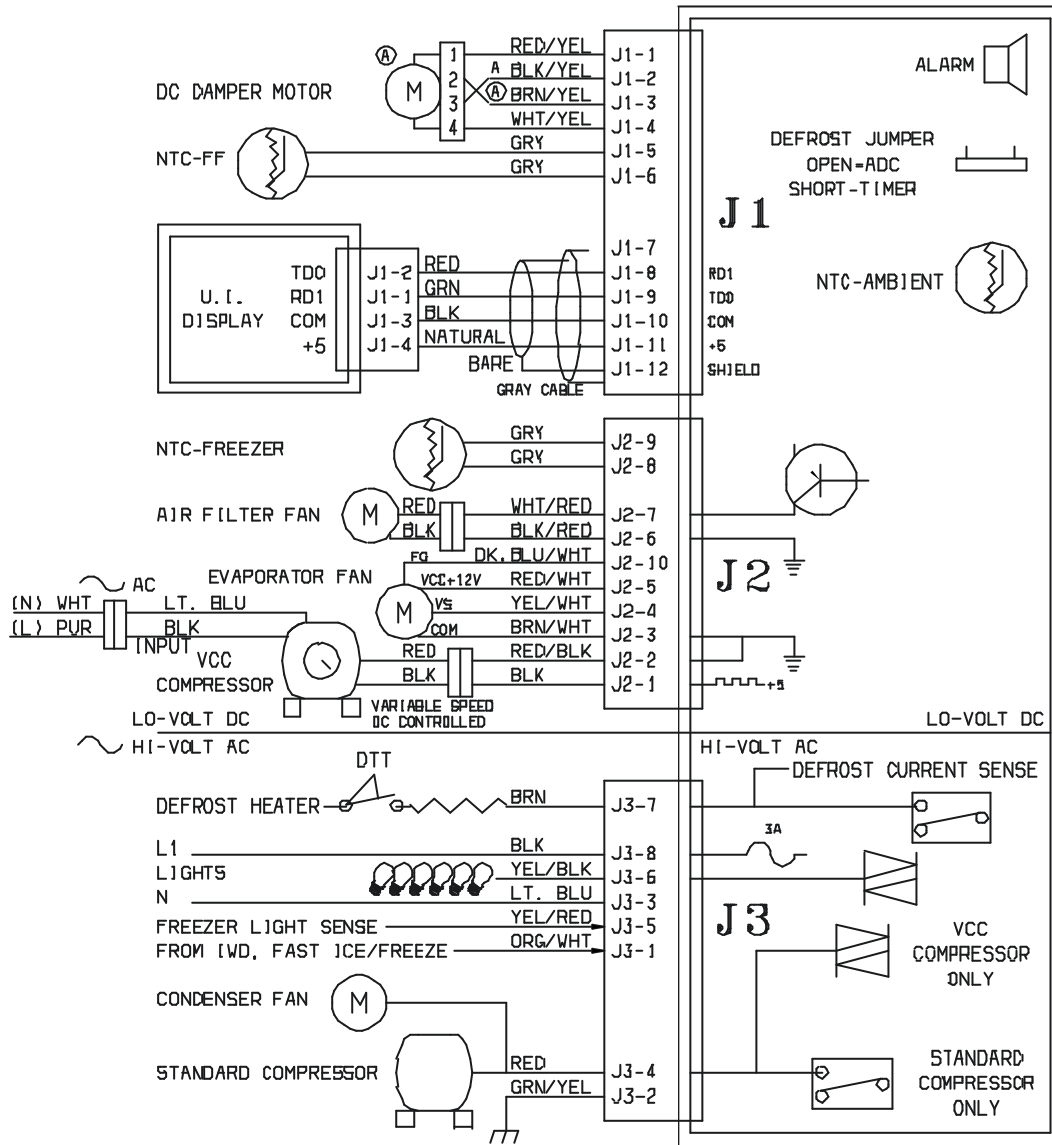

## Diagram B Controller, User Interface Board Reference ONLY See Drawing

### Version A

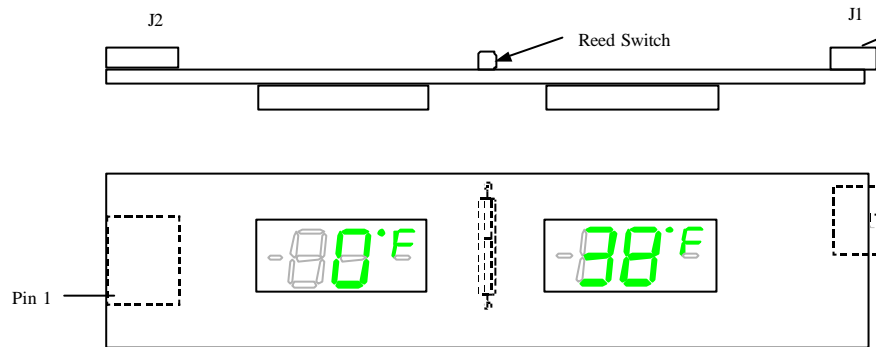

### Version B

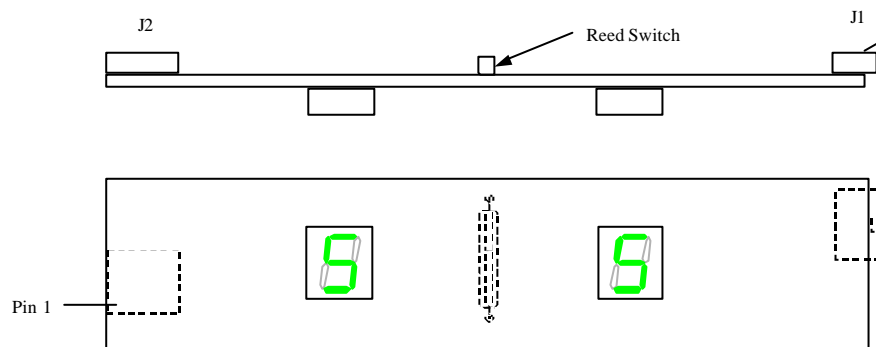

# 34 Section C - Wiring Diagrams

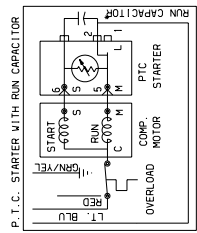
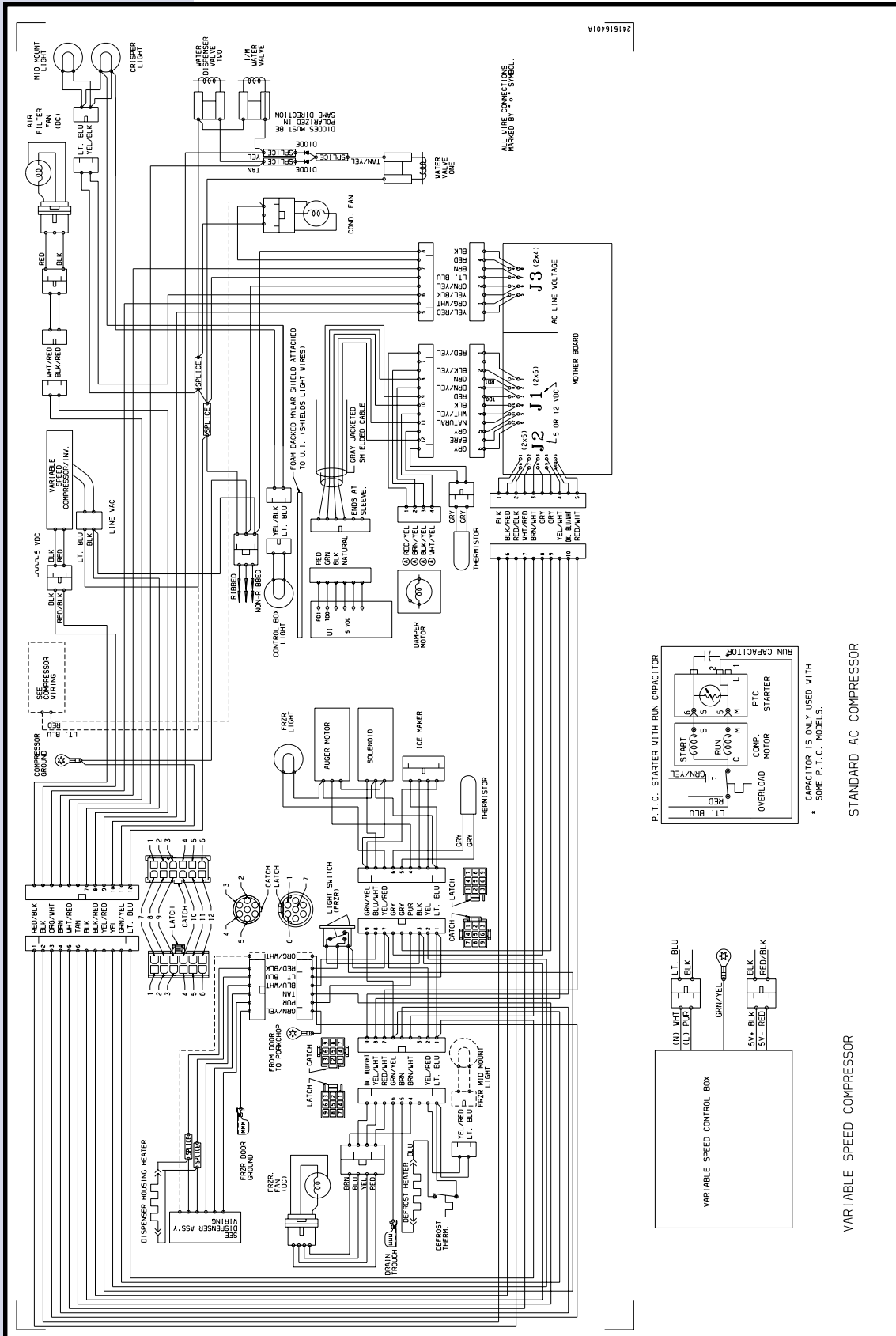

\* CAPACITOR IS ONLY USED WITH SOME P.T.C. MODELS.

STANDARD AC COMPRESSOR

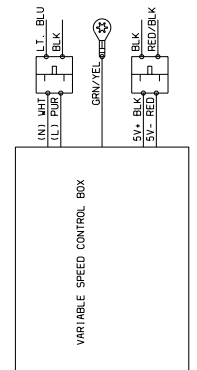

VARIABLE SPEED COMPRESSOR



# 36 Section C - Performance Data

PERFORMANCE DATA NO LOAD AND NO DOOR OPENINGS AT MID-POINT CONTROL SETTING				
Type A with Run/Start Capacitor	85°F (18°C) Ambient		90°F (32°C) Ambient	
Operating Time	32 TO 40%		55 TO 65%	
Freezer Temperature	0° TO 4°F -18° to -16°C		-1° TO 3°F -18° to -16°C	
Refrigerator Temperature	34° TO 39°F 1° to 4°C		34° TO 39°F 1° to 4°C	
Low Side Pressure (cut-in)	5 to 12 psig 34 to 83 kPa		5 to 12 psig 34 to 83 kPa	
Low Side Pressure (cut-out)	-2 to 2 psig -14 to 14 kPa		-2 to 2 psig -14 to 14 kPa	
High Side Pressure (last 1/3 of cycle)	90 to 115 psig 621 to 793 kPa		130 to 155 psig 896 to 1069 kPa	
Wattage (last 1/3 of cycle)	120 to 150		130 to 160	
Amps (running)	1.0 to 1.4		1.1 to 1.5	
Base Voltage	115 vac (127 vac max)		115 vac (127 vac max)	
DEFROST SPECIFICATIONS				
Cabinet Size	Thermostat		Heater	
	Cut-In	Cut-Out	Watts	Ohms
23'	25°F -4°C	47°F 8°C	450	30
Electronic Timer – (ADC) Defros 24 minutes every 6 to 96 hours of compressor run time.				
CONDENSER FAN MOTOR				
Watts	RPM		Amps	
2.8	950 CW Opposite Shaft		.1 Running	
ICE MAKER SPECIFICATIONS				
Electrical	115 vac (127 vac max)			
Thermostat	Opens at 48°F (9°C)		Closes at 15°F (-9°C)	
Heater Wattage	85			
ICE MAKER CONNECTOR PLUG CONNECTIONS				
Wire Number	Wire Color		Connects to:	
1	Green/Yellow		Ground	
2	Yellow		Water Valve	
3	Black		Line	
4	Light Blue		Neutral	

## SERVICE DIAGNOSTIC MODE - SIGMA ELECTRONIC CONTROL

With a series of key presses, a service technician will be able to view data, via the display and exercise loads to help troubleshoot the product. Following is a list of capabilities.

### View

- Firmware Version (version of software that is running in the control system)
- Minimum, maximum and average Freezer temperatures, last 24 hours
- Minimum, maximum and average Fresh Food temperatures, last 24 hours
- Indicate an open or shorted sensor condition
- Indicates if defrost occurred in the last 72 hours
- Number of defrosts, last 72 hours
- How long the last defrost was
- Number of compressor cycles, last 24 hours
- % Compressor Run Time, last 72 hours
- Average Compressor Speed (Variable Speed Compressor).

### Test

- Manually test sensors.
- Run evaporator fan at high and low speeds
- Operate damper to full open, full close and mid positions.
- Turn defrost heater on.
- Turn compressor on.

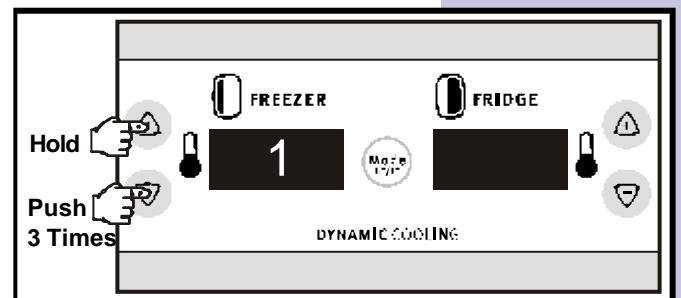

To enter the test mode, press and hold the Freezer Temperature UP (Warmer) key while pressing the Freezer Temperature DOWN (Colder) key 3 times within 5 seconds.

The freezer display will show "1". The fresh food display will be blank. Each press of the freezer temperature up (Warmer) or the freezer temperature DOWN (Colder) key will step you through the service menu tests, "1" through "8". Each press of the fresh food temperature UP (Warmer) or fresh food temperature DOWN (Colder) key will step you through variables of each test.

# 38 Section C - Service Diagnostics

## NOTE

Note: If you are in test 1 and press the freezer UP key it will go to test 8. If you are at the start of test 1 and press the food compartment UP key it will beep at you.

## Deactivation

Press and hold Freezer Temperature “UP” key for 5 seconds until you hear one beep. This deactivates the Service Mode. Mode automatically deactivates after 5 minutes of no key entry.

## Service Test Menu

### Test 1 - Firmware Version

Variable 1. Display main board software version.

Variable 2. Display user interface software version.

### Test 2 - Evaporator Fan Test

Variable 1. Motor runs at high speed continuously until variable is exited. Display will show H for high speed.

Variable 2. Motor runs at Low speed continuously until variable is exited. Display will show L for low speed. High Speed is 2700 and low is 2000 RPM.

### Test 3 - Freezer temperature, last 24 hours. (Defrost temperature omitted)

Variable 1. Display Minimum Temperature (Coldest temperature)

Variable 2. Display Maximum Temperature (Warmest temperature)

Variable 3. Display Average Temperature

## NOTE

On products with two position read out in the freezer and food compartment the one or two digit temperature will appear in the food display to give you the test temperature.

On products with one position read out in the freezer and food compartment, the first number of the temperature will be constant for 1 second. The second number (if needed) of the temperature will flash twice in one second. It will alternate back and forth to give you the test temperature.

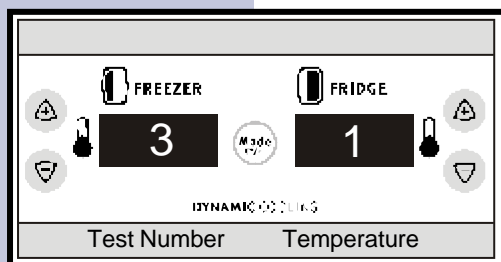
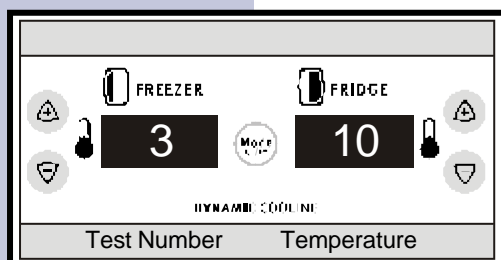
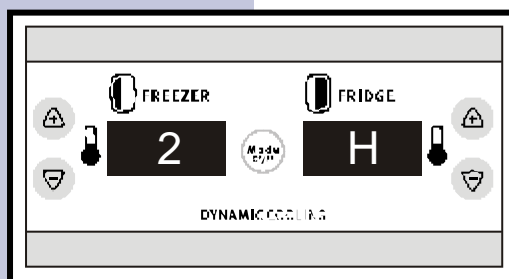

# Section C - Service Diagnostics 39

Variable 4. Freezer sensor circuit condition;

- Flash "1" Freezer sensor OK
- Flash "2" Freezer sensor open
- Flash "3" Freezer sensor shorted

Variable 5. Disables buffer to allow technician to place his finger on the freezer sensor and observe an immediate temperature rise.

## NOTE

The upper control limit is 4 degrees over set temperature.

**Test 4** Fresh Food temperature, Last 24 hours

- Variable 1. Display Minimum Temperature
- Variable 2. Display Maximin Temperature
- Variable 3. Display Average Temperature

## NOTE

On products with two position read out in the freezer and food compartment, a one or two digit temperature will appear in the food display to give you the test temperature.

On products with one position read out in the freezer and food compartment, the first number of the temperature will be constant for 1 second. The second number of the temperature will flash twice in one second. It will alternate back and forth to give you the test temperature.

Variable 4. Fresh Food sensor circuit condition will be displayed in Fresh Food Window:

- Flash "1" Fresh Food sensor OK
- Flash "2" Fresh Food sensor open
- Flash "3" Fresh Food sensor shorted

Variable 5. Disables buffer to allow technician to place his finger on the Fresh Food sensor and observe an immediate rise in temperature.

## NOTE

The upper control limit is 2 degrees over set temperature.

**Test 5** - Damper Motor is a 12 volt DC Stepper motor.

- Variable 1. Damper to full open
- Variable 2. Damper to mid position
- Variable 3. Damper to full closed

0	FULL OPEN
⊖	MIDDLE
—	CLOSED

The display will show the following symbols above to indicate the door position.

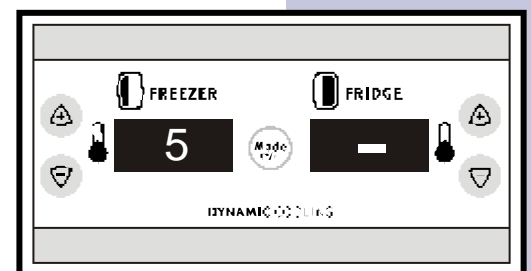
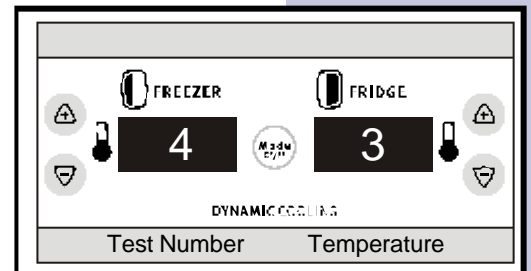
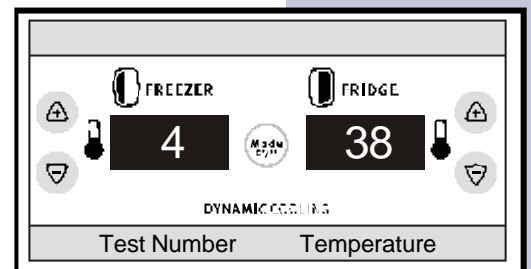

# 40 Section C - Service Diagnostics

## NOTE

Stepper motors require alternating polarities of DC current to operate. This is accomplished with a circuit on the main board. Applying straight 12 V DC to the damper motor will not make the motor run and it could damage the motor windings. Only test the damper motor through the refrigerator control system.

### Test 6 - Defrost

Variable 1. Number of defrosts, last 72 hours

Variable 2. Duration of last defrost heater on time in minutes.

Variable 3. Will turn on defrost heater.

If current flow to heater is sensed, the letter 'D' will be displayed. If no current flow is sensed, the letter 'D' will flash. This will continue until servicer advances to another test or 5 minutes have passed without a key entry.

## NOTE

If the defrost limit switch opens during the time the heater is on the D will change to a flashing D, indicating there is no current flow.

### Test 7 - Compressor and condenser fan on

Variable 1. Compressor run time percentage in last 72 hours

Variable 2. Number of compressor cycles last 24 hours

Variable 3. Average compressor speed (Variable speed compressor only) Speed displayed as a number between 16 and 45. Actual speed is times 100.

## NOTE

This test will display a "0" on models with standard speed compressors.

Variable 4. Run compressor and condenser fan motor. The display will flash the letter "C" when the compressor and condenser fan are running.

## NOTE

Diagram C on Page 41 will show key commands for service.

### Test 8 Default Settings / Clear Service Data

Variable 1. Display "1" Indicates default settings have been changed and/or there is service data in memory.

Variable 2. Display "0" Indicates Factory Defaults (resets temperature settings to 0 and 37° F) and service data memory cleared.

To reset temperatures to factory default, clear the service memory, and enable

# Section C - Service Diagnostics

the servicer to restart system recording new data, press and hold the fresh food UP (WARMER) key while pressing the fresh food DOWN (COLDER) key 3 times within 30 seconds.

## Manual Defrost

**Activation** - Press and hold Freezer Temperature UP (WARMER) Key while pressing the fresh food temperature DOWN (COLDER) key 5 times within 6 seconds.

**Deactivation** - Press and hold Freezer Temperature UP (WARMER) Key while pressing the fresh food temperature DOWN (COLDER) key 5 times within 6 seconds.

## Function

Initiates a normal defrost cycle. All other functions are disabled including alarm(s) enabling.

### NOTE

The refrigerator will come out of the defrost cycle on it's own.

**Show Room Mode** - See page 27

**Changing between Fahrenheit to Centigrade on the display** - See page 28

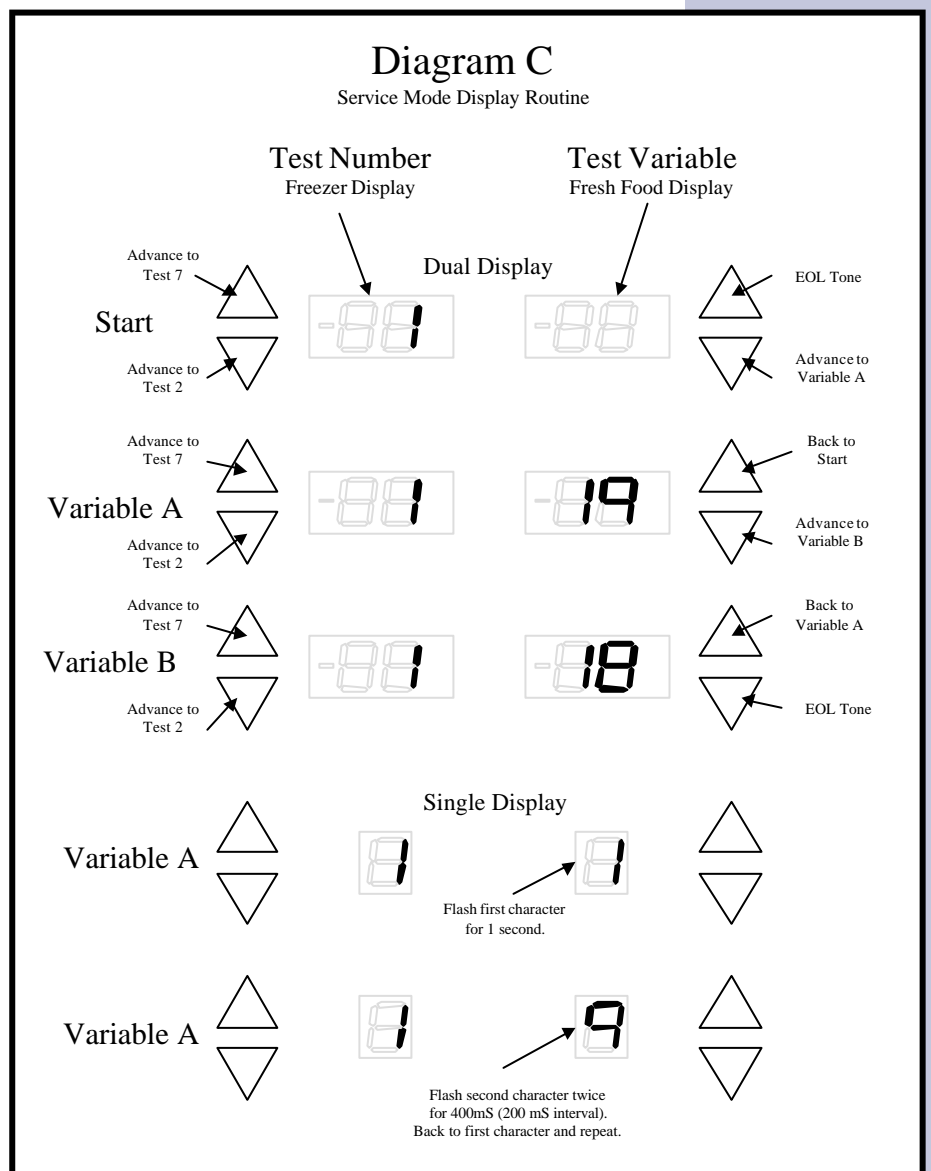

## 42 Section C - Removal & Installation

### CONTROL REMOVAL & INSTALLATION

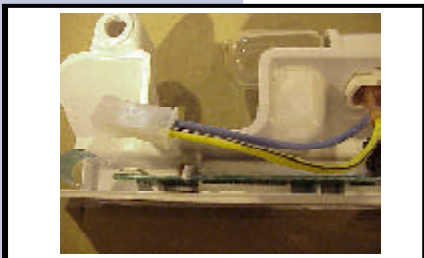

#### CAUTION

Before servicing any part of the control system the product must be unplugged, the fuse pulled or circuit breaker turned off to prevent damage to the the product the control system or personal injury to the

To service the control board, open the food door and remove the cover over the water lines going to the water filter.

Then remove the screws on the back of the control box. There are two directly behind the control, one at the back of the filter housing and one on the right side of the filter housing. This will allow the control box to drop down.

With the control box dropped down, there is one harness coming out of the top of the food liner and plugging into the control board. Unplug the control board and remove the control box.

With the control box removed there are two tabs to release and you must unplug the ribbon cable from the front membrane of the control board. The control board can now be lifted out of the control housing.

#### NOTE

When handling and/or replacing a control board, it is important for the technician to have a wrist ground strap on and connected to the cabinet or another grounding position to protect the board from damage form static electricity.

Reconnect ribbon cable and push the new control board down into place using caution not to damage the board on the retainer. With the board snapped all the way down in place, reinstall the control box in the top of the food compartment in reverse order from the removal instructions.

# Section C - Removal & Installation 43

To service the power board (Main power supply), open the food and freezer doors. Remove the kick plate from the bottom of the cabinet. Looking through the opening at the bottom of the cabinet on the left side you will see the plastic box containing the power board.

There is one screw in the middle of the front of the white plastic box holding the control board. Remove the screw and slide the control box forward. The back of the control box sits on a rail. Now the control box can be pulled out the front of the product.

This will give you access to the wiring connectors so you can disconnect the power board and remove the control box out the front of the refrigerator.

The new power board will come installed in the plastic box. This will help prevent shipping damage and help with the installation.

Start the control box into the opening and reconnect the wiring using caution to make sure they are all the way plugged in. Now you can push the control box back in place and reinstall the screw.

There is a 3 amp fuse mounted on the control board that is used to protect the board from voltage surges.

To replace the fuse, remove the control board, and lift the fuse out of the retainer.

To replace the damper, remove the cover by placing a small screwdriver in the slotted opening in the bottom and push up on the retaining tab. This will allow you to swing the bottom of the control box out and lift the top off the retainer.

With the cover removed, you can reach down the right (back) side of the damper control at the top and feel a release tab. Push out on the tab and tip the damper out from the top.

With the damper tipped out, release the tab in the center of the electrical connector and unplug the wire harness from the damper.

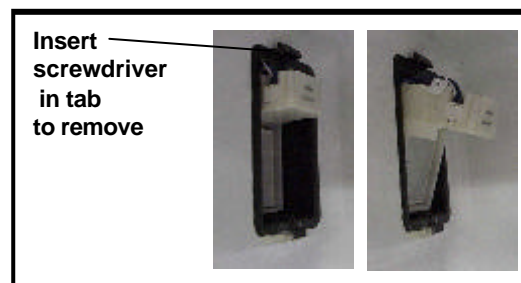
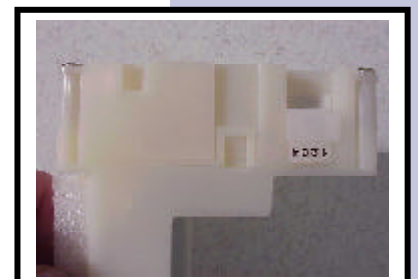
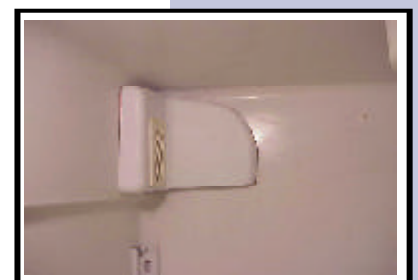
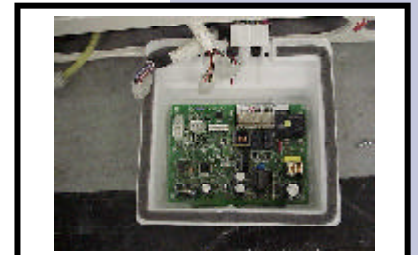

# 44 Section C - Removal & Installation

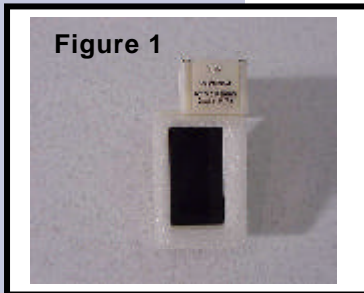

Now the damper can be removed from the product.

## NOTE

Stepper motors require alternating polarities of DC current to operate. This is accomplished with a circuit on the main board. Applying straight 12 V DC to the damper motor will not make the motor run and it could damage the motor windings. Only test the damper motor through the refrigerator control system.

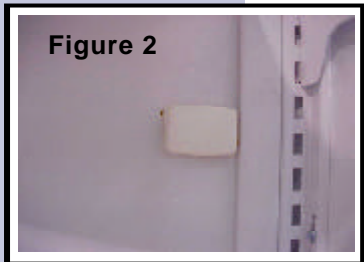

To replace the damper, make sure the damper door is closed all the way. Then follow the removal instructions in reverse order. Using caution, make sure you get the wiring connector pushed all the way in and make sure the seal on the damper connects with the liner, and the cover seal so we do not have any air leaks when the damper door is closed.

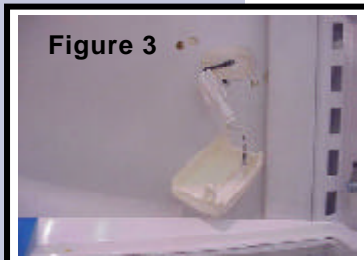

To test, set the control system into service test mode 2 (Evaporator fan motor test) and allow the fan to run on high speed. With a feather or small ribbon go around the cover over the damper on all sides and look for movement indicating an air leak. If the air leak is present you will need to remove and recheck seals and reinstall the damper.

The food compartment temperature sensor is located next to the right hand shelf support bracket in about the middle. See figure 2.

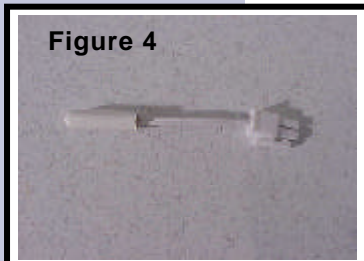

The cover over the temperature sensor can be removed by pulling straight out. This will gain you access to the sensor snapped into the bracket on the back. Pull the sensor out of the bracket and unplug it from the connector coming out of the back of the liner. See figure 3.

Snap the new sensor into the bracket, plug it into the connector and push the bracket straight back into the holes in the liner.

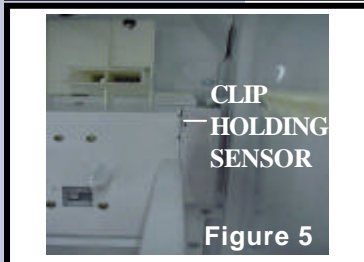

The freezer compartment temperature sensor is located inside the housing that supports the ice bucket and has the auger motor and solenoid mounted into it. See figure 5.

To replace, remove the ice bucket, then remove the two screws at the bottom of the housing holding the housing assembly to the rails attached to the liner. With the screws removed, lift the housing up about 1/2 inch and pull forward. Holding the housing assembly in one hand, you can reach over the assembly and unplug the wiring harness from the connector coming out of the back of the liner. Turn the assembly around and the sensor is in the top corner next to the foam block over the cube ice solenoid.

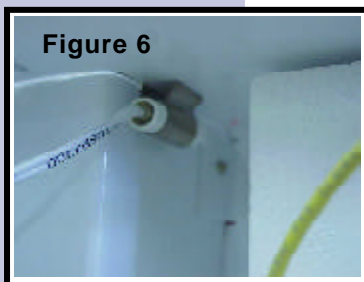

Remove the sensor from under the clip (see figure 6), disconnect from connector plug and replace. Reassemble in reverse order.

# Section C - Removal & Installation 45

---

## Food Compartment Light Switch

The food compartment light switch is a Magnetic Reed switch located on the control board at the top of the food compartment.

If the reed switch would fail, the control board will need to be replaced. Follow control board replacement instructions.

The magnet that operates the Reed Switch is located at the top of the food door inner door panel.

The magnet can be replaced by removing the screw located at the bottom of the bracket. Then lift the magnet and cover off the door panel. On some models, it will be necessary to remove the top bin to get to the magnet.

The bin will lift off in the same manner as the door bins. Lift straight up and out.

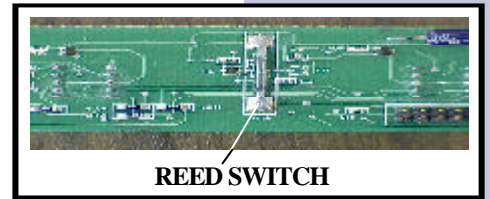

# 46 Section C - System Exploded View

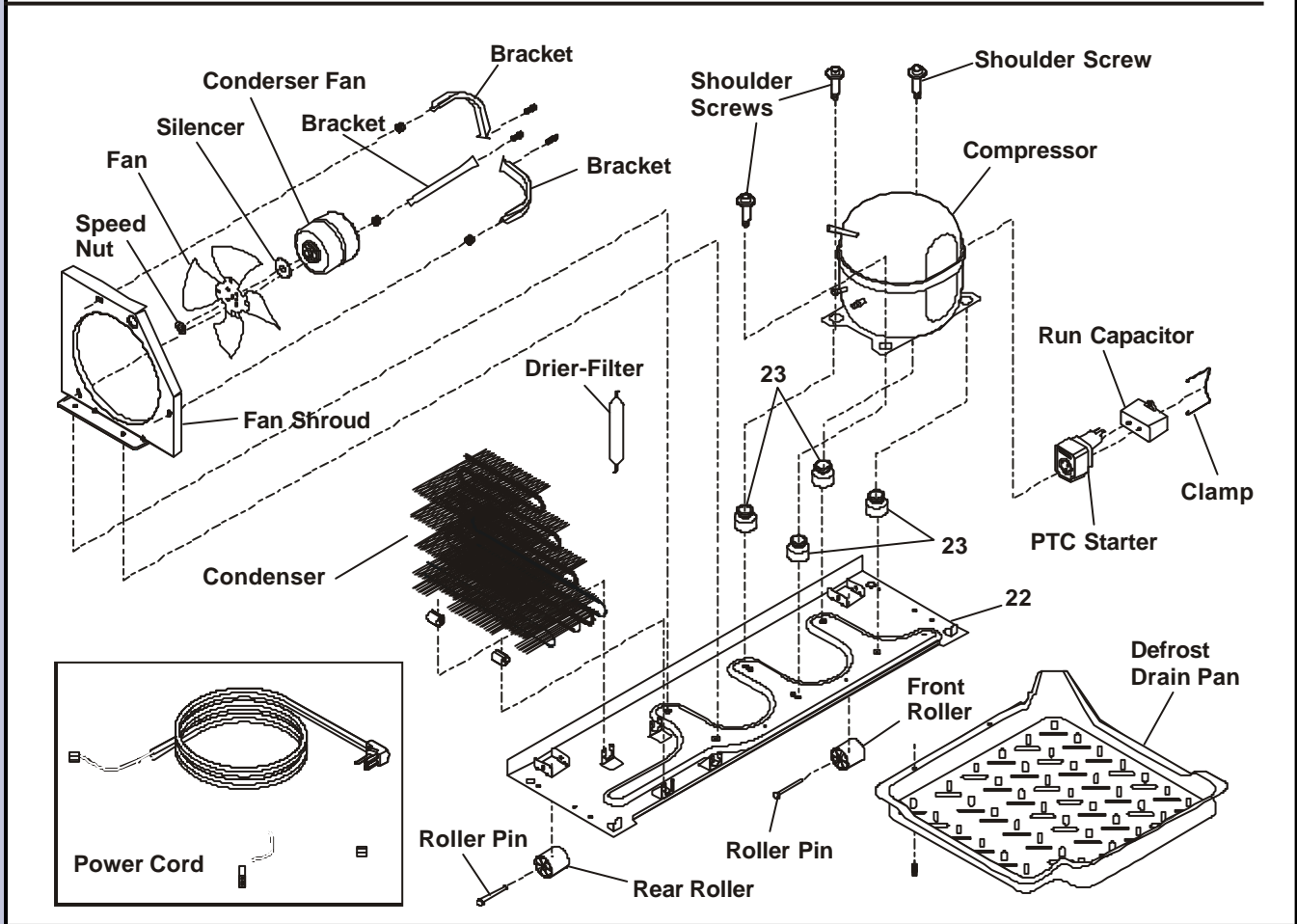
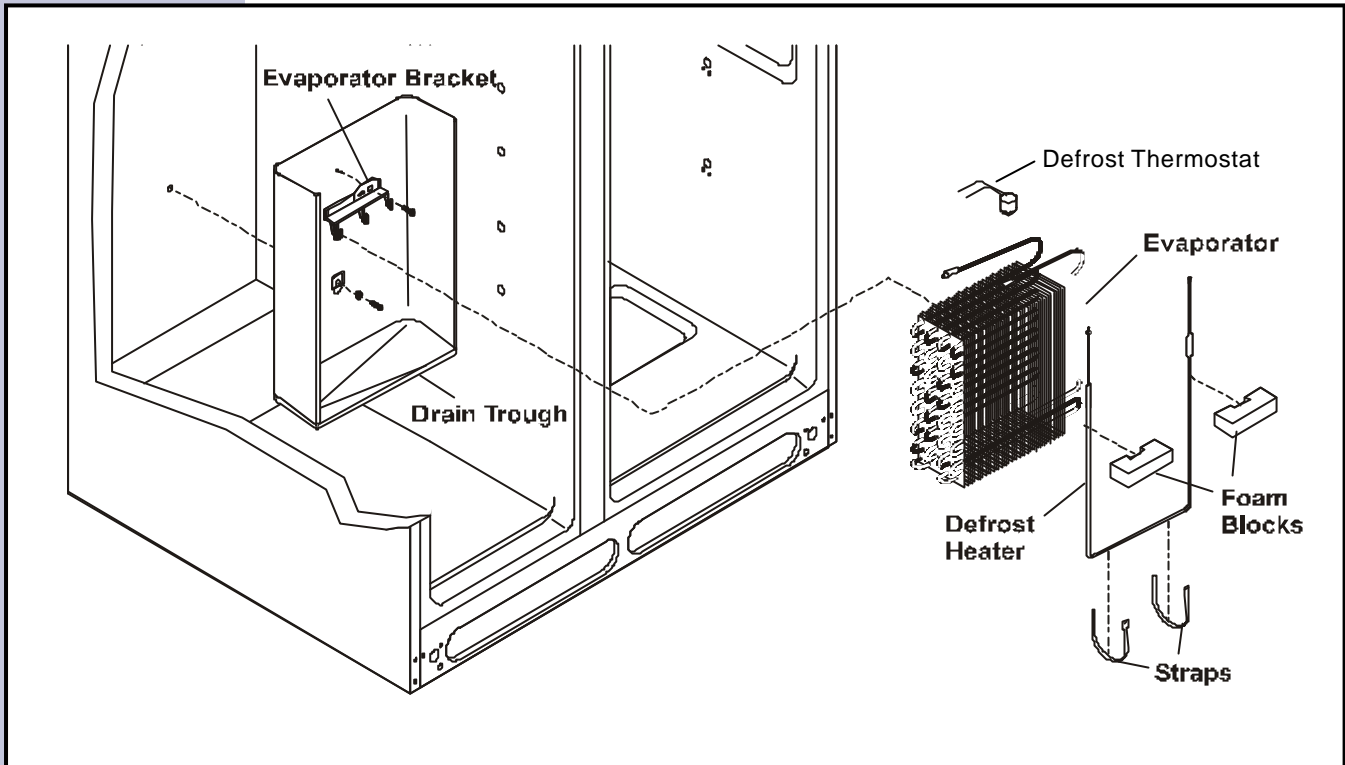

## AUTOMATIC DEFROST MODELS

### Principals Of Automatic Defrost Operation

All Counter Depth refrigerators operate on the principle that moisture or frost transfers or migrates to the coldest surfaces (evaporator) in the freezer compartment. For example, a small amount of water spilled in the freezer compartment will freeze immediately. However, this ice in time will evaporate and transfer to the colder surfaces of the freezer evaporator coil.

### Air Circulation Patterns

Automatic defrost models have a single evaporator in the freezer compartment, and have forced air cooling in the freezer and refrigerator compartments.

The “fin and tube” aluminum type evaporator is located on the lower back wall of the freezer compartment. A circulating fan (suction type) pulls air from the freezer compartment through the grill in the bottom of the freezer and from the refrigerator compartment through a duct located in the separating wall in the bottom rear left hand corner of the cabinet interior. The air is then drawn up through the fin and tubes of the evaporator surface. The cold air is forced into a fan cover and discharged into the top of the freezer and out the air discharge under the ice maker. See Figure D1. If the food compartment control is calling for cooling, the automatic damper in the top of the food compartment will open and allow cold air to enter the food compartment. If the food compartment calls for cooling but the fan is not running, the fan will start as soon as the damper is open and will continue to run as long as the food compartment or the freezer compartment call for cooling.

The air circulating fan operates any time the food compartment or the freezer compartment call for cooling. During the defrost period, the compressor and circulating fan do not operate. The power board opens the electrical circuit to the fan motor and compressor as well as closing the damper door or keeps the damper door closed during the complete defrost cycle .

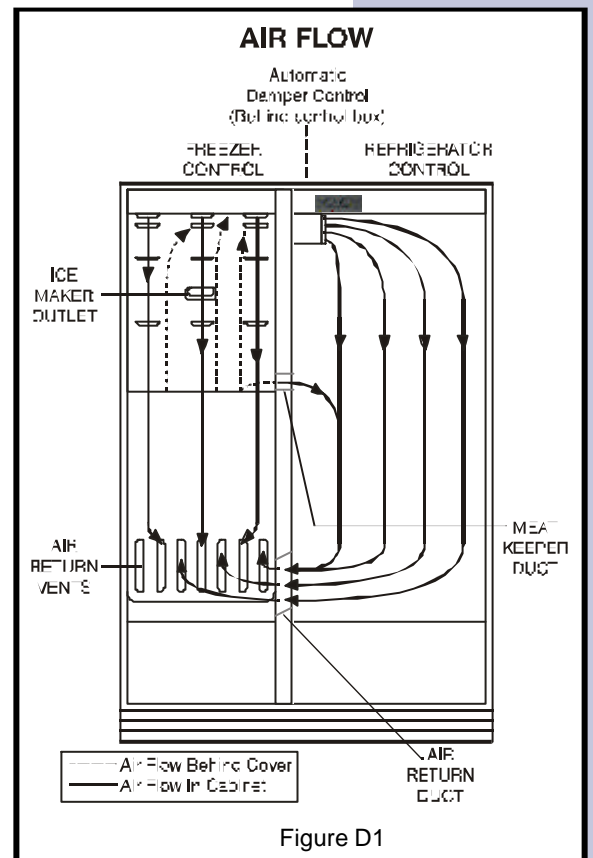

Figure D1

**THIS IS A  
BLANK  
PAGE**

# 48 Section E - Refrigeration System

---

## NOTICE

Instructions given here are furnished as a guide. Persons attempting to use these instructions to make repairs to the sealed refrigeration system should have a working knowledge of refrigeration and previous training on sealed system repair, and an EPA certification for servicing refrigeration systems.

## IMPORTANT NOTICE

Effective July 1, 1992, the United States clean air act governs the disposal of refrigerants such as R-134a. Therefore, when discharging or purging the sealed system, use an epa approved refrigerant recovery system as outlined in the final rule on the protection of stratospheric ozone and refrigerant recycling, which was published in the Federal Register May 14, 1993.

## NOTE

Electrolux Home Products, Inc. does not permit the use of recovered refrigerant in the servicing of our products for in-warranty and out-of-warranty repairs, or for products covered by service contracts. Therefore, only new refrigerant or refrigerant that has been reclaimed back to new specifications by a refrigerant manufacturer is to be used.

## DEFINITIONS

---

### Recovery:

To remove refrigerant in any condition from a system and store it in an external container without necessarily testing or processing it in any way.

### Recycling:

To clean refrigerant for reuse by oil separation and single or multiple passes through devices, such as replaceable core filter-driers, which reduce moisture, acidity and particulate matter. This term usually applies to procedures implemented at the field job site or at a local service shop.

### Reclaim:

To reprocess refrigerant to new product specifications by means which may include distillation. Will require chemical analysis of the refrigerant to determine that appropriate product specifications are met. This term usually implies the use of processes or procedures available only at a reprocessing or manufacturing facility.

---

## SAFETY WARNINGS

### Compressor Testing

Whenever testing a compressor, extreme caution should be used to prevent damaging the terminals. A compressor with a damaged terminal or a grounded winding can expel a terminal from its insulated housing when the compressor is energized. If this happens, a mixture of refrigerant and oil will be released that could be ignited by an external heat source (open flame, heater, etc.). Also, if there is air in the system when this happens, a spark at the compressor shell could ignite the refrigerant and oil mixture

### Charging Sealed Systems

Overcharging a refrigeration system with refrigerant can be dangerous. If the overcharge is sufficient to immerse the major parts of the motor and compressor in liquid refrigerant, a situation has been created which, when followed by a sequence of circumstances can lead to the compressor shell seam separating.

A hydraulic block occurs, preventing the compressor from starting. This condition is known as locked rotor. Electric current continues to flow through the compressor motor windings which become, in effect, electric resistance heaters. The heat produced begins to vaporize the excess refrigerant liquid causing a rapid increase in system pressure. If the compressor protective devices fail, the pressure within the system may rise to extremes far in excess of the design limits. Under these conditions, the weld seam around the compressor shell can separate with explosive force, spewing oil and refrigerant vapor which could ignite.

To eliminate this exceedingly rare but potential hazard, never add refrigerant to a sealed system. If refrigerant is required, evacuate the existing charge and recharge with the correct measured amount of the refrigerant specified for the system.

### Soldering



#### **WARNING**

WEAR APPROVED SAFETY GLASSES WHEN WORKING WITH OR ON ANY PRESSURIZED SYSTEM OR EQUIPMENT. HAVE AN APPROVED DRY TYPE FIRE EXTINGUISHER HANDY WHEN USING ANY TYPE OF GAS OPERATED TORCH.

1. All joints to be soldered must have proper fit. Clearance between tubes to be soldered should be from .001" to .006". It is not practical to actually measure this; however, you do not want a dry fit to be loose. Tubing joints should overlap about the distance of their diameter except for restrictor tubes (capillary tube), which should be inserted 1.25".
2. Clean all joint areas with fine steel wool or preferably an abrasive cloth, such as grit cloth No. 23 or Scotch-Brite.
3. Apply a thin film of liquid flux recommended for silver soldering to surfaces to be joined and to surfaces immediately adjacent to joint.
4. Align tubing so no stress is on joint. Do not move tubing while solder is solidifying or leaks will result.



### CAUTION

During application of heat, use wet cloths to prevent heat from conducting to areas other than the soldered joint. Use a sheet of metal or torch guard pad as a heat deflector to keep flame away from inflammable materials and painted surfaces.

5. Use a torch of adequate capacity so joint can be quickly heated with a minimum of heat travel to other points. Use a good grade of silver solder.
6. Solder connections. If tubing is properly cleaned and fluxed, solder will flow readily. Use only enough solder to make a good bond.
7. Allow joint to cool, then wash exterior with water to remove flux.

## BASIC COMPONENTS

The basic components of a refrigerator are a compressor, condenser, evaporator, heat exchanger (capillary tube and suction line), drier and perimeter hot tube.

### Perimeter Hot Tube

To reduce the possibility of condensation forming on the exterior of the cabinet in high humidity areas, a perimeter hot tube (refrigerant tube) has been installed in the unit. The perimeter tube extends up the left side, across the top of the freezer and down the center mullion and into the filter drier. When the compressor operates, warm refrigerant flows through the primary condenser, then into the perimeter hot tube, warming the cabinet front exterior.

The perimeter hot tube is not replaceable. In the unlikely event of a leak in the hot tube, a kit is available to bypass the hot tube in the sealed system. A electrical heater wire must be installed within the tubing. Refer to the appropriate parts list of the model being serviced for the correct kit part number.

## Refrigerant Cycle

The refrigerant cycle is a continuous cycle that occurs whenever the compressor is in operation. Liquid refrigerant is evaporated in the evaporator by the heat that enters the cabinet through the insulated walls and by the heat from product load and door openings. The refrigerant vapor is then drawn from the evaporator, through the suction line to the compressor. Compression raises the pressure and temperature of the vapor in the compressor and the vapor is then forced through the discharge valve into the discharge line and into the condenser. Air passing over the condenser surface removes heat from the high pressure vapor which then condenses to a liquid. The liquid refrigerant then flows from the condenser to the evaporator through the small diameter liquid line (capillary tube). Before it enters the evaporator, the liquid refrigerant is sub-cooled in the heat exchanger by the low temperature suction vapor in the suction line.

### **LOW OR HIGH SIDE LEAK OR UNDERCHARGE**

A loss of refrigerant can result in any of the following:

1. Excessive or continuous compressor operation.
2. Above normal freezer and /or food compartment temperature.
3. A partially frosted evaporator (depending on amount of refrigerant loss).
4. Low suction pressure (vacuum).
5. Low wattage.

The condenser will be “warm to cool”, depending on the amount of refrigerant lost.

When refrigerant is added, the frost pattern will improve, the suction and discharge pressures will rise, the condenser will become hot and the wattage will increase.

In the case of a low side refrigerant leak resulting in complete loss of refrigerant, the compressor will run but will not refrigerate. Suction pressure will drop below atmospheric pressure and air and moisture will be drawn into the system saturating the filter drier.

If there is reason to believe the system has operated for a considerable length of time with no refrigerant and the leak occurred in the evaporator, excessive amounts of moisture may have entered the system. In such cases the compressor may need to be replaced to prevent repetitive service.

If a slight undercharge of refrigerant is indicated and no leak can be found after a thorough leak test, the charge can be corrected without changing the compressor.

If a high side leak is located and some refrigerant remains in the system it is not necessary to change the compressor.

# 52 Section E - Refrigeration System

## TESTING FOR REFRIGERANT LEAKS

If the system is diagnosed as short of refrigerant and the system has not been recently opened, there is probably a leak in the system. Adding refrigerant without first locating and repairing the leak or replacing the component will not permanently correct the difficulty. **The leak must be found.** Sufficient refrigerant may have escaped to make it impossible to leak test effectively. In such cases, add a ¼" line piercing valve to the compressor process tube. Add sufficient refrigerant vapor to increase the pressure to 40 to 50 lb. per sq. in. Check the low side for leaks. Run the compressor 2 or 3 minutes and check the high side for leaks. Recover refrigerant using an EPA approved recovery system.

### NOTE

The line piercing valve (clamp-on type) should be used for test purposes only. It must be removed from system after it has served its purpose.

## CHECKING FOR INTERNAL (HOT TUBE) LEAKS

Before checking for internal leaks, check all accessible system components and joints for leaks.

If an internal hot tube leak is suspected, it must be confirmed. Use the following procedure:

1. Recover refrigerant by using EPA approved recovery system.
2. After *system refrigerant* is completely recovered, disconnect drier from hot tube. Pinch off and solder end of hot tube closed.
3. Cut line from condenser to hot tube and solder a ¼" charging hose fitting to open end of hot tube or put compression fitting on tube.
4. Connect pressure gauge and access valve to hot tube and pressurize to 250 psig using dry nitrogen or carbon dioxide.



### WARNING

NEVER PRESSURIZE WITH OXYGEN. NEVER OPEN A HIGH PRESSURE TANK UNLESS IT IS EQUIPPED WITH A PRESSURE REGULATOR. NEVER PUT HIGH PRESSURE ON DOME OF COMPRESSOR – IT COULD EXPLODE. MAKE SURE GAUGE, HOSES, AND ALL FITTINGS ARE IN GOOD CONDITION AND DO NOT LEAK.

5. Leave pressure on hot tube for 24 hours. Any drop in pressure is indication of leak.

If dry nitrogen or carbon dioxide is not available, follow steps 1 through 3 on previous page, then steps 4 and 5 below:

4. Connect gauges to charging hose fittings. Pull vacuum on hot tube.
5. Leave vacuum on each side of system for 24 hours. Any loss of vacuum indicates leak.

## COMPRESSOR REPLACEMENT



### CAUTION

NEVER install a new compressor without first checking for possible system contamination.

To check for contamination, obtain oil sample from old compressor.

- If the oil has burned odor, but no color change or residue — follow instructions in section *“Installing A New Compressor and a New 2 Stage Filter-Drier on page 55”*.
- If oil has a burned odor and a sugar or gritty feel as well as showing signs of contamination (dark color) — follow instructions in next section, *To Flush The System*. Remove as much of contamination as possible from system before installing new compressor and a new two stack filter-drier.

### NOTE

It is recommended that system be flushed with dry Nitrogen. However, if refrigerant is used to flush the system you must look at the serial plate to see what type of refrigerant is used in the system. This is the only refrigerant that can be used to flush the system and it must be recovered.



### CAUTION

Use extreme care when using Dry Nitrogen to flush systems. Pressure in nitrogen cylinder could be as high as 2000 psi. Nitrogen cylinder must be equipped with approved pressure regulator and pressure relief valve. Ensure that your hoses have adequate ratings for pressure involved and that all of your equipment is in good condition.

# 54 Section E- Refrigeration System

## CAUTION

The end of the flushing hose on this tank regulator must be equipped with a hand shut-off valve (Robinair No. 40380). Close hand shut-off valve and adjust nitrogen regulator to correct pressure before proceeding with flushing procedure.

### To Use Dry Nitrogen To Flush The System:

1. Remove compressor and filter-drier. Connect process coupling to outlet tube of condenser.
2. Fasten cloth over other end of coil to prevent old oil from spraying over room.
3. Connect hand shut-off valve on flushing hose to process coupling.
4. Slowly open hand shut-off valve and allow nitrogen to flow through condenser until discharge is clear.

## CAUTION

DO NOT exceed 300 PSIG.

5. Disconnect cap tube from evaporator. Flush evaporator in same manner as condenser.

## CAUTION

DO NOT exceed 150 PSIG.

6. Flush cap tube. This is only possible if you have proper service valve adaptor.

## CAUTION

DO NOT exceed 300 PSIG.

7. Reassemble system.

### To Use Refrigerant To Flush The System:

## CAUTION

Refrigerant used for flushing must be recovered into a recovery system. Meter amount of refrigerant used for flushing with your charging cylinder. DO NOT OVERFILL THE SYSTEM.

1. Disconnect the suction and discharge lines from the compressor and remove the filter-drier. Connect process coupling to outlet and inlet tube of condenser.
2. Connect hose to outlet process coupling and charging cylinder. Connect another hose to inlet coupling and recovery system.
3. Open charging cylinder and allow refrigerant to flow through condenser until discharge into bag is clear.
4. Disconnect capillary tube from evaporator. Flush evaporator in same manner as condenser.
5. Flush cap tube. This is only possible if you have proper service valve adaptor.
6. Reassemble system.

## Installing a New Compressor

### NOTE

Entirely new compressors have been developed for use with R-134a and Ester oil refrigeration systems. Both compressor and electric motor have been modified. Old compressors intended for R-12 refrigerant must not be used for new systems charged with R-134a.

Replacement of compressor and installation of filter-drier must be done in a continuous sequence so system is exposed to atmosphere no longer than necessary.

All replacement compressors are shipped with rubber plugs in the suction, discharge and process tubes and contain the correct oil charge and a holding charge of inert gas. Compressors have a low-side process tube attached to the compressor shell. A high-side process tube is attached to the filter-drier.



### WARNING

**DO NOT OPERATE RECIPROCATING COMPRESSOR WHEN CHARGING LIQUID REFRIGERANT INTO SYSTEM THROUGH ITS PROCESS TUBE.**

Replacement compressors for refrigerator may have an oil cooler even if the original compressor did not. If the product is not equipped for an oil cooler, leave the plastic caps in place and install the compressor connecting only to the suction and discharge lines of the new compressor.

# 56 Section E- Refrigeration System

Before installing the replacement compressor remove the discharge plug and check for the pop sound of the inert gas leaving the compressor.

## CAUTION

DO NOT use compressor if you do not hear this sound..

If the compressor checks OK, reinstall the plug. Do not remove any of the plugs again until the compressor is in position and you are ready to braze the lines.

## CAUTION

On R-134a systems, compressor must NOT be left open to atmosphere for more than 10 minutes to prevent moisture contamination of oil.

A new compressor which is cold (e.g. after having been kept in a cold service van) should be left to warm to the surrounding temperature before the plugs on the compressor connections are removed. This will help prevent condensation from forming in the oil and the compressor. Also, avoid opening the system when any of the components or lines are cold.

## NOTE

Release holding charge (release slowly to avoid oil discharge) on new compressor to ensure there is no leak in seam or tubing. Reinstall rubber plug.

1. Disconnect electrical supply to refrigerator.
2. Remove compressor access panel.
3. Recover refrigerant by using EPA approved recovery system.
4. Remove leads from compressor motor terminals.
5. Remove mounting clips and washers.
6. Remove inoperable compressor and transfer mounting parts to new compressor.
7. Drain oil from old compressor and mark with approved tag that oil has been removed.
8. Remove suction line from old compressor and install on new compressor.
9. Install new compressor in exact same manner as original compressor.

10. Reform both suction and discharge lines to align with new compressor. If they are too short, use additional lengths of tubing. Joints should overlap 0.5" to provide sufficient area for good solder joint. Clean and mark area where tubing should be cut. Cut tubing with tubing cutter. Work as quickly as possible to avoid letting moisture and air into system.

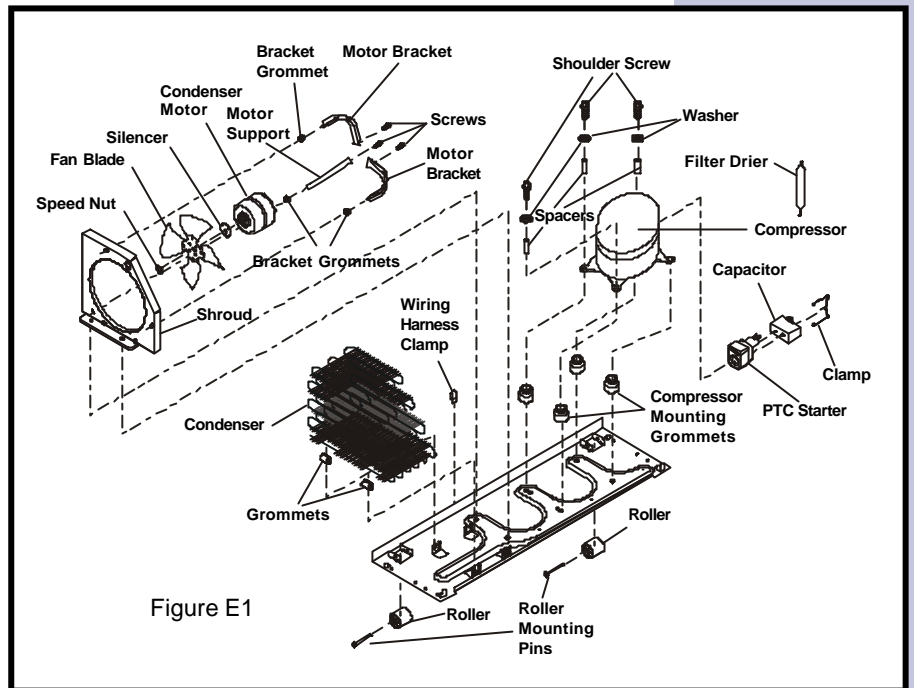

## NOTE

If low-side process tube is too short, silver solder four inch piece of tubing onto process tube before installing compressor.

11. Solder all connections according to soldering procedure outlined on page 49.
12. Remove original filter-drier.



## CAUTION

DO NOT unbrazed old filter-drier from system. This will vaporize and drive moisture from desiccant back into system. The old filter-drier should be cut out of system.

13. Install new filter-drier at condenser outlet.

## NOTE

If system is and/or old compressor oil is badly contaminated, use the new 2 stage drier-filter, part # 5303918288. Refer to Service Bulletin Volume 23, # 3, page 13.

14. Evacuate and charge system using recommended procedure described under Evacuating and Recharging.
15. Reconnect compressor terminal leads in accordance with refrigerator wiring diagram.
16. Reassemble unit.

# 58 Section E- Refrigeration System

## EVAPORATOR REPLACEMENT

### CAUTION

Always use the TORCH GUARD heat shield part number 5304418872, behind evaporator before attempting to solder. The excessive heat from soldering will warp the plastic liner.

The evaporator is located in the lower section of the freezer and is secured to the drain pan by a bracket at the top. Styrofoam blocks are located on each side, directly across from each other to ensure proper air flow through the evaporator.

The heat exchanger on this style of refrigerator is in the insulation between the liner and the cabinet back. You will not be able to remove the heat exchanger with the evaporator. Because of this, all line welds will be made inside the freezer. The evaporator kit contains a heat shield to protect the liner from damage when brazing.

#### Evaporator Kit Contains:

1 Evaporator	1 Heat Shield
1 Drier-Filter	1 Instruction Sheet

1. Disconnect refrigerator from electrical supply.
2. Remove all freezer section shelves and baskets.
3. Remove bottom evaporator cover.
4. Disconnect wiring harness at liner plug. Remove defrost limiter and disconnect defrost heater. (See Figure 1)

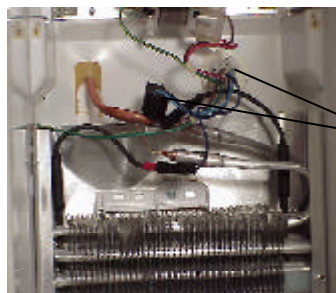

Disconnect plug and remove limit switch

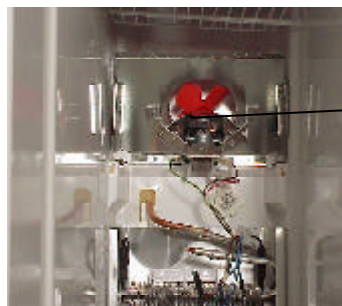

Slide fan and bracket out of liner.

FIGURE 1

5. Cut suction line in front of weld at evaporator. Using a file, score and break the cap tube just in front of the weld. (See Figure 2.)
6. Remove drain trough and evaporator from inside the freezer.
7. Clean end of suction line and cap tube. Straighten line and slightly bend toward front of cabinet to aid in installing shield.
8. Cut a small "X" in heat shield, then slide cap tube and suction line through hole. Pack heat shield in back corner of liner. (See Figure 3.)

## NOTE

You may need to use a small pair of vise-grips on the suction line to help hold the heat shield in place.

9. Remove rivet in retainer at top of old evaporator. Slide evaporator out top of drain trough.
10. Transfer defrost heater and foam blocks from old evaporator to new evaporator, then slide evaporator into top of drain trough.
11. Slide evaporator and drain trough in place and push drain trough over heat shield. This will help hold shield in place. (See Figure 3.)
12. Place cap tube in new evaporator and weld in place.
13. Place suction line in new evaporator and weld in place.
14. With a sharp knife, cut along a seam on the heat shield from center hole to edge of shield. Slide shield from between liner, drain trough and suction line assembly.

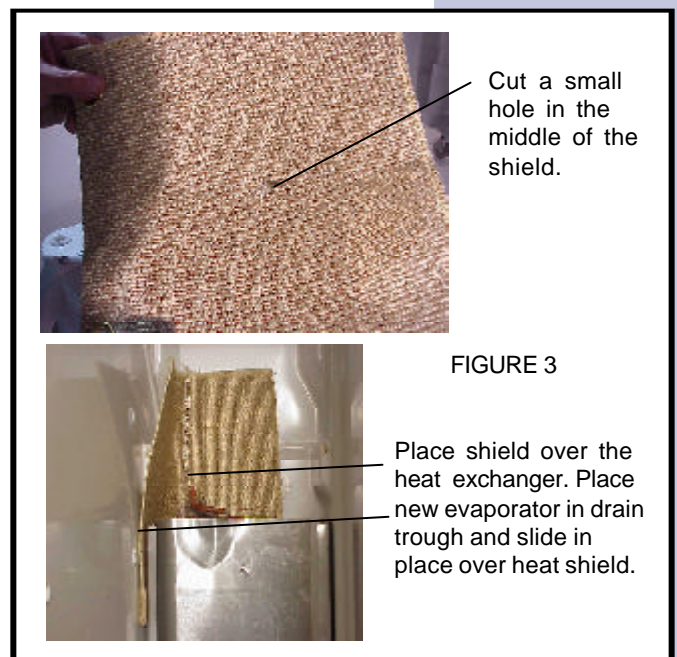
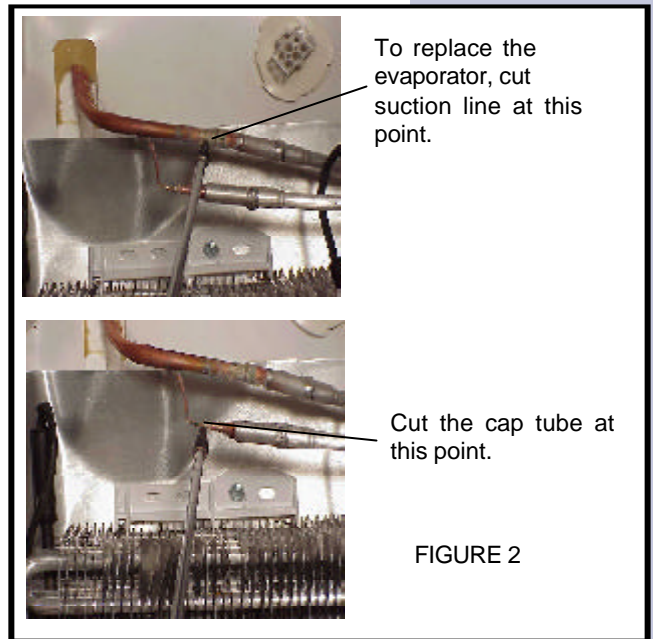

# 60 Section E- Refrigeration System

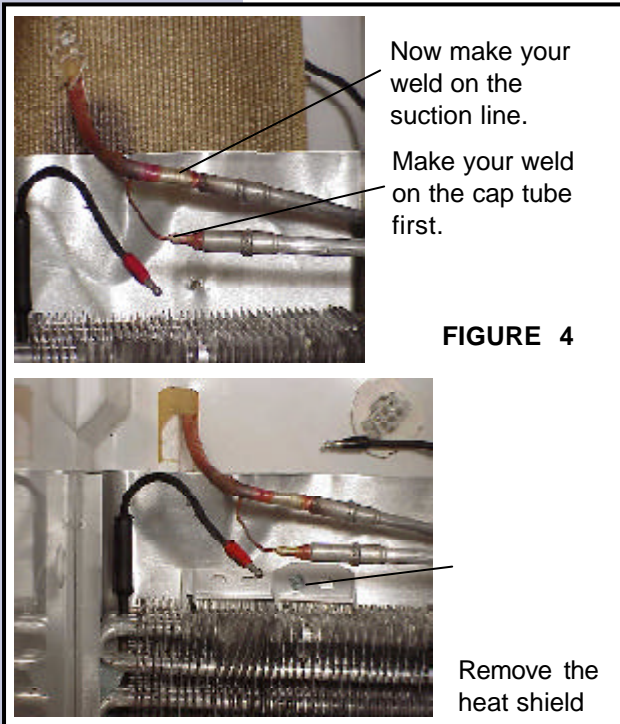

15. Push evaporator back in place and reinstall plastic clamp at top. (See Figure 4.) There is no need to replace the rivot.
16. Slide fan and bracket assembly in place and connect defrost heater. Mount limit switch on evaporator. Plug wiring harness into connector on liner.
17. Replace Drier-Filter. Pump down and recharge system.

## NOTE

If system is and/or old compressor oil is badly contaminated, use the new 2 stage drier-filter, part # 5303918288. Refer to Service Bulletin Volume 23, # 3, page 13.

18. Allow product to run and make sure refrigerant is circulating. Reinstall evaporator cover and machine compartment cover.

## HEAT EXCHANGER REPLACEMENT

### CAUTION

Always use the TORCH GUARD heat shield behind evaporator before attempting to solder. The excessive heat from soldering will warp the plastic liner.

The original heat exchanger (Suction Line & Cap Tube Assembly) in this product is enclosed in the insulation between the liner and the cabinet back. Because of this, the original part cannot be removed. There is a service kit to bypass the internal heat exchanger. It will be necessary to run a new heat exchanger down the back of the product and bypass the internal heat exchanger.

#### Heat Exchanger Kit Contents:

1 Heat Exchanger	6 Screws
1 Drier-Filter	1 Cover
1 Armor Flex	1 Package Permagum
2 Tape	1 Instruction Sheet

## To replace the heat exchanger:

1. Recover refrigerant from sealed system.
2. Disconnect wiring harness at liner plug.
3. Remove defrost limiter and disconnect defrost heater.
4. Remove fan motor and wiring.
5. Cut heat exchanger off flush with liner. (See Figure 1.)
6. Remove evaporator and drain trough.

### NOTE

You do not need to remove rivet or defrost heater.

7. Using a 1/4" drill bit, drill hole through cabinet from inside at location shown in Figure 2.
8. Using a 1/2" drill bit, open hole drilled in Step 7 to 1/2" from back of product. (See Figure 2.)
9. Remove stubs of old heat exchanger from evaporator and install new heat exchanger into evaporator.
10. Push heat exchanger through hole in cabinet (See figures 3 & 5.) and set evaporator back in place.
11. Slide Armor-Flex over heat exchanger until cover is against hole at back of cabinet. The excess cap tube can be wound around the suction line.
12. Seal the hole on the inside and outside using Permagem. (See Figs 3 & 5)
13. The one piece cover can now be installed over heat exchanger. Place open end of cover with top of compressor compartment opening. Attach cover to back of cabinet using screws provided. There is no need to predrill holes as the screws are self cutting. (See Figure 4.)

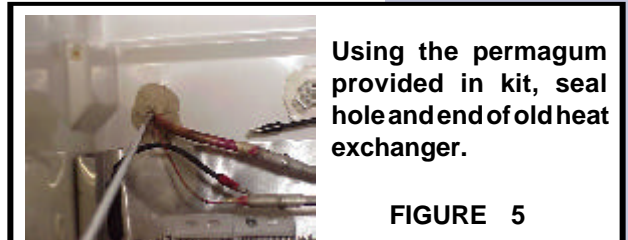
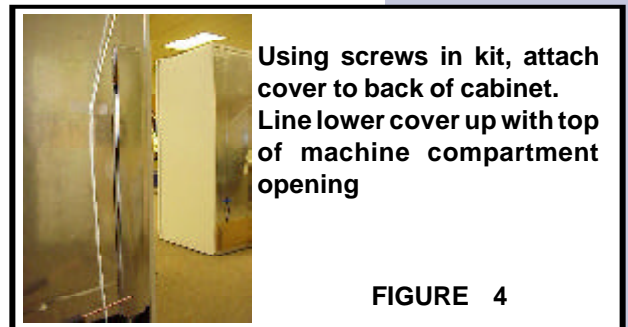
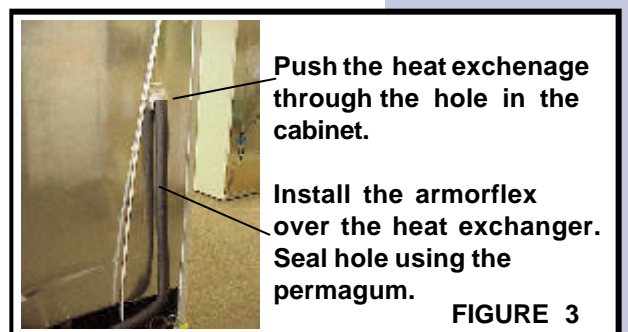
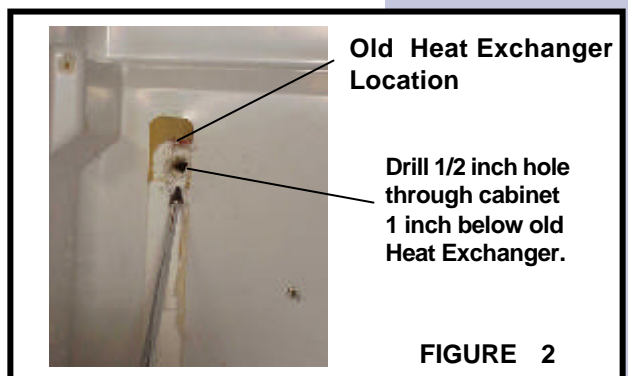
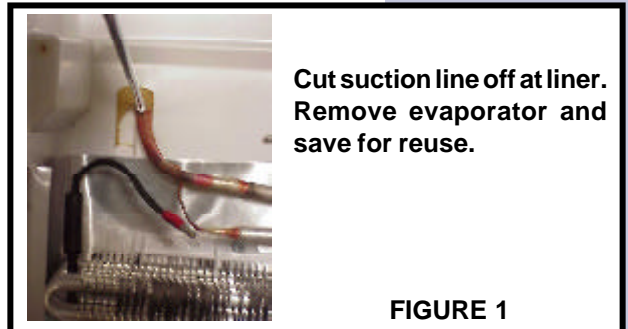

# 62 Section E- Refrigeration System



Using the permagum provided in kit, seal hole and end of old heat exchanger.

FIGURE 6

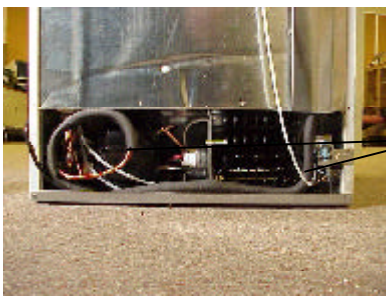

Bend tubing as shown to fit inside machine compartment.

FIGURE 7

14. Seal hole and end of old heat exchanger with Permagem. (See Figure 6.)
15. Replacr Drier-Filter.
16. Evacuate and recharge system.
17. Bend remaining tubing to fit into machine compartment opening, being careful not to set up any excess noise from line vibration. (See Figure 7.)
18. Run product to make sure refrigerant is circulating.
19. Reinstall evaporator and machine compartment cover.

## PERIMETER HOT TUBE REPAIR KIT

Effective July 1, 1992, Section 608 of the **Clean Air Act** prohibits Individuals from knowingly venting ozone depleting compounds used as refrigerants into the atmosphere while maintaining, servicing, repairing, or disposing of refrigerant equipment.

A hot tube repair kit is used to bypass a leaking Perimeter Hot Tube (Yoder-Loop). The Perimeter Hot Tube must be bypassed in the sealed refrigeration system and a low wattage heater wire installed inside the tube. This heater will prevent condensation from forming on the exterior front edge of the cabinet.

### Hot Tube Heater Kit Contents:

1 Copper Bypass Tube	1 Plastic Sleeve
1 Drier-Filter	1 Heater Wire
3 Clamps	1 Harness Adapter
3 Screws	2 Wire Connectors

### Bypassing Perimeter Hot Tube - Step 1

1. Disconnect service cord from power supply.
2. Recover refrigerant from system.
3. Remove filter-drier.
4. Using tubing cutter, cut and de-burr tubing from perimeter hot tube at points shown in figure below.

# Section E- Refrigeration System 63

5. Install copper bypass tube and replacement filter-dryer as shown in figure below. Use 45% silver solder for all connections.
6. Drill or pierce three holes in cabinet to hold clamps. Secure by-pass tube just below cabinet edge with three clamps and screws provided.

## NOTE

When clamped in place the by-pass tube should NOT touch any plastic lines, such as water lines for ice makers and/or filters as well as drain lines.

7. Evacuate and recharge refrigeration system. Refer to serial plate for correct charge.

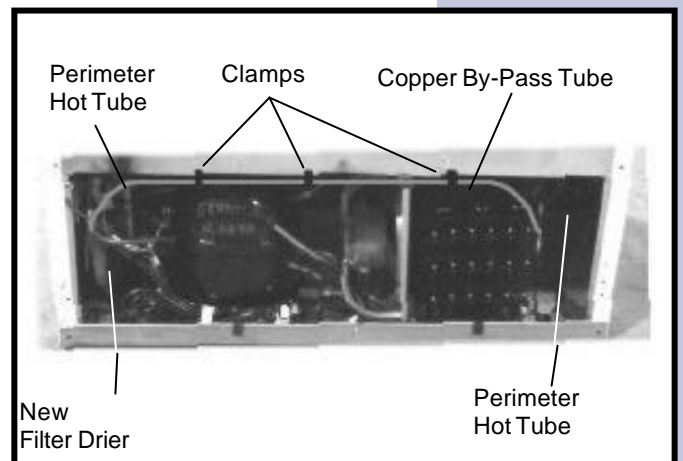
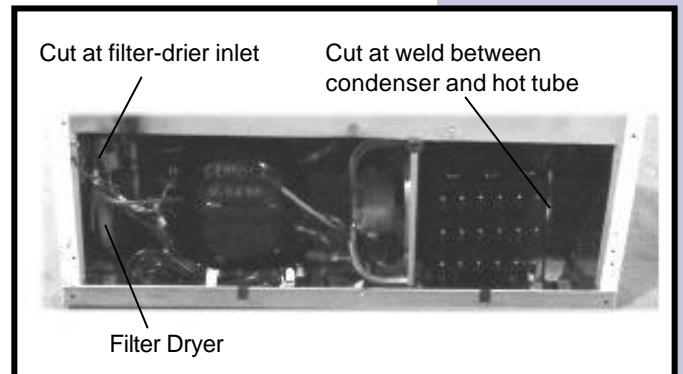

## Installing The Heater Wire - Step 2

1. Attach Vacuum Pump and hose to one end of Perimeter Hot Tube with an Adapter and Plastic Sleeve. See Figure 1 on next page.
2. Make a knot in the end of the fiberglass braid that is extended past the end of the heater wire just a little smaller than the inside diameter of the hot tube.
3. Insert knot on end of braid into open end of Perimeter Hot Tube.
4. With braid inserted, start Vacuum Pump and place your thumb over end of tube. When good vacuum is obtained, release your thumb and begin to feed braid into Hot tube. Continue this process until string reaches Plastic Sleeve.

## NOTE

Take the time to remove all the bends from the heater (caused from being rolled up) by pulling the heater and braid through a shop rag with a small amount of silicone on the rag and laying it in a roll at the open end of the Hot Tube. It will make heater installation go faster. Using a good two stage, 5 CFM Vacuum Pump will also make heater installation go faster.

# 64 Section E- Refrigeration System

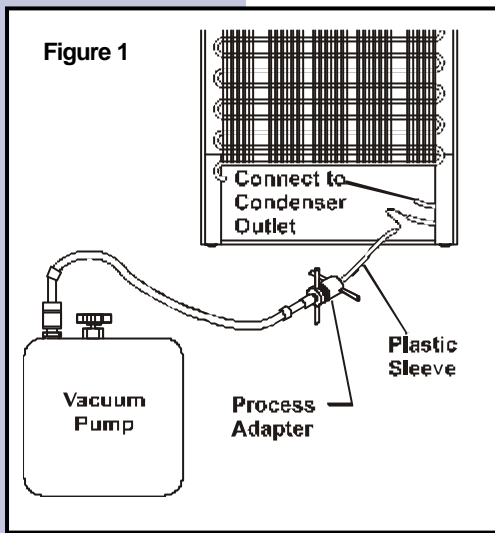

5. Disconnect Plastic Sleeve.
6. Pull braid out while pushing equal amount of braided heater into tube at other end until heater wire inside braid appears.

## Installing The Heater Wire - Step 3

1. Remove wires (with terminals) from compressor starter/overload. On some models you will need to depress locking tabs located in relay housing (See Figure 2.)
2. Install harness adapter into refrigerator circuit as shown in Figure 3.
3. Cut off braid at start of heater. Strip insulation back about 5/16 inch. Be careful not to damage heater resistance wire. Splice heater wire ends to loose leads of adapter harness with furnished wire connectors.
4. Dress wires away from Condenser Fan Blade and any sharp edges.
5. Secure wires with electrical tape as necessary.
6. Reinstall Back Panel for proper air flow over condenser and compressor.

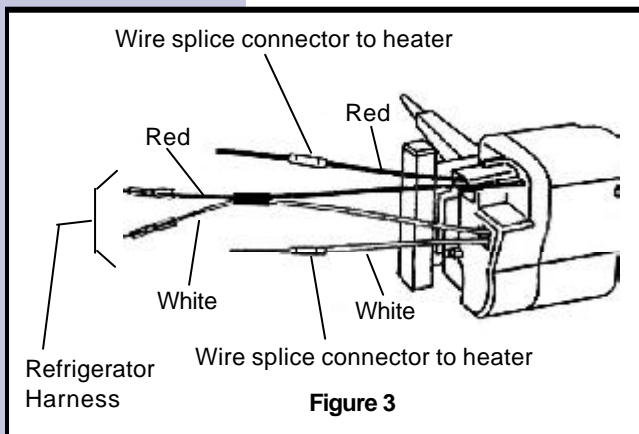
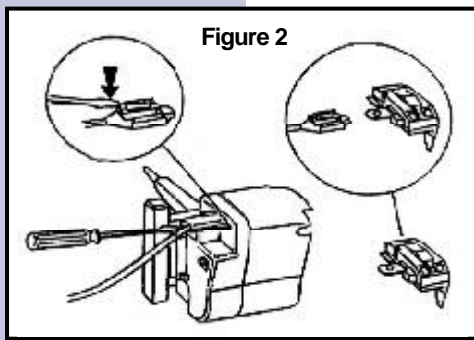

## CONDENSER REPLACEMENT

1. Disconnect electrical supply to refrigerator.
2. Remove compressor access panel.
3. Recover refrigerant by using EPA approved recovery system.
4. Remove condenser fan mounting screws.
5. Unplug fan motor harness located in back of fan motor.
6. Remove fan motor, fan blade, and water valve assembly.
7. After refrigerant is completely recovered, disconnect inlet and discharge lines from condenser.
8. Remove white condenser retainer clip from fan bracket and condenser.
9. Lift front of condenser and the two rubber grommets out of retainer in base plate.
10. Remove old condenser out the back of cabinet.
11. Install replacement condenser.
12. Remove original filter-drier.



### CAUTION

DO NOT unbrazed the old filter-drier from the system. This will vaporize and drive moisture from the desiccant back into the system. The old filter-drier should be cut out of the system.

Use a Heat Shield to protect plastic tubing when brazing connections.

13. Install new filter-drier at end of hot tube.
14. Evacuate and charge the system using recommended procedure described under Evacuating and Recharging on pages 27-28.
15. Reassemble unit.

# 6 6 Section E- Refrigeration System

## FILTER-DRIER INSTALLATION

Any time the sealed system is opened and the refrigerant charge is removed, the liquid line filter-drier must be replaced and the system thoroughly evacuated before recharging.



### CAUTION

DO NOT unbrazed the old filter-drier from the system. This will vaporize and drive moisture from the desiccant back into the system. The old filter-drier should be cut out of the system.

### NOTE

If system is and/or old compressor oil is badly contaminated, use the new 2 stage drier-filter, part # 5303918288. Refer to Service Bulletin Volume 23, # 3, page 13.



### CAUTION

Use only a 15 gram XH9 liquid line filter-drier (part number 5303305677) when servicing refrigerator and freezer systems. This filter-drier is compatible with either R-12 or R-134a refrigerant.

1. Disconnect unit from source of power.
2. Recover refrigerant by using an EPA approved recovery system.
3. Using a 3 cornered file, score a groove around capillary tube as close to old filter-drier as possible. Break capillary tube along score mark from filter-drier.
4. Cut hot tube at filter-drier. Discard filter-drier.
5. Thoroughly clean end of hot tube and capillary tube.
6. Place inlet connection of filter-drier over condenser tube approximately 1/4" and solder.
7. Insert capillary tube input end into filter-drier outlet. Do not allow tube to bottom against screen. Solder carefully so that solder does not plug capillary tube.
8. Install process tube adaptor to filter-drier.
9. Evacuate and charge system using the recommended procedure described under Evacuating and Recharging on page 67. **When using the two stage drier-filter, add an additional 1/4 ounce of refrigerant to what's required on the serial plate charge.**
10. Reassemble unit.

## EVACUATING AND RECHARGING

---

### CAUTION

Check the serial plate for the correct refrigerant type. It is extremely important to verify the type of refrigerant in the system before starting any sealed system repairs.

### CAUTION

With the possible exception of the vacuum pump, all service equipment that comes in contact with R-134a during evacuation and recharging must be dedicated. Accordingly, R-134a will require a dedicated charging cylinder, manifold gauge set, process tube adaptors, and hoses. Any residual mineral oil on other tools (tubing cutter, etc.) must be thoroughly cleaned off before using on R-134a/Ester oil systems. It will be necessary to check with the manufacturer of your vacuum pump for refrigerant and oil compatibility issues.

### CAUTION

If you use a vacuum pump with mineral oil to evacuate an R-134a system, it is **ABSOLUTELY ESSENTIAL** to have a shut-off valve between the pump and your manifold gauge set as shown on page 32, Figure E2. The hand valve must be closed during all times when the vacuum pump is not operating. This will prevent the migration of mineral oil vapor into the R134a/Ester oil system. If the vacuum pump should stop during evacuation for any reason, the hand pump shut-off valve must be closed immediately.

### CAUTION

Insure that your refrigeration hoses are specified for use with R-134a refrigerant. Research has shown that compounds in standard refrigeration hoses may enter sealed systems and ultimately restrict the cap tube in an R-134a system.

### Equipment Needed for Evacuation & Recharging:

- Heated charging cylinder
- Standard 3-port manifold gauge set:
  - 4 charging hoses
  - Tee fitting with valve core stem removed (Robinair No. 40396)
  - Hand shut-off valve (Robinair No.40380)
- Two stage vacuum pump
- Process tube adapter kit (Robinair No. 12458)
- Tubing cutter
- Pinch-off tool capable of making leak proof seal
- Complete brazing torch set
- Small 3-corner file
- Grit cloth or Scotch-Brite
- 45% silver solder and flux

### Installing Evacuation and Recharging Equipment

1. Disconnect refrigerator from electrical supply.
2. If compressor was replaced, install correct sized process tube adaptor on process tube. If compressor was not replaced, cut process tube with tubing cutter leaving as much tube as possible and install correct size process tube adaptor.
3. Install correct sized process tube adaptor on high-side process tube.
4. Attach refrigeration service gauge manifold to system in following order:
  - Low-side (compound gauge) hose to suction side process tube adaptor.
  - High-side (pressure gauge) hose to high-side process tube adaptor.
  - Center port manifold hose before hand shut-off valve to charging cylinder.
  - Center port manifold hose after hand shut-off valve to vacuum pump.

### Evacuating System



#### **WARNING**

R-134A SYSTEMS ARE PARTICULARLY SUSCEPTIBLE TO MOISTURE CONTAMINATION WHICH CAN ONLY BE PREVENTED BY EVACUATING THE SYSTEM FOR A MINIMUM OF 30 MINUTES TO ATTAIN A MINIMUM 29.9 INCH (500 MICRON OR LOWER) VACUUM.

---

To achieve the required levels of evacuation, a properly maintained two stage vacuum pump in good condition is required. It is absolutely essential to maintain your vacuum pump according to the manufacturer's instructions including required oil changes at the recommended intervals. Vacuum pump oil should always be changed after evacuating a contaminated system.

Vacuum pump performance should be checked periodically with a micron gauge.

1. Make certain that charging cylinder valve, hand shut-off valve, and manifold gauge valves are closed.
2. Start vacuum pump.
3. Open hand shut-off valve and slowly open both manifold valves, turning counterclockwise, for two full rotations.



## CAUTION

If high vacuum equipment is used, just crack both manifold valves for a few minutes and then open slowly for the two full turns counterclockwise. This will prevent the compressor oil from foaming and being drawn into the vacuum pump.

4. Operate the vacuum pump for a minimum of 30 minutes to a minimum of 29.9" (500 micron) vacuum.
5. Close hand shut-off valve to vacuum pump. Watch compound gauge for several minutes. If reading rises, there is a leak in the system, go to step 6. If no leak is indicated, stop vacuum pump. System is now ready for charging.
6. If a leak is indicated, stop vacuum pump and introduce a small charge of refrigerant into system by cracking valve on bottom of charging cylinder until system is pressurized to 40 or 50 lbs psig.
7. Leak test low-side. Close compound gauge. Run compressor for a few minutes and leak test high-side. When leak is found, recapture refrigerant using EPA approved recovery system Repair and go back to step 1.

## Charging The System



## CAUTION

Check the serial plate for the correct refrigerant type. It is extremely important to verify the type of refrigerant in the system before starting any sealed system repairs.



## CAUTION

After charging the system with liquid be certain to wait at least 5 minutes before starting the compressor to give the refrigerant a chance to disperse throughout the system. Otherwise the compressor could be damaged by attempting to pump excessive quantities of liquid.

### Preparing The Charging Cylinder:

1. Make certain that hand shut-off valve to vacuum pump is closed.
2. Close high-side manifold gauge valve.
3. Set charging cylinder scale to pressure indicated on cylinder pressure gauge.
4. Observe refrigerant level in sight glass. Subtract amount to be charged into system and note shut off point.
5. Open charging cylinder valve slowly and allow proper charge to enter system.
6. As soon as refrigerant in sight glass has gone down to predetermined level, close charging cylinder valve.



### WARNING

**DISCONNECT THE CHARGING CYLINDER HEATER AT THIS TIME TO PREVENT THE CYLINDER PRESSURE FROM EXCEEDING ITS MAXIMUM LIMITS.**

7. Allow system to sit for five minutes.
8. Turn on refrigerator compressor. Run compressor for a few minutes and monitor system pressures.
9. When satisfied that the unit is operating correctly, clamp the high-side process tube with the pinchoff tool while the unit is still running.
10. Slowly open the high-side manifold gauge valve to allow the compressor to remove any refrigerant trapped in the high-side hose and the process fitting.
11. Close both of the manifold gauge valves. If the high-side gauge reading rises, the pinch-off must be corrected before proceeding.
12. Remove the high-side process tube adaptor and solder the process tube closed.
13. Clamp the low-side process tube with the pinch-off tool while the unit is running. Remove the low-side process tube adaptor and solder the process tube closed.
14. Check the process tubes for refrigerant leaks.

### Final Leak Test

1. With the refrigerator turned OFF leak test all low-side system components.
  2. Turn the unit ON and run until the condenser is warm. Leak test the high-side system components.
-

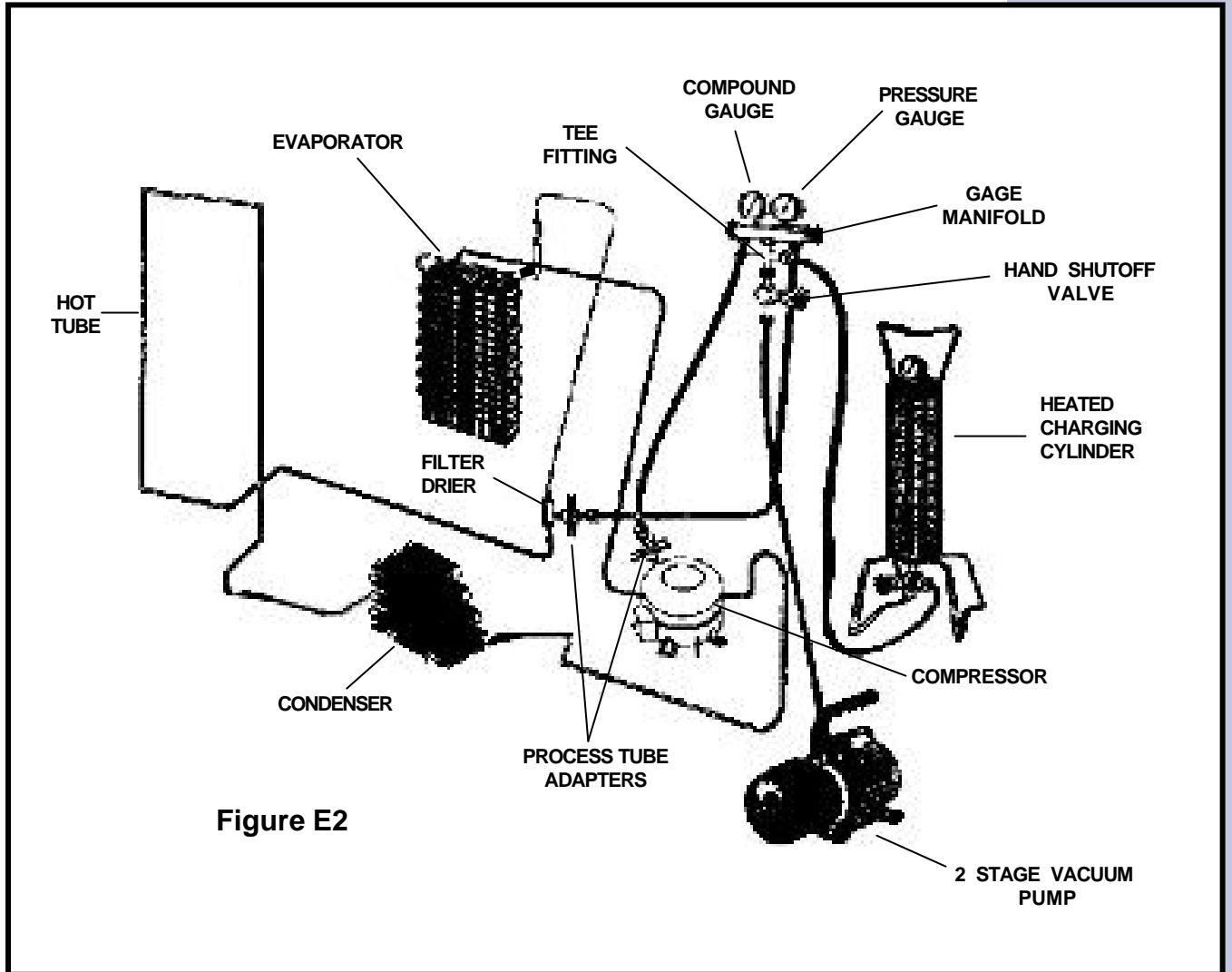

Figure E2

## R-134A SERVICE INFORMATION

### NOTICE

Instructions given here are furnished as a guide. Persons attempting to use these instructions to make repairs to the sealed refrigeration system should have a working knowledge of refrigeration and previous training on sealed system repair.

### Verify Refrigerant Type In The System

#### CAUTION

R-134a and R-12 are completely incompatible. Before starting any sealed system repair, it is extremely important to check serial plate of product to verify the type of refrigerant in the system.

### Dedicated Equipment

R-134a must not be mixed with other types of refrigerants. R-134a must be recovered in dedicated and properly identified recovery bags and tanks.

It will be necessary to check with the manufacturer of your recovery equipment to determine R-134a compatibility. Some recovery equipment manufacturers have changeover instructions for switching between refrigerant types. Protect yourself and your equipment by following all manufacturer guidelines.

Also, ensure that your refrigeration hoses are specified for use with R-134a refrigerant. Research has shown that compounds in standard refrigeration hoses may enter sealed systems and ultimately restrict the cap tube in an R-134a system.

### R-134a Refrigeration Systems

The sealed refrigeration system will consist of the same basic components being utilized in the R-12 systems.

There is a 10% to 15% discharge pressure increase using R-134a, with a 5% to 10% decrease in suction pressure when compared to the same product with an R-12 system operating at 90°F (32°C) ambient temperature conditions. Lower suction pressures result from the lower density of R-134a refrigerant which effects refrigerant flow rate. R-134a systems commonly operate in a 1"-2" vacuum on the suction side.

Products using R-134a refrigerant will generally have a longer capillary tube to maintain a similar flow rate and some models will have a larger condenser to reduce the discharge pressures and lower start-up sound transmission.

## Miscibility Of R-134a And Ester Oil

A special synthetic oil known as Ester oil is used as a lubricant in refrigeration systems operating on R-134a. Ester oils are produced from alcohols and fatty acid and are available in several different variants. Ester oils have a pleasant aroma reminiscent of fruit.

Ester oils generally include various types of additives for improving certain properties such as viscosity, temperature sensitivity, etc. These additives are often aggressive, and skin contact with Ester oils should therefore be avoided.

One of the most important requirements made on a refrigerant system is that the oil mix with the refrigerant. Since mineral oil and ordinary synthetic oil DO NOT mix with R-134a, Ester oil is used for lubrication. Ester oil dissolves in R-134a.

Ester oil is broken down by chlorine and cannot be used with R-12 (R-12 contains chlorine) or any other compound containing chlorine. Therefore, R-134a refrigeration systems have virtually no tolerance for chlorine molecules from CFC refrigerants (R-134a is an HFC and contains no chlorine).



### CAUTION

During R-134a service, it is extremely important to avoid using equipment that may contain residual amounts of mineral oil, CFC's or HCFC's which could enter and contaminate the sealed system.

For example, hoses that were used for a refrigeration system operating on R-12 may contain small quantities of mineral oil which can block the capillary tube in a system operating on R-134a. As little as one milligram may be sufficient to cause a blockage. In addition, sealed system components that have been used with CFC systems must not be used with R-134a systems. These components may contain residual amounts of refrigerant and oil which could damage an R-134a system.

At the earliest stage of development work on R-134a, tests were carried out on a different type of synthetic oil known as Poly-Alkaline Glycol (PAG). This oil is also used in certain air conditioning systems for cars. PAG and Ester oil DO NOT mix with one another. Service equipment used for R-134a / Ester oil must not come into contact with PAG.

# 74 Section E

## Water In The Refrigeration System

Even in very small quantities, water in any refrigeration system can cause the following problems:

- Ice plugs in capillary tubes.
- Copper plating in compressor.
- Reactions with organic materials in systems.
- Corrosion of metals.

R-134a and Ester oil will aggravate the problem of water in the refrigeration system. Ester oil may react with water vapor and is hygroscopic (it will absorb water if it comes in contact with humid air). Water is also more soluble in R-134a than R-12.

To minimize the water content whenever service work is performed, the refrigeration system should always be thoroughly evacuated through process tube adaptors on both the high and low sides of the system. Evacuation must be for a minimum of 30 minutes to at least a 29.9 inch (500 micron) vacuum.

VACUUM CHART		
Vacuum Inches Hg.	Microns	Boiling Point of Water °F
28.940	25000	77.9
29.530	10000	52.0
29.832	4600	32.0
29.882	1000	1.0
29.901	500	-11.2
29.915	150	-32.8
29.917	100	-38.2
29.919	50	-49.0

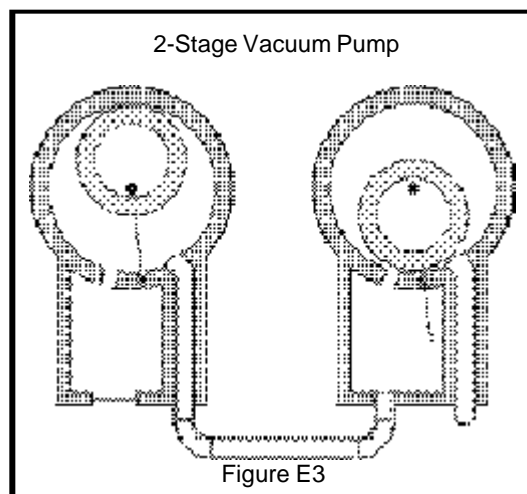

To achieve the required 29.9 inch (500 micron) vacuum, a properly maintained two-stage vacuum pump in good condition is required. A two stage pump can reach a deeper vacuum than a single stage because the exhaust from the first pumping stage is discharged into the second pumping stage. This means the second stage begins pumping at a lower pressure so a lower ultimate vacuum can be achieved (See 2-Stage Vacuum Pump, Figure E3).

## Vacuum Pump Maintenance

It is absolutely essential to maintain your vacuum pump according to the manufacturer's instructions including required oil changes at the recommended intervals. Vacuum pump oil should always be changed after evacuating a contaminated system. Vacuum pump performance should be checked periodically with a micron gauge.

Vacuum pump suppliers may or may not recommend changing the vacuum pump oil to the same type that's in the system being evacuated. Some manufacturers may recommend a vacuum pump that's dedicated to R-134a systems.

Robinair has stated that their current and discontinued vacuum pump models, using mineral oil currently specified for use in their vacuum pumps, can be used to evacuate R-134a/Ester oil systems. Robinair also states that it is acceptable to alternate between evacuating R-12/mineral oil and R-134a/Ester oil systems without adversely affecting the vacuum pump's performance.

For other brands of vacuum pumps, check with the manufacturer for restrictions and guidelines when using with R-134a.

### CAUTION

If you use a vacuum pump with mineral oil to evacuate an R-134a system, it is **ABSOLUTELY ESSENTIAL** to have a shut-off valve between pump and your manifold gauge set as shown in Figure E4. The hand valve must be closed during all times when vacuum pump is not operating. This will prevent migration of mineral oil vapor into R134a/Ester oil system. If vacuum pump should stop during evacuation for any reason, the hand pump shut-off valve must be closed immediately.

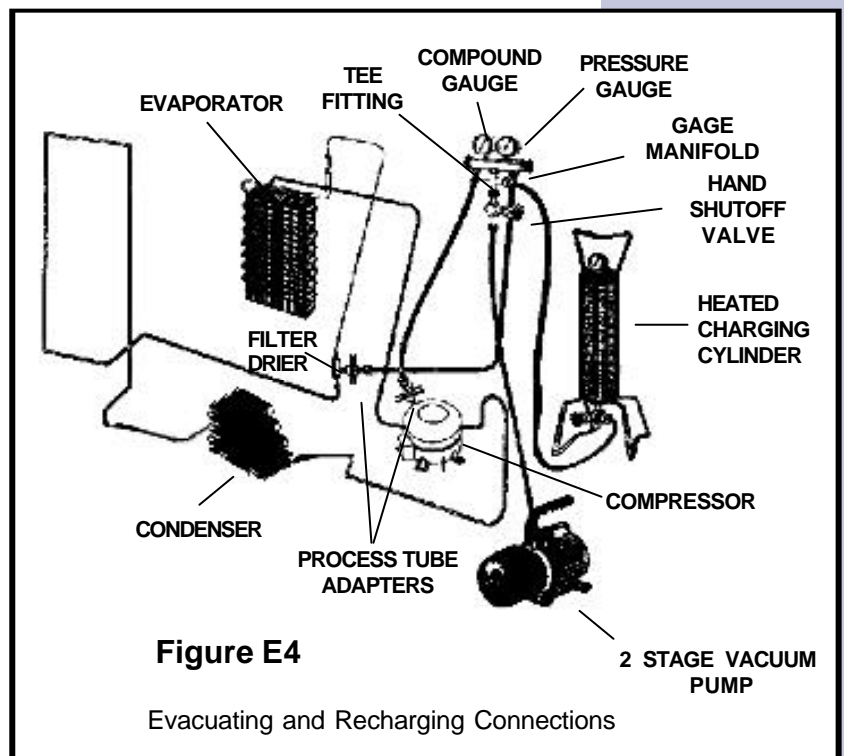

# 76 Section E

## Refrigerant Leaks

A system with R-134a and Ester oil will become saturated with moisture much faster than a system with R-12 and mineral oil. The compressor in an R-134a system will have to be replaced if the product has had a low side leak.

R-134a refrigerant molecules are smaller than R-12 molecules. This means that R-134a will pass more minor leaks and the rate of flow will be greater than for R-12. Therefore, it is now more important than ever to follow good brazing practices. Use a good grade of silver solder. 45% silver solder is recommended.

## Leak Detection

R-134a system leaks can be pinpointed by means of an electronic leak detector or by bubble solution.

Electronic leak detectors for R-134a service are currently available from several manufacturers. The least expensive models are non-selective detectors that will detect any type of emission or vapor present, regardless of its chemical composition. Some non-selective detectors designed for use with R-12 may have a much lower sensitivity when used with R-134a. However, newly designed detectors with good R-134a sensitivity are now available. Be sure to consult with the manufacturer before selecting or using a non-selective detector with R-134a.

Halogen-specific detectors use a specialized sensor that allows detection of compounds containing chlorine, fluorine, bromine, and iodine without being activated by other species. The major advantage of this type of detector is a reduction in the number of "nuisance alarms". Halogen-specific detectors are generally more expensive than non-selective detectors but feature higher sensitivity.

## R-134a properties

The properties of R-134a are very similar to those of R12. The principal data for the two refrigerants are shown in the chart below.

	REFRIGERANTS	
	R-12	R-134a
<b>NAME</b>	Dichlorodifluoromethane	1,1,1,2--Tetrafluoromethane
<b>Formula</b>	CCl <sub>2</sub> F <sub>2</sub>	CH <sub>2</sub> F-CF <sub>3</sub>
<b>Molecular Weight (g/mol)</b>	120.93	102.3
<b>Ozone Depletion Potential (ODP)</b>	1	0
<b>Global Warming Potential (GWP)</b>	3.1	0.3
<b>Boiling Point °F</b>	-21.6	-15.7
<b>Vapor Pressure (77°F)</b>	80 psig	82 psig
<b>Flammability</b>	None	None
<b>Solubility of Water in Refrigerant (wt% @ 77°F)</b>	0.009	0.11

## HFC-134a, CFC-12 PRESSURE TEMPERATURE CHART

°F	°C	HFC-134a	CFC-12		°F	°C	HFC-134a	CFC-12
-60	-51.1	21.8*	19.0*		55	12.8	51.1	52.0
-55	-48.3	20.4*	17.3*		60	15.6	57.3	57.7
-50	-45.6	18.7*	15.4*		65	18.3	63.9	63.8
-45	-42.8	16.9*	13.3*		70	21.1	70.9	70.2
-40	-40.0	14.8*	11.0*		75	23.9	78.4	77.0
-35	-37.2	12.5*	8.4*		80	26.7	86.4	84.2
-30	-34.4	9.8*	5.5*		85	29.4	94.9	91.8
-25	-31.7	6.9*	2.3*		90	32.2	103.9	99.8
-20	-28.9	3.7*	0.6		95	35.0	113.5	108.3
-15	-26.1	0.0	2.4		100	37.8	123.6	117.2
-10	-23.3	1.9	4.5		105	40.6	134.3	126.6
-5	-20.6	4.1	6.7		110	43.3	145.6	136.4
0	-17.8	6.5	9.2		115	46.1	157.6	146.8
5	-15.0	9.1	11.8		120	48.9	170.3	157.7
10	-12.2	12.0	14.6		125	51.7	183.6	169.1
15	-9.4	15.0	17.7		130	54.4	197.6	181.0
20	-6.7	18.4	21.0		135	57.2	212.4	193.5
25	-3.9	22.1	24.6		140	60.0	227.9	206.6
30	-1.1	26.1	28.5		145	62.8	244.3	220.3
35	1.7	30.4	32.6		150	65.6	261.4	234.6
40	4.4	35.0	37.0		155	68.3	279.5	249.5
45	7.2	40.0	41.7		160	71.1	298.4	265.1
50	10.0	45.3	46.7		165	73.9	318.3	281.4

**FIGURES WITH ASTERISKS (\*) = IN. HG. VACUUM**  
**FIGURES WITHOUT ASTERISKS = PSIG**

## R-134a HEALTH AND SAFETY INFORMATION

---

### Inhalation Toxicity

HFC-134a poses no acute or chronic hazard when it is handled in accordance with DuPont recommendations and when exposures are maintained at or below the DuPont Acceptable Exposure Limit (AEL) of 1,000 ppm (8 and 12 hour Time-Weighted Average or TWA).

An AEL is an airborne exposure limit established by DuPont scientists that specifies time-weighted average (TWA) airborne concentrations to which nearly all workers may be repeatedly exposed without adverse effects. The AEL for HFC-134a has the same value as the Threshold Limit Values (TLVs) established for CFC-12 and HCFC-22. TLVs are established by the American Conference of Governmental and Industrial Hygienists (ACGIH).

However, inhaling high concentrations of HFC-134a vapor may cause temporary central nervous system depression with narcosis, lethargy and anesthetic effects. Other effects that may occur include dizziness, a feeling of intoxication and a loss of coordination. Continued breathing of high concentrations of HFC-134a vapors may produce cardiac irregularities (cardiac sensitization), unconsciousness, and with gross overexposure, death. Intentional misuse or deliberate inhalation of HFC-134a may cause death without warning. This practice is **extremely dangerous**.

If you experience any of the initial symptoms, move to fresh air and seek medical attention.

### Cardiac Sensitization

If vapors are inhaled at a concentration of 75,000 ppm, which is well above the AEL, the heart may become sensitized to adrenaline, leading to cardiac irregularities and, possibly, to cardiac arrest. The likelihood of these cardiac problems increases if you are under physical or emotional stress.

Medical attention must be given immediately if exposed to high concentrations of HFC-134a. **DO NOT** treat with adrenaline (epinephrine) or similar drugs. These drugs may increase the risk of cardiac arrhythmias and cardiac arrest. If the person is having difficulty breathing, administer oxygen. If breathing has stopped, give artificial respiration.

---

## Spills Or Leaks

If a large release of vapor occurs, such as from a large spill or leak, the vapors may concentrate near the floor or low spots and displace the oxygen available for breathing, causing suffocation.

Evacuate everyone until the area has been ventilated. Use blowers or fans to circulate the air at floor level. DO NOT reenter the affected area unless you are equipped with a self-contained breathing apparatus or unless an area monitor indicates that the concentration of HFC-134a vapors in the area is below the AEL.

Always use self-contained breathing apparatus or an air-line mask when entering tanks or other areas where vapors might exist. Use the buddy system and a lifeline. Refer to the Material Safety Data Sheet (MSDS) for HFC-134a for more information.

HFC-134a vapors have a slightly sweet odor that can be difficult to detect. Therefore, frequent leak checks and the installation of permanent area monitors may be necessary in enclosed spaces. Refer to ASHRAE Standards 15 and 34 for refrigeration machinery rooms.

To ensure safety when working with HFC-134a in enclosed areas:

1. Route relief and purge vent piping (if present) outdoors, away from air intakes.
2. Make certain area is well ventilated, using auxiliary ventilation, if necessary, to move vapors.
3. Make sure area is clear of vapors prior to beginning work.
4. Install air monitoring equipment to detect leaks.

## Skin And Eye Contact

At room temperature, HFC-134a vapors have little or no effect on the skin or eyes. However, in liquid form, HFC-134a can freeze skin or eyes on contact, causing frostbite. Following contact, soak the exposed area in lukewarm water, not cold or hot. If medical treatment cannot begin immediately, apply a light coat of a nonmedicated ointment, such as petroleum jelly. If the exposed area is in a location where the presence of the ointment would be awkward, such as on the eye, apply a light bandage. In all cases of frostbite, seek medical attention as soon as possible.

**Always** wear protective clothing when there is a risk of exposure to liquid HFC-134a. Where splashing is possible, **always** wear eye protection and a face shield.

## Combustibility Of Hfc-134a

HFC-134a is nonflammable at ambient temperatures and atmospheric pressure. However, tests have shown HFC-134a to be combustible at pressures as low as 5.5 psig (139.3 kPa absolute) at 177°C (350°F) when mixed with air at concentrations generally greater than 60% volume air. At lower temperatures, higher pressures are required for combustibility. (HCFC-22 is also combustible at pressures above atmospheric in the presence of high air concentrations). Test results and calculations have shown:

- At ambient temperature, all concentrations of HFC-134a in air are nonflammable at pressures below 15 psig (205 kPa absolute).
- Combustible mixtures of air and HFC-134a will not form when liquid HFC-134a is pumped into closed vessel if initial air pressure in vessel is limited to one atmosphere absolute and final pressure is limited to 300 psig (2,170 kPa absolute). If initial air pressure is greater than one atmosphere, combustible mixtures may form as tank is filled.

Based on above information, the following operating practices are recommended:

## Leak Testing

- ~~Equipment should~~ **NEVER** be leak tested with a pressurized mixture of HFC-134a and air. HFC-134a may be safely pressured with dry nitrogen.

## Bulk Delivery and Storage

- Tanks should normally be evacuated at start of filling, and should never be filled while under positive air pressure.
- Tank pressure should never be allowed to exceed 300 psig (2,170 kPa) when filling with HFC-134a. Relief devices on either tanks or HFC-134a supply system usually prevent this.
- Tank pressures should be monitored routinely.
- Air lines should never be connected to storage tanks.

## Filling and Charging Operations

- Before evacuating cylinders or refrigeration equipment, any remaining refrigerant should be removed by recovery system.
  - Vacuum pump discharge lines should be free of restrictions that could increase discharge pressures above 15 psig (205 kPa) and result in formation of combustible mixtures.
  - Cylinders or refrigeration equipment should normally be evacuated at start of filling, and should never be filled while under positive air pressure.
  - Final pressures should not exceed 300 psig (2,170 kPa).
-

- Filled cylinders should periodically be analyzed for air (nonabsorbable gas or NAG).

## Refrigerant Recovery Systems

Efficient recovery of refrigerant from equipment or containers requires evacuation at the end of the recovery cycle. Suction lines to a recovery compressor should be periodically checked for leaks to prevent compressing air into the recovery cylinder during evacuation. In addition, the recovery cylinder pressure should be monitored, and evacuation stopped in the event of a rapid pressure rise indicating the presence of noncondensable air. The recovery cylinder contents should then be analyzed for NAG, and the recovery system leak checked if air is present. **DO NOT** continue to evacuate a refrigeration system that has a major leak.

## Thermal Decomposition

HFC-134a vapors will decompose when exposed to high temperatures from flames or electric resistance heaters. Decomposition may produce toxic and irritating compounds, such as hydrogen fluoride. The pungent odors released will irritate the nose and throat and generally force people to evacuate the area. Therefore, it is important to prevent decomposition by avoiding exposure to high temperatures.

---

## REAR MOUNTED ICE MAKER FOR COUNTER DEPTH MODEL REFRIGERATORS

The automatic Ice Maker is mounted in the freezer compartment. It is attached to a bracket extending up from the back of the Auger motor cover.

The Ice Maker is designed to produce ice automatically. The length of time between Harvest Cycles will vary, depending on load conditions, door openings, ambient temperature and freezer temperature. These factors must be taken into consideration when checking the ice production rate.

With a temperature of  $-2^{\circ}\text{F}$  to  $+5^{\circ}\text{F}$  in the freezer, the rate of harvest will be 8 - 12 cycles per 24 hour period.

The Ice Maker is wired across the line and will harvest ice in the refrigeration or defrost cycles.

The Water Valve and Solenoid Assembly are both mounted in the compressor compartment.

A tube extends from the water valve up the rear wall of the refrigerator to a water inlet spout that directs the water into the fill trough. The water fill spout will twist lock into a housing in the back of the refrigerator and direct water flow into the ice maker from the side of the mold.

### Front Cover

A decorative front cover, made of molded plastic, encloses the operating mechanism of the Ice Maker, protecting it from moisture. It is essential that the cover be in place on an operating Ice Maker to protect against possible contact with the mechanism by the user. (See Figure F1)

### Ice Mold

The Ice Mold is die-cast aluminum with the Ice Maker Thermostat bonded to its front surface. The Mold has a semi-circular interior partitioned into equal size compartments. Water enters at the side of the Mold, through a fill trough. A film of silicon grease on the top edge of the Mold prevents siphoning of water by capillary action.

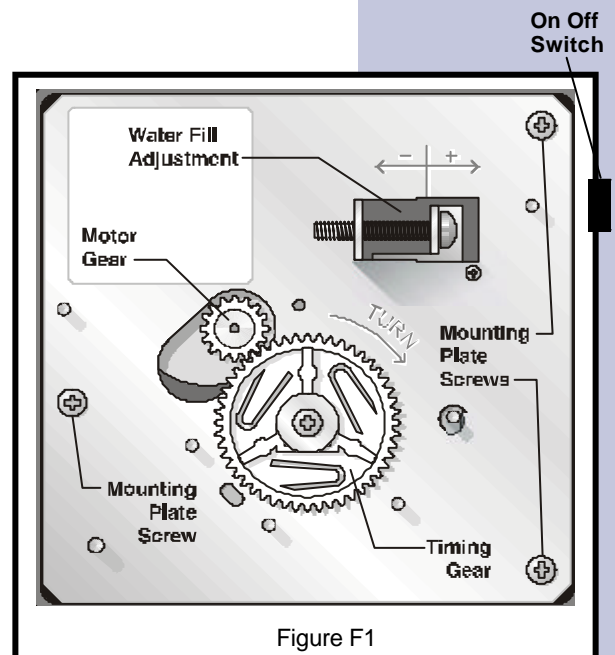

# 84 Section F - Ice Maker

---

## Mold Heater

A Mold Heater, rated at 120 watts at 110volts, 110 ohms  $\pm$  10% or 120 watt at 230 volts, 340 ohms  $\pm$  10%, and covered with an aluminum sheath, is embedded in the grooved section on the underside of the Mold. When the Mold Heater is energized, the ice contact surface within the Mold is heated enough to allow harvest of the ice pieces.

The Mold Heater is wired in series with the Ice Maker Thermostat, which acts as a safety device.

The heater is staked in place, and is replaced as part of the ice maker Mold.

A thermal mastic sealer is placed between the heater and the Mold to ensure good thermal contact.

## Ice Stripper

A Ice Stripper is attached to the Mold to prevent ice pieces from falling back into the Mold. It also serves as a decorative side cover.

## Ice Ejector

The Ejector blades are molded from Delrin, and extend from a central shaft, which turns in nylon bearings at the front and rear. Each blade sweeps an ice section out of the Mold. The drive end of the Ice Ejector is "D" shaped. Food Grade Silicone grease is used to lubricate the bearing surfaces.

## Water Valve Assembly

The Water Valves are solenoid operated and when energized, releases water from the water tank in the food compartment into the Ice Mold. The amount of water released is directly proportional to the length of time the Water Valve Switch is energized. A flow washer, inside the Water Valve, maintains a constant rate of water flow over a supply line pressing ranging from 20 to 100 psig. It will not compensate for pressures below 20 psig, or greater than 100 psig. A No. 80-mesh screen, placed ahead of the flow washer, filters out foreign materials.

The solenoid coil draws 20 watts of power. The coils are wired in series with the Mold Heater, across the supply voltage.

## Thermostat

The Thermostat is a single-pole, single throw (SPST), bimetallic, disk-type, thermal switch. It automatically starts the Harvest Cycle when the ice is frozen. The Thermostat closes at a temperature of  $18^{\circ}\text{F} \pm 6^{\circ}$ . Wired in series with the Mold Heater, the Thermostat acts as a safety device against overheating in the event of

---

mechanical failure. A thermal mastic bond is provided where the Thermostat is mounted against the Mold. A gasket prevents water from leaking into the support housing.

## Sensing Arm & Linkage

The Sensing Arm is cam-driven and operates a switch that controls the quantity of ice produced. In the Harvest Cycle, the arm is raised and lowered during each of the two revolutions of the timing cam. If the Sensing Arm comes to rest on top of ice in the storage compartment during either revolution, the switch will remain open and stop the Ice Maker at the end of that revolution. When sufficient ice is removed from the Storage Container, the Sensing Arm lowers and ice production resumes. To manually stop the Ice Maker, raise the Sensing Arm until it locks in the upper position or turn the switch located on the housing at the left end of the icemaker to off. Operation is resumed when the Sensing Arm is manually lowered or the switch is turned back to on.

## Timing Switches (See Figure F2)

The three Timing Switches used are single-pole, double throw (SPDT). They are identical except for function, and can be used interchangeably.

1. **Hold Switch** - Assures completion of a revolution once the Ice Maker operation has started.
2. **Water Fill Switch** - Opens the Water Valve during the Fill Cycle. It is the only adjustable component in the Ice Maker.
3. **Shut-Off Switch** - Stops Ice Maker operation when the Storage Container is full of Ice. The switch is opened after the Sensing Arm is raised to its most upright position. The switch is mounted to the top right wall of the Ice Maker Support. (Not shown in Figure F2)

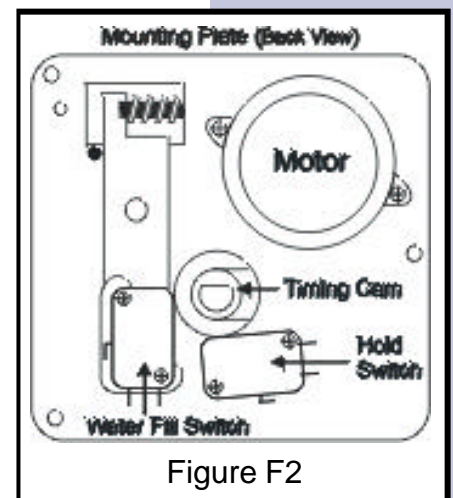

Figure F2

## Thermal Cut-Out (TCO)

The Thermal Cut-Out is a one-time limit fuse used as a safety device. It is located under the mounting plate, in the head of the Ice Maker, between the Thermostat and wire connector.

If the Thermal Cut-Out opens, the cause of failure must be determined and corrected prior to replacing the TCO. Normal causes of the TCO failing are a bad Thermostat or a shorted coil on the water valve.

### Timing Cam & Coupler

Three separate cams are combined in one molded Delrin part:

1. Inner Cam operates Shut-Off Switch lever arm.
2. Center Cam operates Hold Switch.
3. Outer Cam operates Water Fill Switch.

One Cam end is attached to a large Timing Gear. The other Cam end is coupled to the Ejector.

### Timing Gear

This large molded plastic gear is driven by the Motor and, in turn, rotates the Cam and Ejector. A “D” shaped hole in the gear fits over the Timing Cam Hub. Spacer tabs on the backside of the gear prevent the gear from binding on the mounting plate.

### Motor

A low wattage, stall-type Motor drives the Timing Gear. This gear turns the Timing Cam and Ejector Blades approximately one revolution every three minutes (1/3 RPM).

### On / Off Switch

There is a single switch mounted on the right side of the housing at the front of the ice maker. This switch is used to turn the ice maker off. Unlike the switch on the bail arm the On/Off switch will stop the ice maker as soon as it is pushed, it will not allow the ice maker to complete the revolution. This switch can also be used to start the icemaker into a Harvest cycle

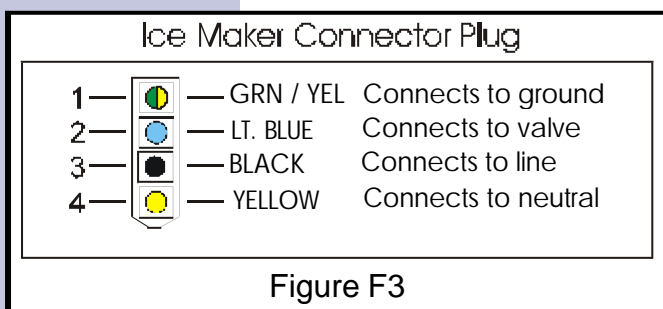

### Wiring

A four-prong plug connects the Ice Maker wiring to the cabinet wiring harness. (See Figure F3.) The Ice Maker Assembly is wired across the line and will harvest in either the Refrigeration or Defrost Cycles. A wiring diagram is located inside the front cover of the Ice Maker. The correct water fill volume is 78-83 cc. To measure

the fill volume, test-cycle the Ice Maker and collect the water. Measure in a container calibrated in cubic centimeters (cc) the fill time is 5.4 seconds.

The fill volume is adjusted by increasing or decreasing the length of time the Water Fill Switch remains closed.

## Installing Water Supply Line To Ice Maker

Supply line installation must comply with all applicable plumbing codes. Refer to the **Ice Maker Installation Instructions** in appendix A.

The ¼" tubing, and any other plumbing materials required, should be obtained locally.

The Ice Maker should be connected to a frequently used cold water line to ensure a fresh water supply.

### NOTE

A vertical cold water line should be selected for the water supply. If a vertical line is not available, a horizontal line may be used, providing the connection is on the side or top of the pipe, but not on the bottom. Scale and foreign material in the pipe could cause stoppage of water flow if the connection is on the bottom.

Be sure to leak test all connections after the water supply has been turned on.

## Test Cycling Ice Maker (See *Ice Maker Testing Procedures* on page 94).

It may be necessary, on occasion, to test-cycle an Ice Maker to check its operation. This can be done on the repair bench or while mounted in the Refrigerator.

If the Ice Maker is in an operating refrigerator, take precautions against the formation of condensate by allowing the cold, metal components to warm up before removing the front cover. This can be expedited by cycling the assembly with the cover in place and the water supply valve closed.

To manually cycle the Ice Maker, push the ON/OFF switch to the ON position and hold until the Ejector blades turn clockwise until the Hold Switch circuit to the Motor is completed. When the Motor starts, all components except the Ice Maker Thermostat should perform normally. Once the Ice Maker completes its cycle, if additional testing is necessary you can turn the Ejector blades again to start the icemaker inot another cycle.

## Water Valve Switch – Water Fill Volume

The amount of water fill is directly proportional to the length of time terminals “C-NC” of the Water Fill Switch are closed. Closing occurs when the switch plunger drops into a cavity formed in the Cam.

Different water valves have different flow rates. For this reason, anytime a Water Valve is replaced, the Water Fill Switch must be adjusted.

The correct water fill volume is 78-83 cc. To measure the fill volume, test-cycle the Ice Maker and collect the water. Measure in a container calibrated in cubic centimeters (cc) the fill time is 5.4 seconds.

The fill volume is adjusted by increasing or decreasing the length of time the Water Fill Switch remains closed.

To adjust the Water Fill Switch, first determine how much water is needed. The adjusting screw is calibrated so that one complete revolution changes the water fill about 18 cubic centimeters. Turning the screw clockwise decreases the fill, while turning counterclockwise increases the fill.

**EXAMPLE:** An Ice Maker is test-cycled and the water fill sample is 93 cubic centimeters. Subtracting 80 cc from 93, the adjustment needed is 13 cc. Since one turn of the adjusting screw changes the fill 18 cc,  $\frac{3}{4}$  of a turn clockwise would reduce the fill about 13 cc, the desired amount. (This example is for manual models only.)

### Parts Replacement

Disconnect electrical supply to refrigerator. If the

#### To Replace Front Cover (See Figure F4)

1. Remove ice from freezer.
2. Ensure that Ice Maker is at room temperature before removing Cover.
3. Place straight blade of screwdriver in slot at bottom of Mold Support and pry Cover loose.

### NOTE

Ensure that the retaining tabs inside the Cover are located on the top and bottom when installing the Cover.

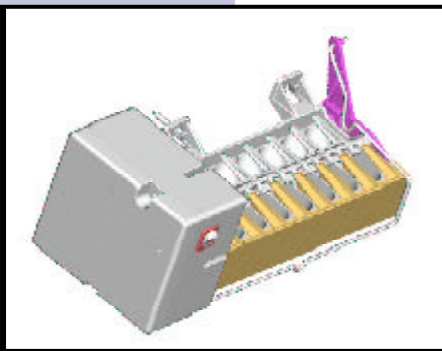

4. Snap Cover in place.

#### To Replace Fill Trough and Bearings

1. Remove Ice Maker from Freezer.
2. Push Trough retaining tab back away from Mold.
3. Rotate Trough counterclockwise until it is clear.
4. Pull from back to detach from Mold and Ejector Blades.
5. Replace in reverse order.

## To Replace Ice Stripper

1. Remove Ice Maker from Freezer.
2. Remove Ice Maker from refrigerator.
3. Push out on retention tab of mold.
4. Pull back on Ice Stripper to disengage it from front of Mold Support housing.
5. Replace in reverse order.

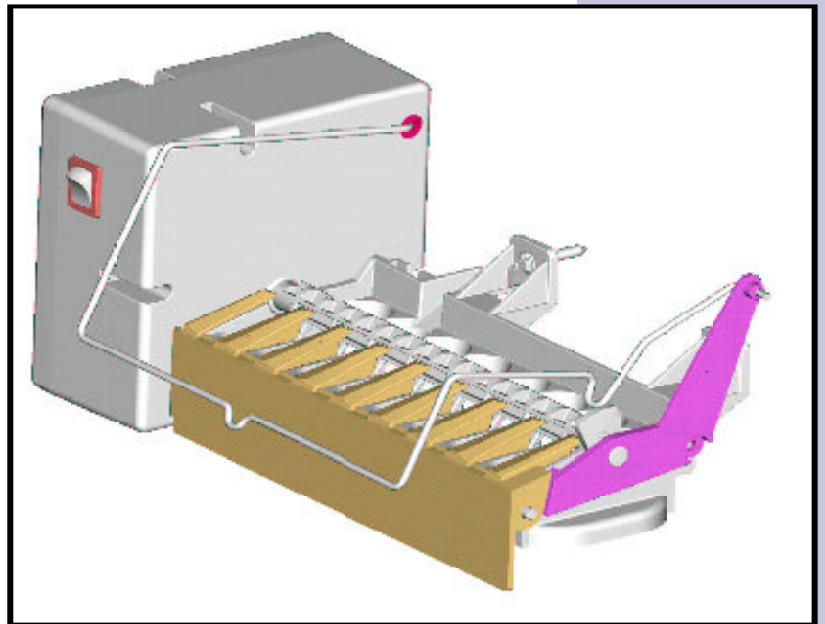

## To Replace Motor and Switch Mounting Plate

1. Remove Ice Maker from Freezer.
2. Remove front Cover.
3. Remove three screws that attach Mounting Plate to Support Housing.
4. Carefully remove Mounting Plate, disengaging end of Sweep Arm and noting relative position of Sweep Arm Spring.
5. Transfer Motor, Switches, Cam, Gear, and Water Fill Adjusting Spring and Arm to replacement Mounting Plate.
6. Attach new Mounting Plate to Support Housing with three screws.

### NOTE

Ensure that the wiring harness is properly positioned and the Sweep Arm is in place.

7. Check Water Fill Cycle and adjust as required.
8. Replace front Cover.

## To Replace Motor

1. Remove Ice Maker from Freezer.
2. Remove front Cover.
3. Remove three screws that attach Mounting Plate to Support Housing.
4. Disconnect two Motor leads.
5. Remove two Motor mounting screws.

### To Replace Water Fill Switch

1. Remove Ice Maker from Freezer.
2. Remove front Cover.
3. Remove three screws that attach Mounting Plate to Support Housing.
4. Disconnect two Water Fill Switch wire leads.
5. Remove two switch mounting screws.
6. Remove switch.
7. Replace switch in reverse order, ensuring that switch insulator is in place.
8. Check Water Fill Cycle and adjust as required.

### To Replace Ejector Blades

1. Remove Ice Maker from Freezer.
2. Remove front Cover.
3. Remove three screws holding Mounting Plate in place.
4. Carefully remove Mounting Plate, disengaging end of Ice Maker Control Arm and Ejector Blades from Motor coupling, noting relative position of Ice Maker Control Arm Spring.
5. Remove Fill Trough and bearing.
6. Turn blades to 12 O'clock position.
7. Slide Ejector Blades back and up to remove.
8. Replace in reverse order.
9. Lubricate bearing ends of Ejector with Silicone grease.

### To Replace Hold Switch

1. Remove Ice Maker from Freezer.
  2. Remove front Cover.
  3. Remove three screws that attach Mounting Plate to Support Housing.
  4. Disconnect six Hold Switch wire leads.
  5. Remove two Hold Switch mounting screws.
  6. Remove Hold Switch.
  7. Replace in reverse order.
-

## To Replace Ice Maker Control Arm Shut-OFF Switch

1. Remove Ice Maker from Freezer.
2. Remove front Cover.
3. Remove three screws that attach Mounting Plate to Support Housing.
4. Disconnect three Ice Maker Control Arm Shut-Off Switch wire leads.
5. Raise Ice Maker Control Arm Lever.
6. Remove two Ice Maker Control Arm Shut-Off Switch mounting screws.
7. Remove switch.
8. Replace switch in reverse order.

## To Replace Ice Maker Thermostat

1. Remove Ice Maker from Freezer.
2. Remove front Cover.
3. Remove three screws that attach Mounting Plate to Support Housing.
4. Loosen two Thermostat retaining clip mounting screws.
5. Disconnect two thermostat wire leads and remove thermostat.
6. Apply thermal mastic sealer to sensing surface of replacement thermostat to ensure a positive bond to mold.
7. Replace thermostat in reverse order.

## To Replace Thermal Cut-Out (TCO)

1. Remove Ice Maker from Freezer.
  2. Remove front Cover.
  3. Remove three screws that attach Mounting Plate to Support Housing.
  4. Pull cable assembly free from support housing. It will slide out easily.
  5. Loosen screw securing clamp to TCO. TCO should come free after tension from clamp is released.
  6. Disconnect TCO from two wire nuts. One end is connect to the cable assembly and the other end is connected to the motor and mold heater.
  7. Replace with new TCO.
  8. Reassemble in reverse order.
-

# 92 Section F - Ice Maker

## To Replace Mold Heater

1. Remove Ice Maker from Freezer.
2. Remove front Cover.
3. Remove Ice Stripper. (Refer to Section "To Replace Ice Stripper" on page 89)
4. Remove three screws that attach Mounting Plate to Support Housing.
5. Remove three screws that attach Mold to Support Housing.

### NOTE

One of the three screws is attached to the two Green/Yellow ground wires and another one is holding the Clamp in place. The third screw is located in the lower right corner of the Support Housing.

6. Unscrew wire nut holding three black leads together and separate them.

### NOTE

One black lead is connected to the Mold Heater. Another is connected to the Thermostat and the third lead goes to the Hold Switch.

7. Disconnect remaining Mold Heater lead connected to brown Motor lead and black Thermal Cut-Out lead.
8. Separate Mold from Support Housing.

### NOTE

Be careful not to destroy the thermostat gasket located between the mold and support housing.

9. Remove hex head screw holding Ice Maker Leveling Bracket to Mold.

### NOTE

The Mold is crimped in six places, holding the Mold Heater firmly in the Mold groove. It may be necessary to use a hammer and screwdriver to remove the heater from the Mold groove.

10. Use a flat-bladed screwdriver to pry inoperative heater from Mold groove.
11. Clean remaining thermal mastic sealer from Mold groove.
12. Apply layer of thermal mastic sealer to Mold groove.
13. Install replacement Mold Heater.
14. Replace parts in reverse order. Ensure that Thermostat gasket is in place. Bond the Thermostat to Mold with thermal mastic sealer.

### NOTE

For best operation, the freezer temperature should be between -2°F to +4°F.

## FAULT DIAGNOSIS

### Complaint - Ice Maker Fails to Start

1. Check to see if Ice Maker Control Arm is locked in raised position.
2. Check terminals from Cabinet wiring to Ice Maker for open circuit in wiring or components.
3. Check operation of the Maker with test service cord.
4. Check Mold temperature at a mounting screw. If temperature is above 15°F, freezer air temperature is not cold enough to switch Ice Maker Thermostat to closed position. If Mold is below 9°F, manually start Ice Maker by pushing ON/OFF switch to the ON position and holding for at least 2 seconds until the motor starts to rotate. If motor fails to start, check Motor for continuity. If Motor starts, Thermostat, Shut-Off Switch, or Hold Switch is inoperative.
5. Check Hold Switch first. With Ejector blades in the starting position, check terminals "C" and "NC" for continuity. Replace switch if continuity readings are open. Check Shut-Off Switch linkage. Then check terminals "NO" and "C" for continuity with Ice Maker Control Arm in lowest position. Replace switch if continuity readings are open. If Hold Switch and Shut-Off Switch are operative, then replace Thermostat.

### Complaint-Ice Maker Fails to Complete Cycle.

1. With Ejector blades at 10 o'clock position, Hold Switch Plunger depressed, Check terminals "C" and "NO" for continuity. Replace switch if continuity readings are open.
2. With Ejector blades at 12 o'clock position, check Shut-Off Switch terminals "C" and "NC" for continuity . Replace Thermostat if continuity readings are open.
3. With Ejector blades at 4 o'clock position, check Mold Heater and Ice Maker Thermostat for continuity. Replace heater if continuity readings are open. If heater shows continuity, replace Thermostat.
4. Check Motor operation with a test cord. Replace Motor if it fails to start.

### Complaint-Ice Maker Fail to Stop at End of Cycle

With the Ejector blades in the starting position, check the Hold Switch terminals "C" and "NO" for continuity. Replace the switch if the continuity readings are indicating a closed circuit.

# 94 Section F - Ice Maker

## Complaint-Ice Maker Continues to Eject When Container is Full.

1. Check for loose linkage to the Ice Maker Control arm Shut-Off Switch. Switch should open when arm is in raised position. Adjust, if required.
2. Check Shut-Off Switch terminals "C" and "NO" for continuity with Ice Maker Control Arm raised. Replace switch if continuity readings are indicating a closed circuit.

## Complaint-Ice Maker Produces Undersized Ice Pieces

1. Ensure that Ice Maker mold is level.
2. Check for partial restriction in supply line or Water Valve Strainer.
3. Ensure that the water pressure to Water Valve is sufficient. (20 psi min., 120 psi max.)
4. Ensure that the Water Valve Switch is adjusted for proper water fill, 78 to 83 cc's.
5. Check thermal bond between Thermostat and Mold. If necessary, rebond with thermal mastic sealer.

## ICE MAKER TESTING PROCEDURES

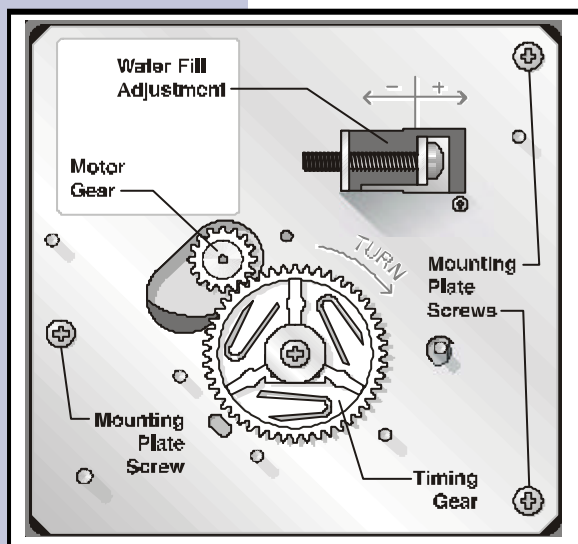

### Operating Cycle

The operation of the Ice Maker, water refilling, and controlled ice storage, require proper functioning and timing of all components.

Consider the following:

- Has refrigerator been properly installed and connected to sources of electrical power and water?
  - Has Freezer compartment Evaporator pulled down to temperature?
  - Have several ice making cycles been completed and is the Ice Maker in the Freeze Cycle?
  - Is the Ice Maker Thermostat single-throw switch in series with the Mold Heater?
- 
- Do the Ejector Blades make two revolutions per cycle? Is ice stored on blades after harvest?
  - Is the Water Solenoid wired in series with the Mold Heater?

## Operating Cycle Illustrations - Manual Cycle

To manually cycle Ice Maker, push ON/OFF switch to the ON position and hold down until the sweep arm advances to the 2 o'clock position. Then let go of switch. Let the Icemaker advance on it's own through a cycle.

## Operating Cycle Illustrations - Electrical

The following wiring diagrams illustrate the electrical operation of an Ice Maker. This procedure is on the Internet at <http://www.frigidaire.com/tip/>

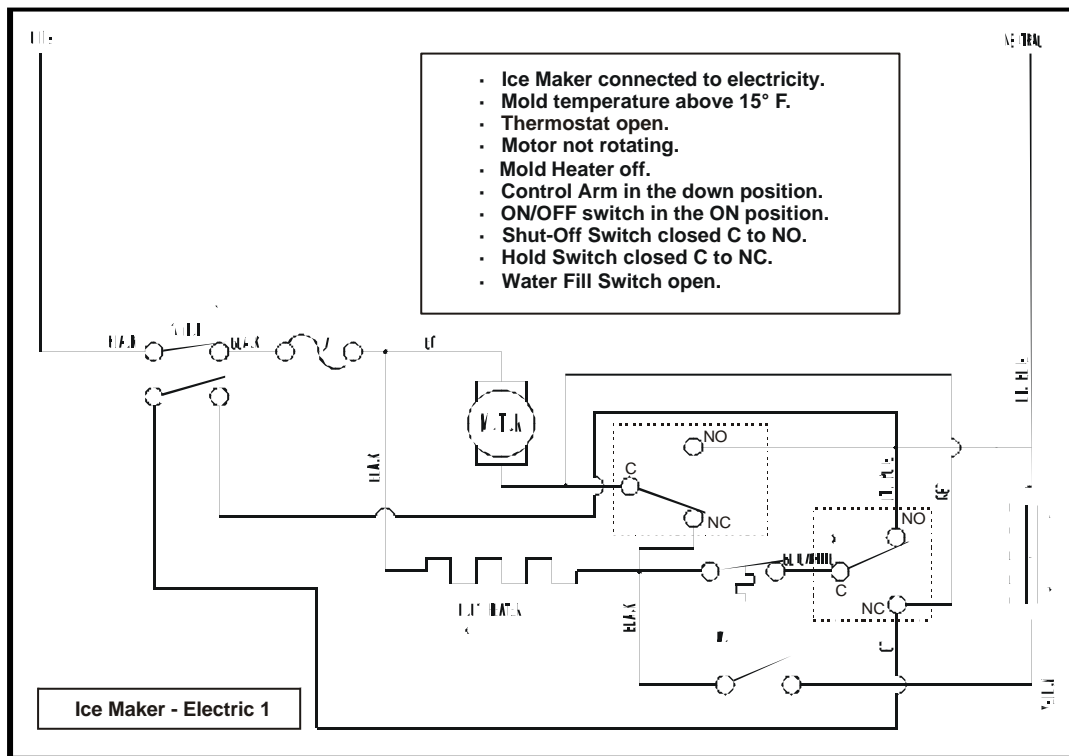

# 96 Section F - Ice Maker

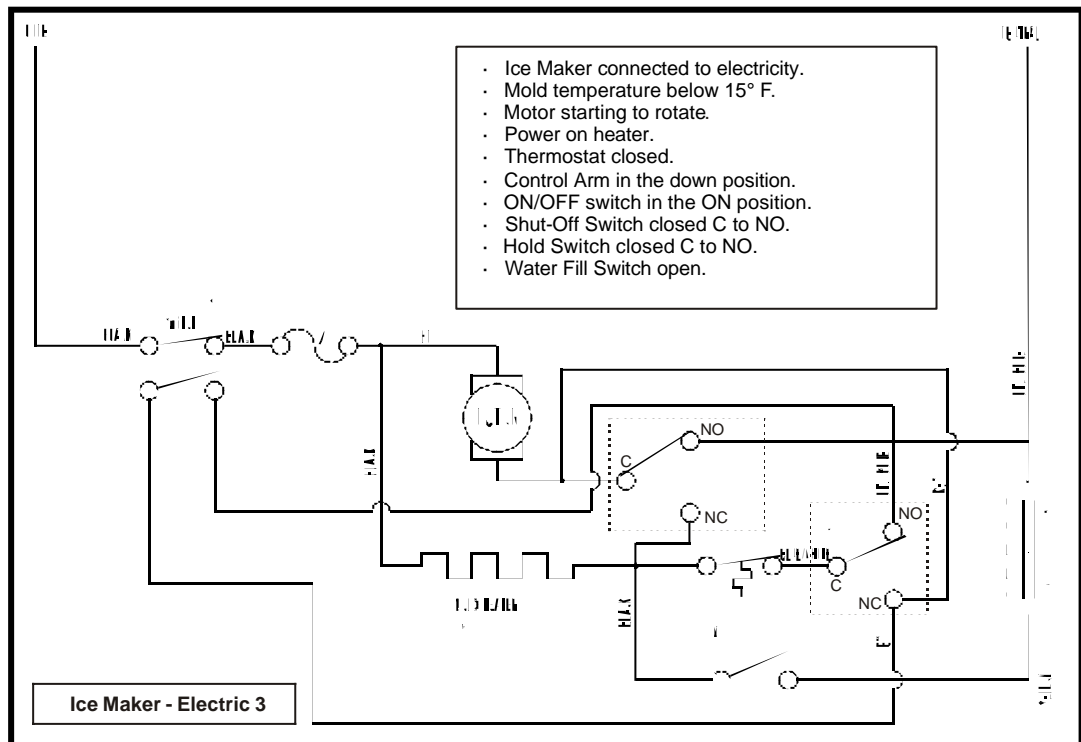
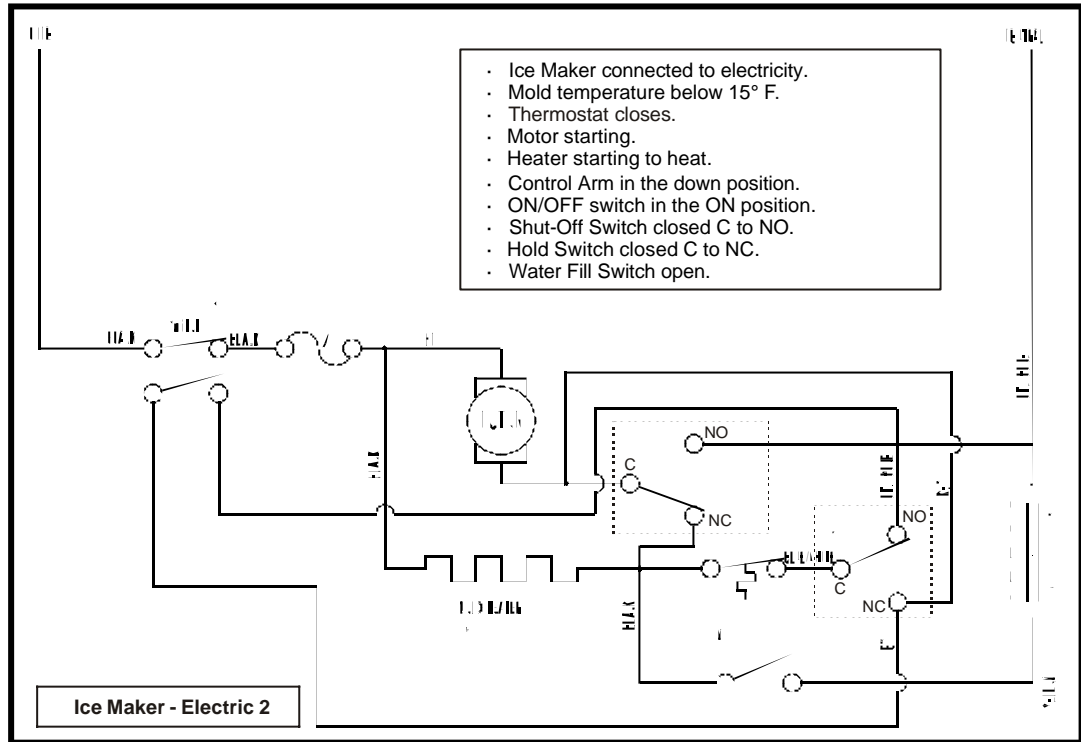

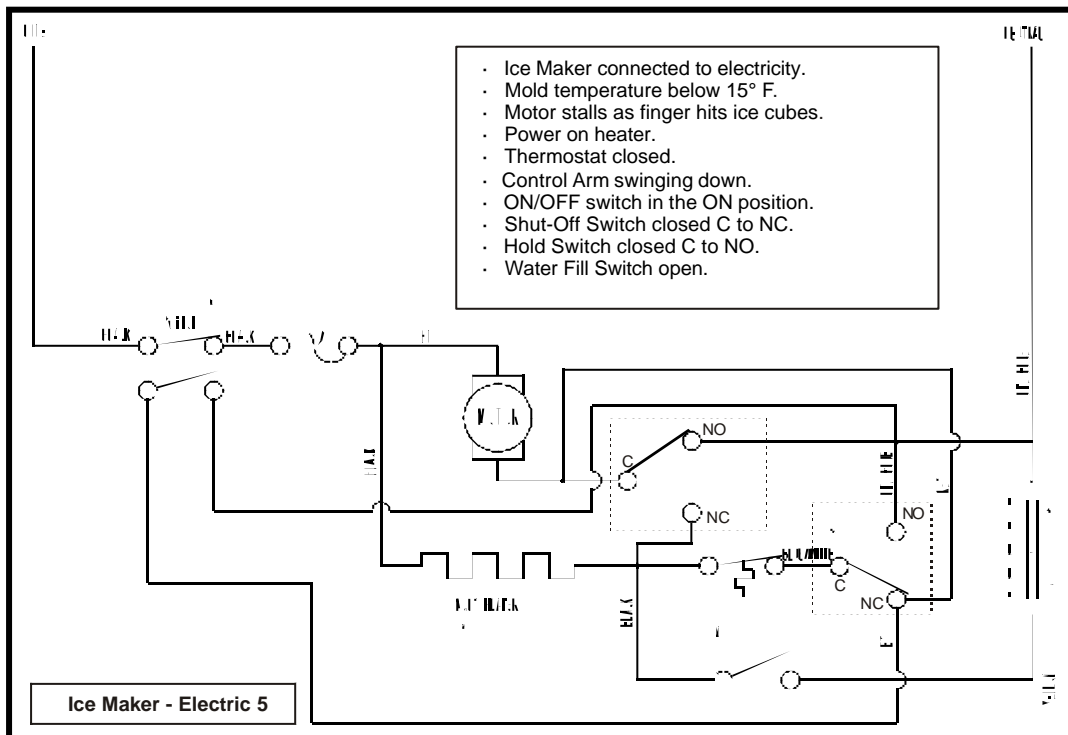
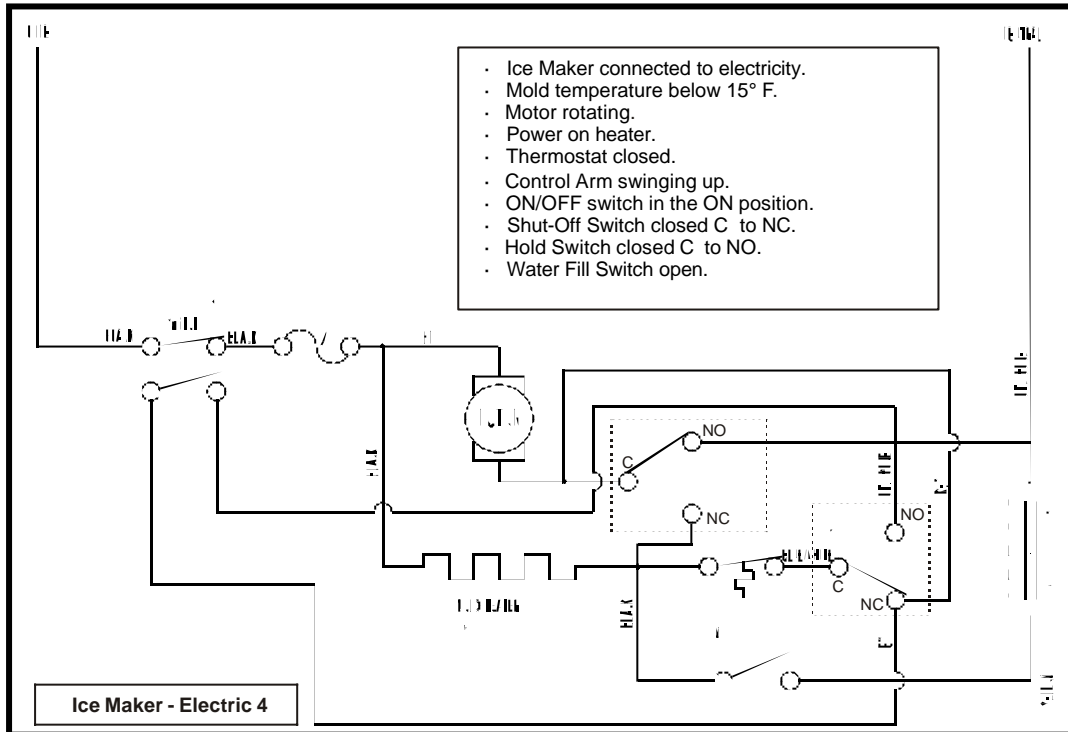

# 98 Section F - Ice Maker

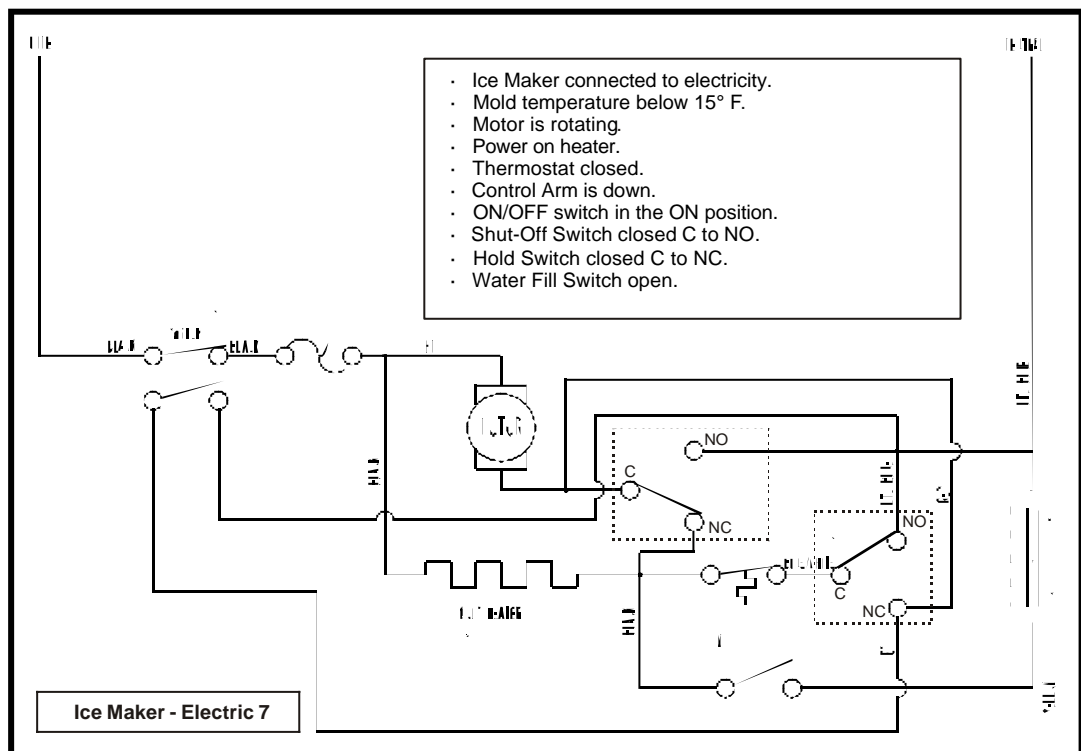
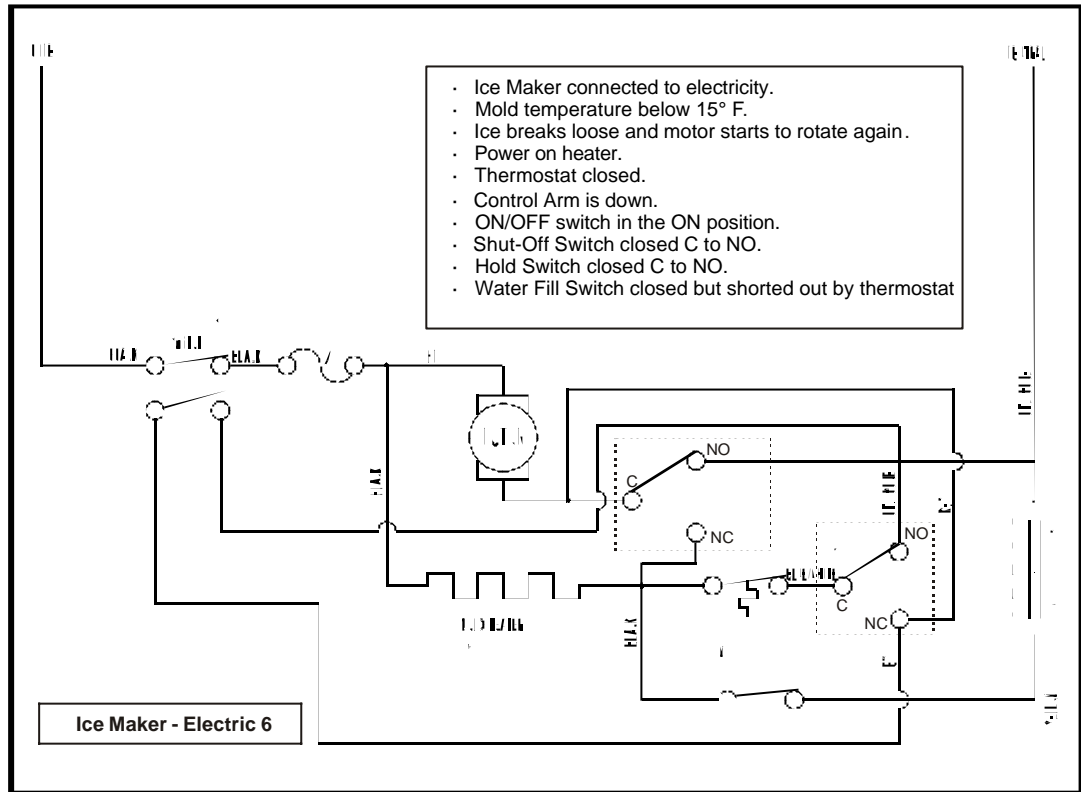

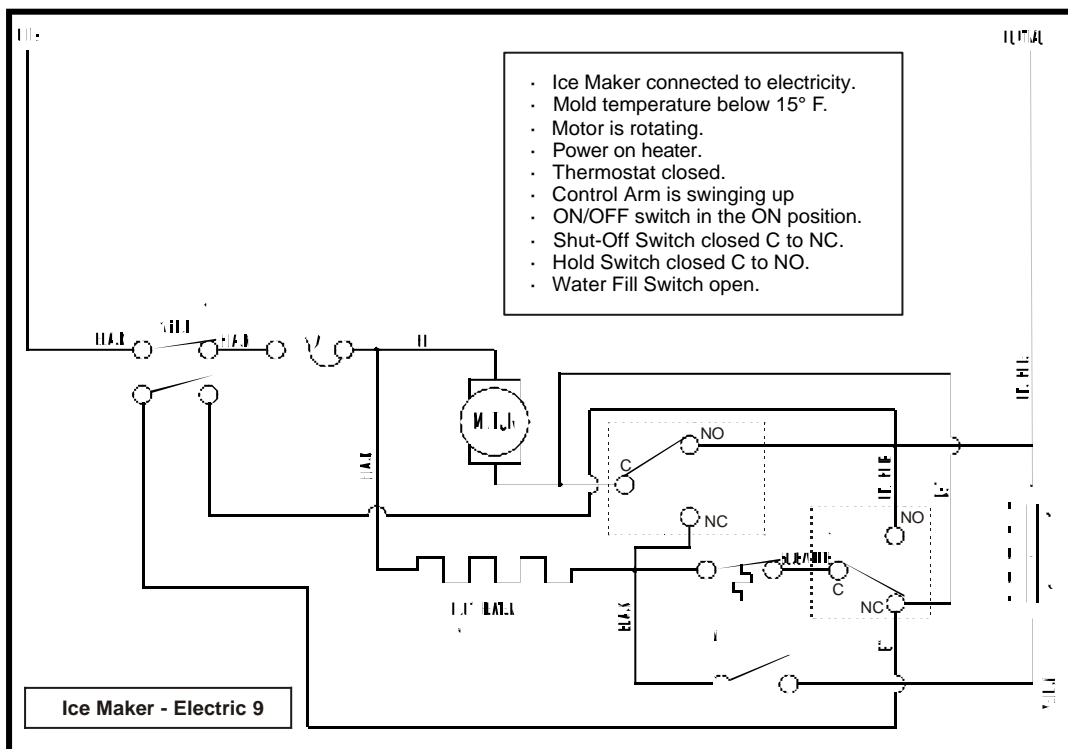
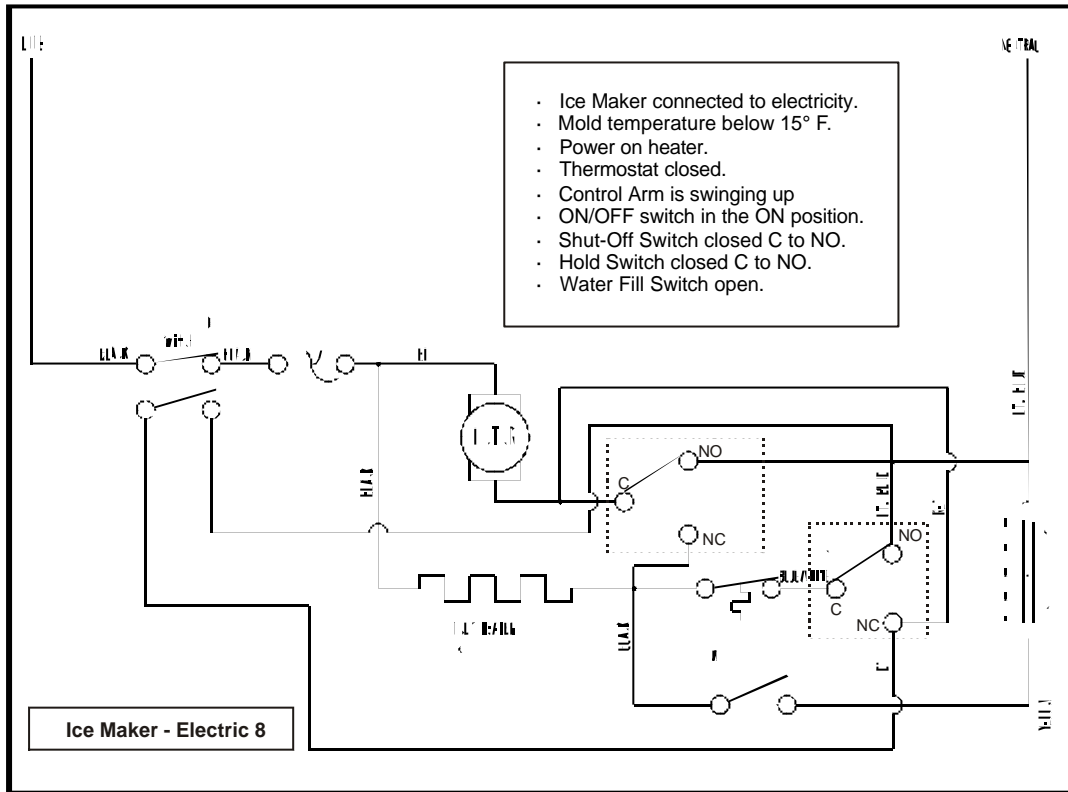

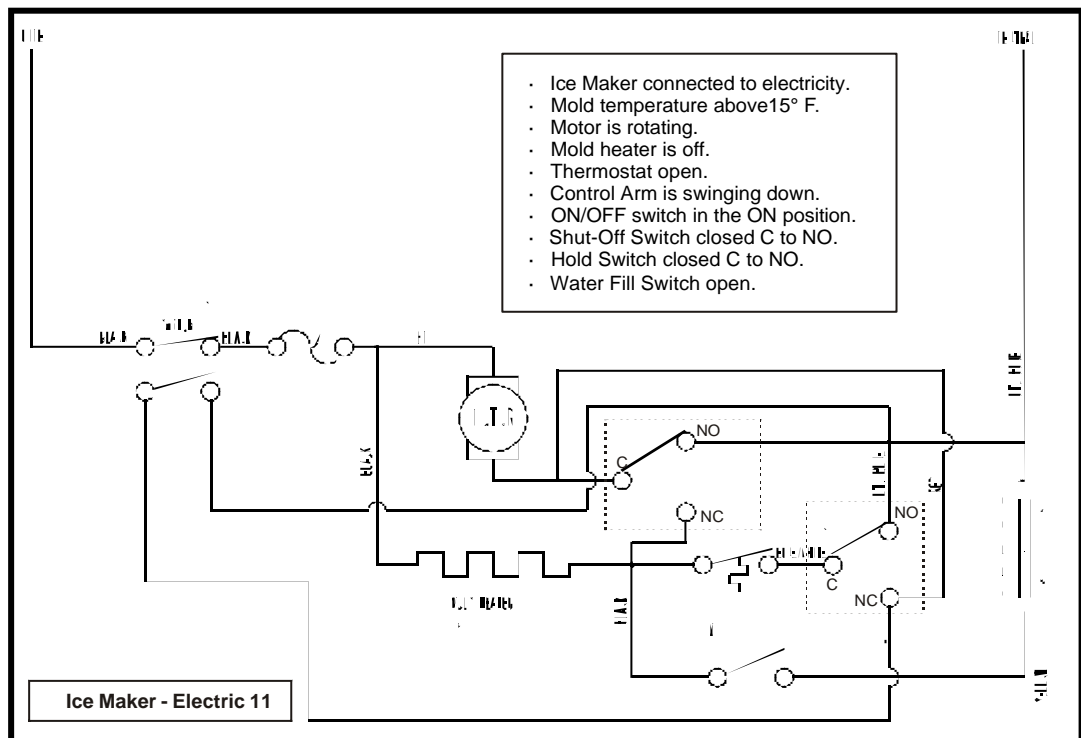
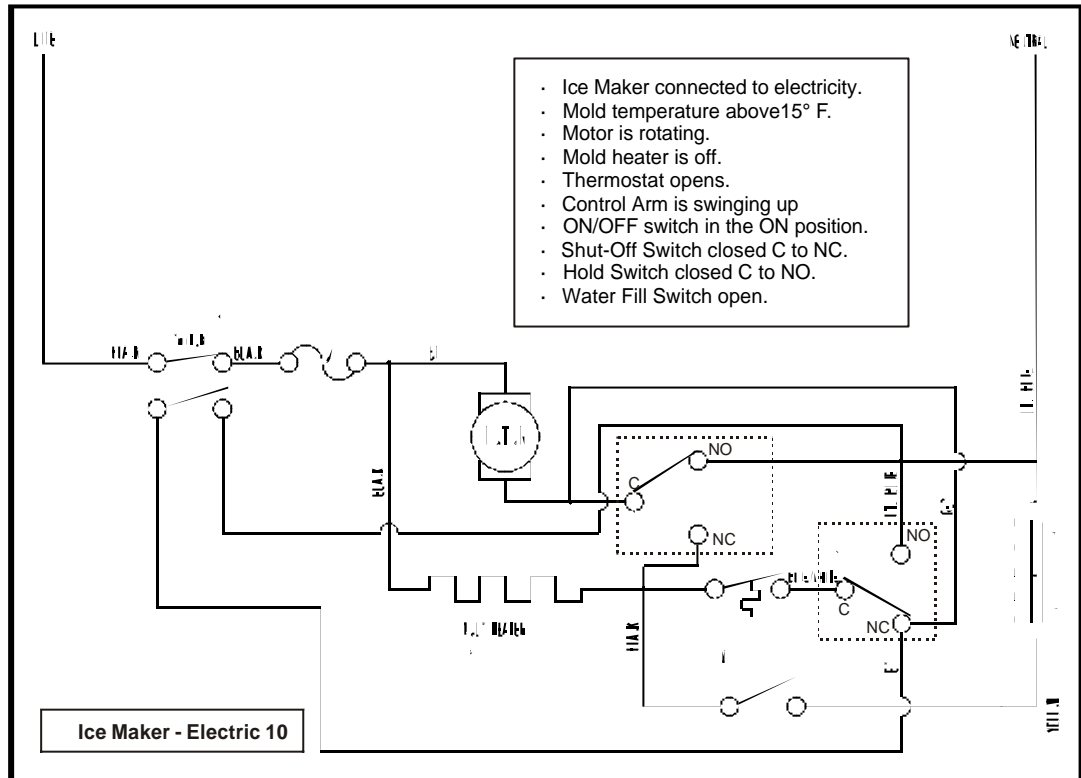

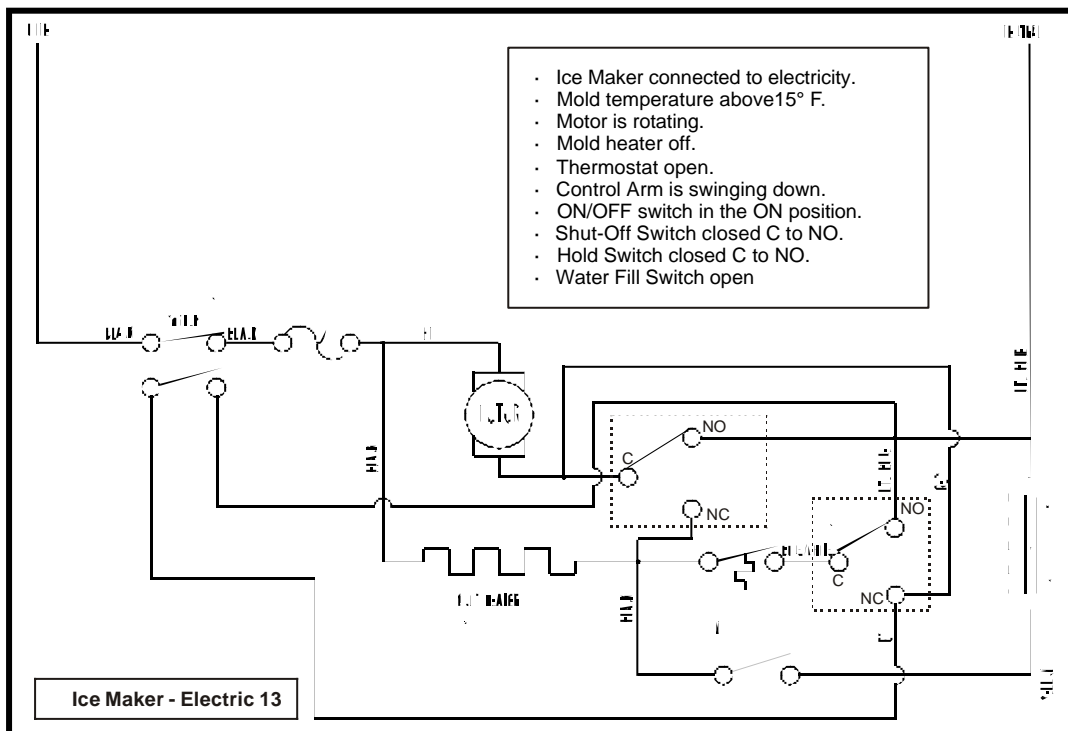
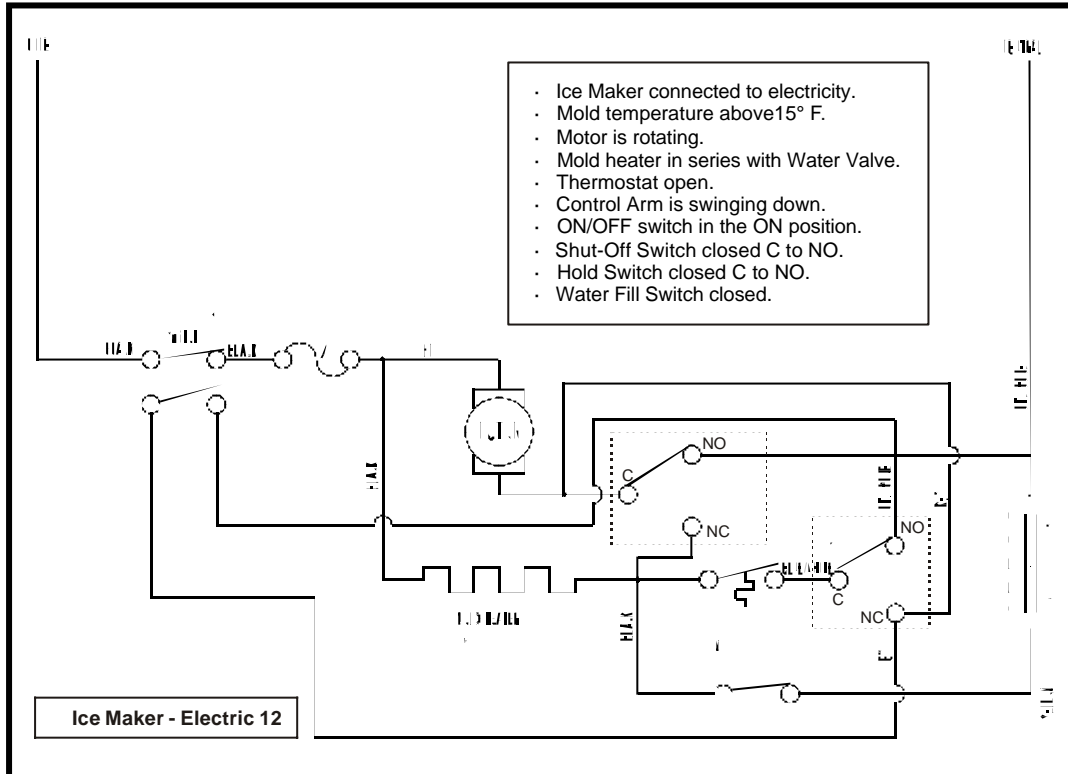

# 102 Section F - Ice Maker

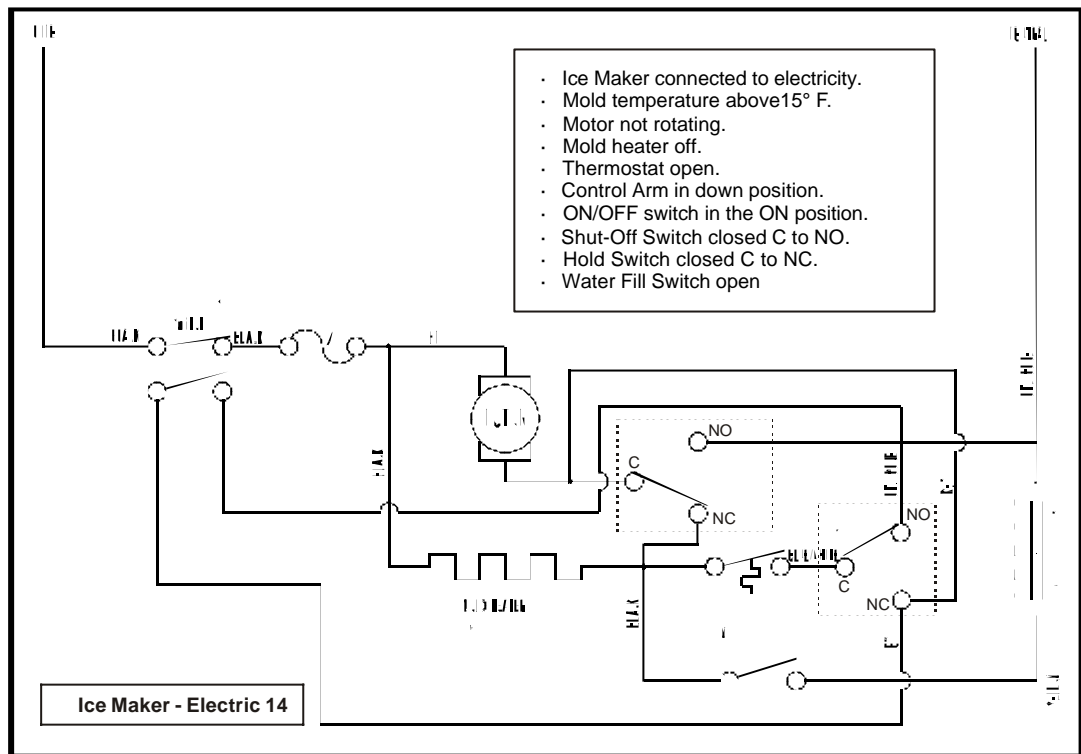

## Operating Cycle Illustrations - Mechanical

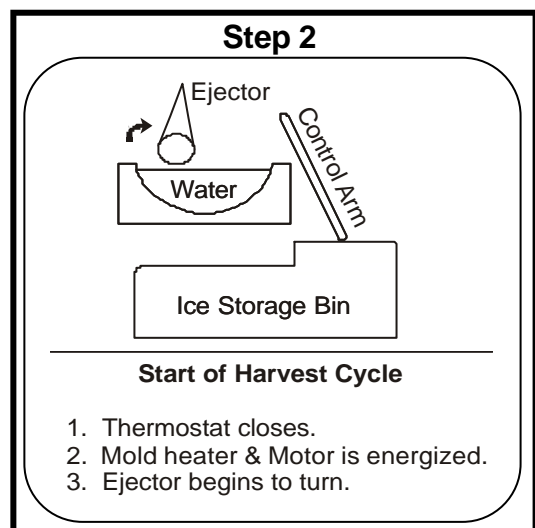
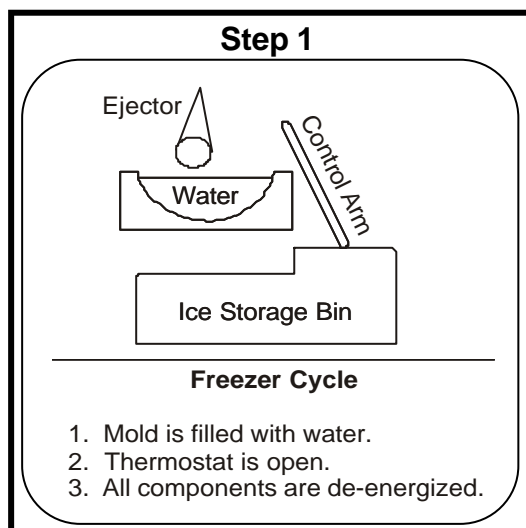

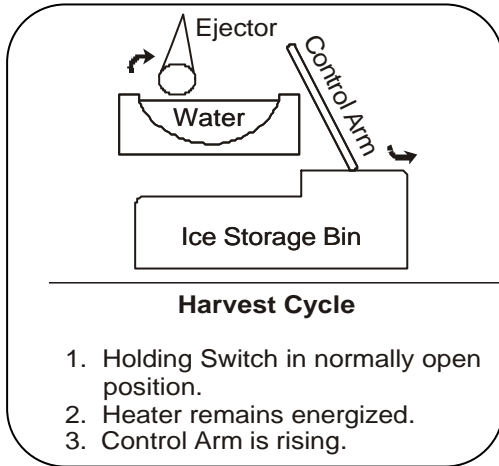

**Step 3**

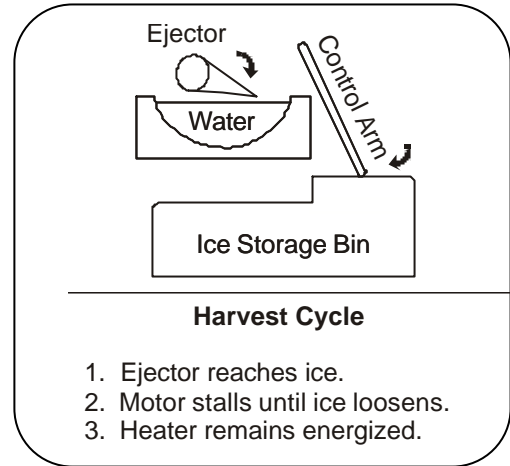

**Step 4**

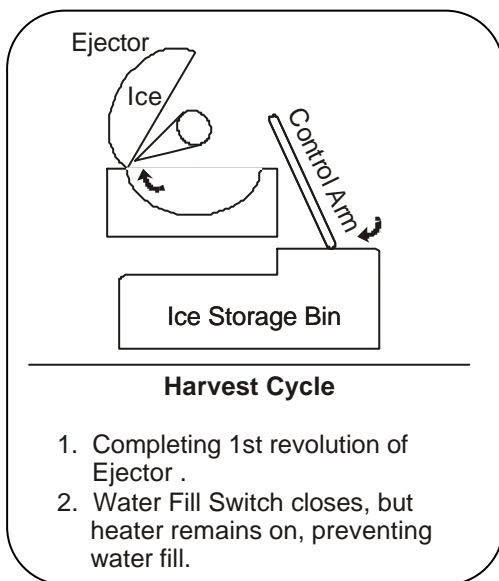

**Step 5**

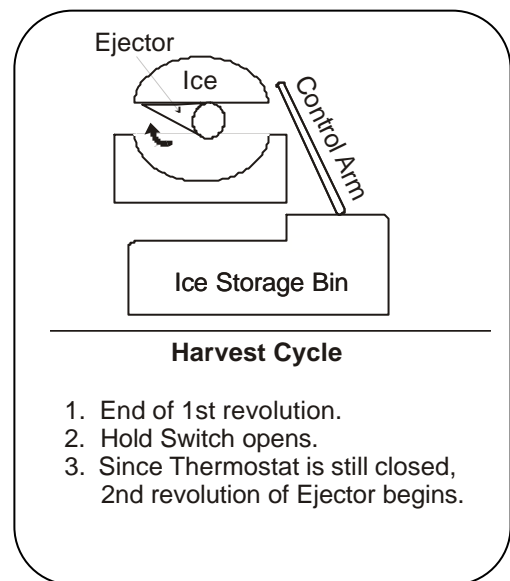

**Step 6**

# 104 Section F - Ice Maker

## Step 7

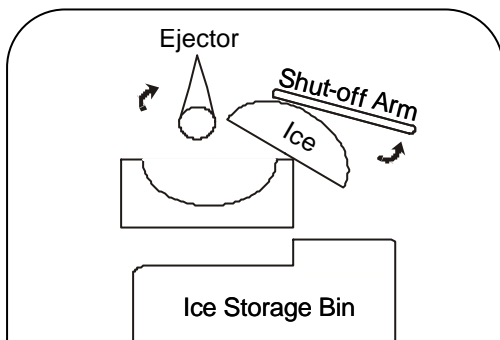

### Harvest Cycle

1. Hold Switch closes.
2. Motor energizes.
3. Mold Heater remains energized.
4. Shut Off Arm raises and lowers.
5. Ice dumps into bin.

## Step 8

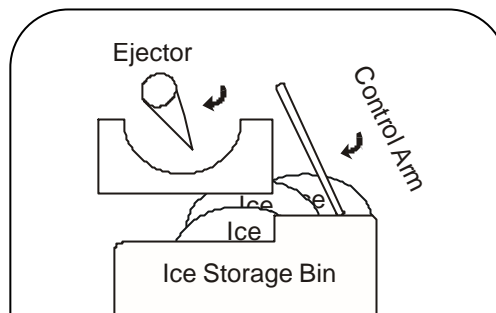

### End of Harvest Cycle

1. During end of 2nd revolution, Mold Heater resets Thermostat.
2. Mold Heater de-energized.
3. If container is full, Control Arm opens Shut Off Switch.

## Step 9

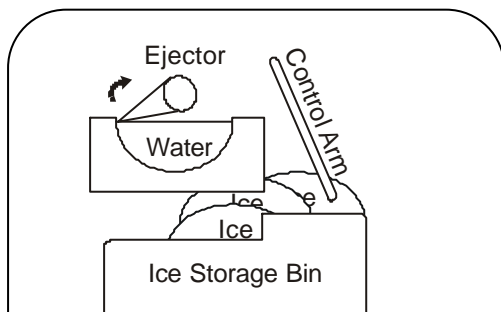

### Fill Cycle

1. Near completion of 2nd revolution of Ejector, Water Fill Switch closes and water fills mold.

## Step 10

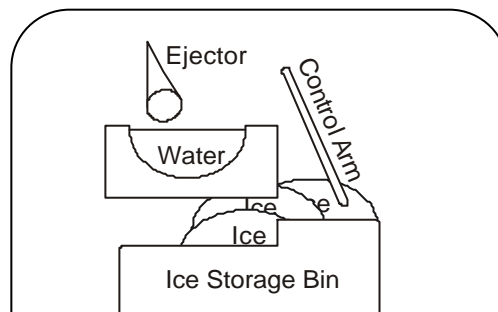

### End of Fill Cycle

1. Hold Switch goes to normally closed position.
2. Water Fill Switch opens.
3. Freeze Cycle begins.





## ICE DISPENSER CONTAINER & RAIL ASSEMBLY

The Ice Dispenser Container slides into the Rail Assembly mounted directly below the Ice Maker. Ice is ejected from the container by an Ice Auger connected to the Solenoid Assembly, and dispensed at the bottom front of the container where it enters through a Gate on the Crusher Housing. The Gate is opened and closed by a Control Rod that fits in the Actuator of the Solenoid Assembly. The ice is then directed into an ice chute mounted on the interior of the freezer door. The Ice Container must be properly placed on the rail assembly to assure proper dispensing. The container should be slid on top of the rails on the Rail Assembly up against the Motor Cover, with the Rotation Stop and Ice Auger protruding through the holes in the back of the Ice Container.

### Dispenser Auger Motor & Solenoid Assembly (Solenoid Assembly not on all models)

The dispenser Auger Motor, Solenoid Assembly, Light Socket and Bulb (40 Watt appliance bulb), and wiring disconnects are mounted on the back on the Rail Assembly Motor Cover. The motor and solenoid mounting screws are located on the front of the Motor Cover.

#### To Remove Auger Motor:

1. Disconnect refrigerator from electrical supply.
2. Remove Ice Cream Shelf and slide Ice Container forward and off Rail Assembly.
3. Loosen 2 screws holding Ice Maker to rail assembly. Unplug Molex connector and lift Ice Maker off of loosened screws and pull free.
4. Remove 2 screws on bottom of Rail Assembly holding it to mounting brackets. Unplug Molex connector. Lift up on Rail Assembly and pull forward, freeing it from mounting brackets.
5. Remove screw securing green ground wire to motor housing on back of Motor Cover. (See Figure G1.)
6. Disconnect two (2) leads hooked to Auger Motor windings (Leads are purple and white - See Figure G1).
7. Rotate Drive Bar and Nut (located on front of Motor Cover) in counterclockwise position until it comes free of Auger Motor shaft. (See Figure 2.)

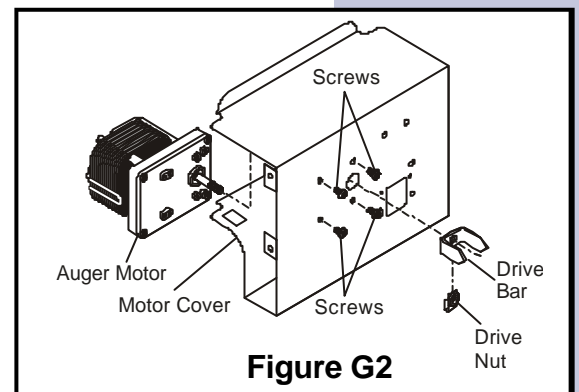
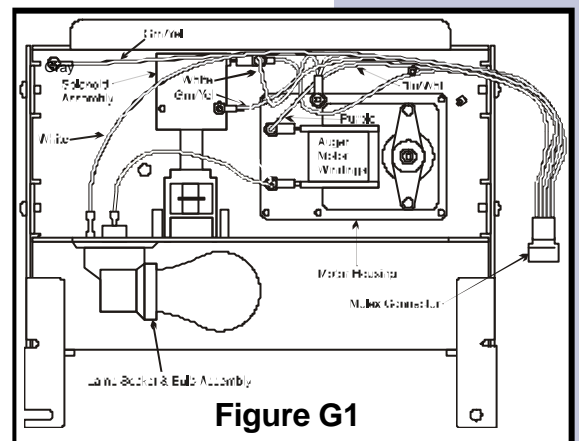

# 108 Section G - Ice & Water Dispenser

8. Remove four (4) motor mounting screws and pull Auger Motor free from Motor Cover.
9. Replace assembly in reverse order.

## To Test Auger Motor:

1. Read ohms value of motor windings using Multimeter on resistance scale. (Put test leads on terminals where purple and white wires were disconnected from Step 6 of procedure "To Remove Auger Motor").
2. Resistance reading should be low ohms. If you get anything else, replace motor.

## To Remove Solenoid Assembly:

1. Disconnect refrigerator from electrical supply.
2. Remove Ice Cream Shelf and slide Ice Container forward and off Rail Assembly.
3. Loosen 2 screws holding Ice Maker to rail assembly. Unplug Molex connector and lift Ice Maker off of loosened screws and pull free.
4. Remove 2 screws on bottom of Rail Assembly holding it to mounting brackets. Unplug Molex connector. Lift up on Rail Assembly and pull forward, freeing it from mounting brackets.
5. Remove 4 screws holding back cover to rail assembly. Remove foam block over solenoid coil.
6. Remove screw securing green ground wire to Solenoid Assembly on the back of Motor Cover. (See Figure G1.)

7. Disconnect two (2) leads hooked to solenoid coil (Leads are blue with a white stripe and white - See Figure G1).
8. Remove four (4) mounting screws on front of Motor Cover and pull Solenoid Assembly free. (See Figure G3.)
9. Replace assembly in reverse order.

## To Test Solenoid Assembly:

1. Read ohms value of solenoid coil using Multimeter on resistance scale. (Put test leads on terminals where blue with white stripe and white wires were disconnected from Step 6 of procedure "To Remove Solenoid Assembly").

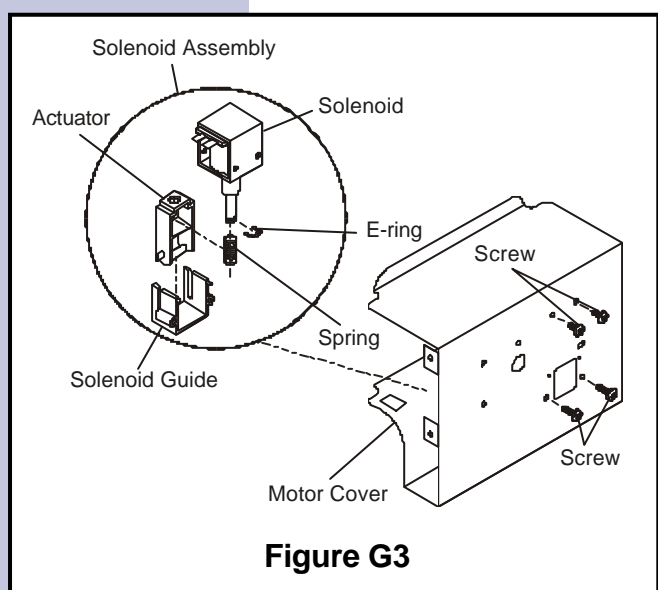

**Figure G3**

## To Remove Lamp Socket and Light Bulb:

1. Disconnect refrigerator from electrical supply.
2. Remove Ice Cream Shelf and slide Ice Container forward and off Rail Assembly.
3. Loosen 2 screws holding Ice Maker to rail assembly. Unplug Molex connector and lift Ice Maker off of loosened screws and pull free.
4. Remove 2 screws on bottom of Rail Assembly holding it to mounting brackets. Unplug Molex connector. Lift up on Rail Assembly and pull forward, freeing it from mounting brackets.
5. Disconnect yellow and white wires connected to lamp socket located behind Motor Cover.
6. Press in on two tabs on bottom of lamp socket base and push through mounting hole. (See Figure G4.)
7. Replace lamp socket in reverse order.

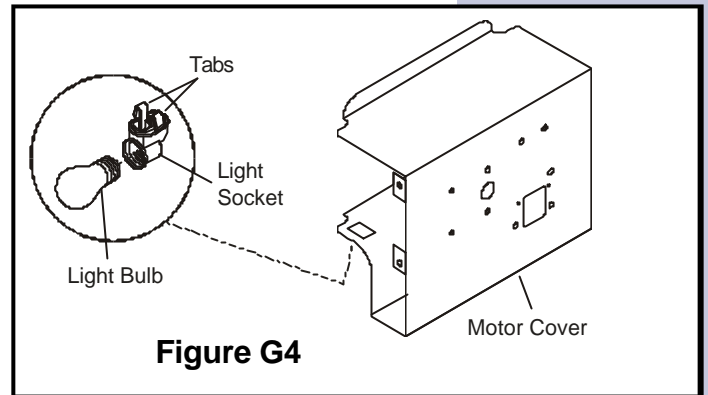

## ICE AUGER & CRUSHER ASSEMBLY

### To remove Ice Auger & Crusher Assembly:

1. Remove four (4) screws holding Ice Container Front to Ice Container.
2. Remove two (2) screws on underside of Ice Container, holding Crusher Housing to container.
3. Remove screw holding Control Rod to container, located on underside of container.
4. Remove three (3) Hex head screws holding Crusher Housing to Front Plate. (See Figure G5)
5. Remove E-ring and washer on front of Crusher Housing. (See Figure G5.)

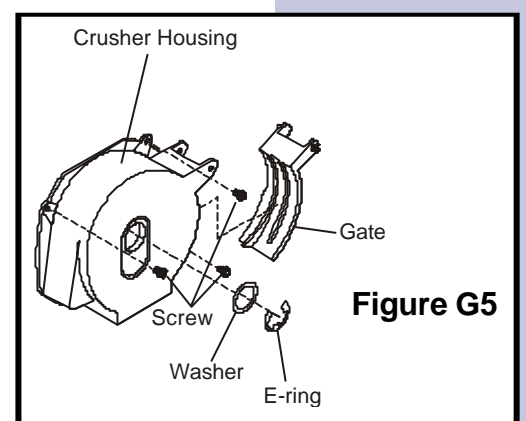

## CAUTION

The Crusher Blades are very sharp. Use protective gloves when handling Crusher Blades.

# 110 Section G - Ice & Water Dispenser

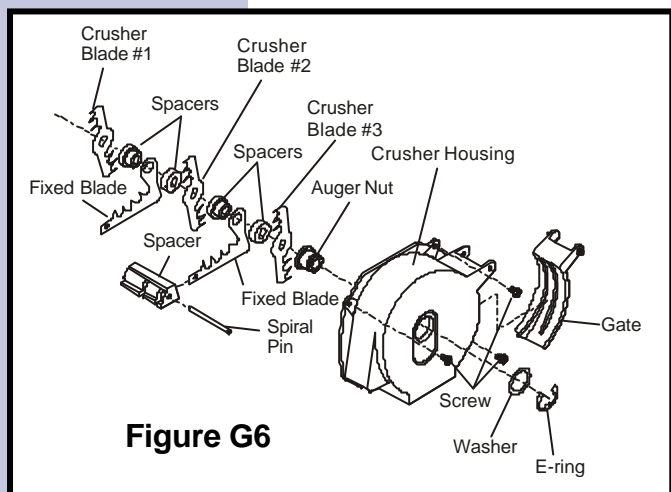

## To replace Crusher Blades:

1. Remove Auger Nut to gain access to Crusher Blades. Each blade is separated by Spacer. (See Figure G6.)
2. Remove Crusher Blades and Spacers until you get to one that needs replacement.
3. Replace assembly in reverse order.

## ICE AND WATER DISPENSER ASSEMBLY

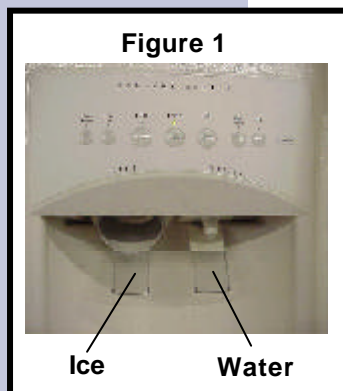

### FEATURE LEVELS

The ice and water dispenser will have two actuators. One for water and a second for ice. (See Figure 1)

There will be different feature lay outs used on the ice and water side by sides.

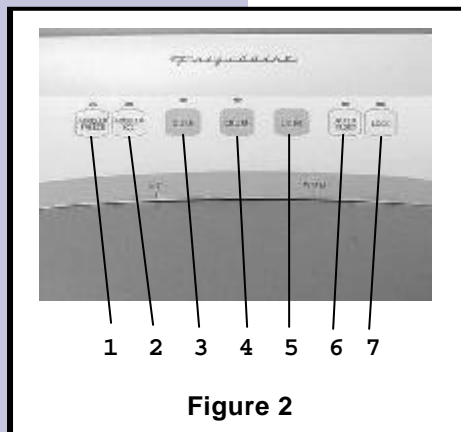

### Seven Selection Dispenser: (See Figure 2.)

1. Extreme Freeze, Press to drop freezer temp to -6 F for a period of 16 hours.
2. Extra Ice, Press to increase ice production for a period of 12 hours.
3. Cube, Press to get cubed ice.
4. Crush, Press to get crushed ice.
5. Light, Press to turn on light in dispenser.
6. Filter RESET, Press and Hold five seconds to reset light. (This light will tell you when to replace the water filter.)
7. Lock, Press to disable dispenser. (Child Lock)

## Icon Model Dispenser: (See Figure 3)

1. Cube, Press to get cubed ice.
2. Crush, Press to get crushed ice.
3. Light, Press to turn on light in dispenser.
4. Filter Status, Press and Hold five seconds to reset light. (This light will tell you when to replace the water filter.)
5. Lock, Press to disable dispenser. (Child Lock)
6. Extreme Freeze, Press to drop freezer temp to -6 F for a period of 16 hours.
7. Extra Ice, Press to increase ice production.

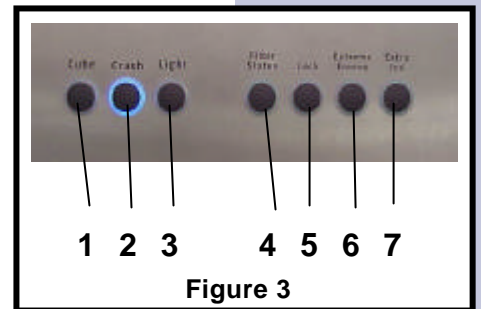

Figure 3

## Six Selection Dispenser: (See Figure 4)

1. Extra Ice, Press to drop freezer temp to -6 F for a period of 16 hours.
2. Cube, Press to get cubed ice.
3. Crush, Press to get crushed ice.
4. Light, Press to turn on light in dispenser.
5. Filter Status, Press and Hold five seconds to reset light. (This light will tell you when to replace the water filter.)
6. Lock, Press to disable dispenser. (Child Lock)

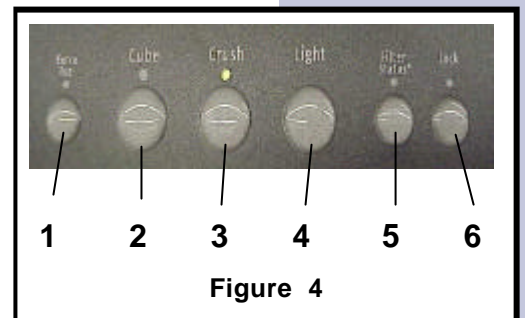

Figure 4

## Electrical Mechanical Dispenser: (See Figure 5)

1. Cube, Press to get cubed ice.
2. Crush, Press to get crushed ice.
3. Light On, Press to turn on light in dispenser.
4. Light Off, Press to turn off light in dispenser.

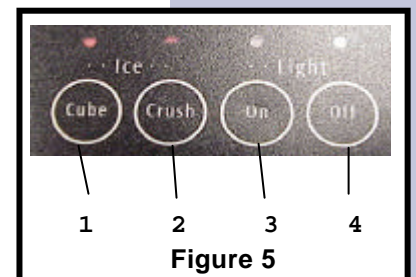

Figure 5

## GAINING ACCESS

To gain access to the control area you will need to pull the drip tray out first. (See Figure 7)

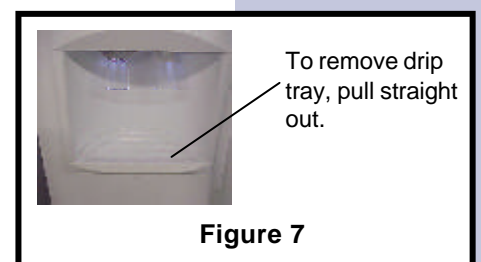
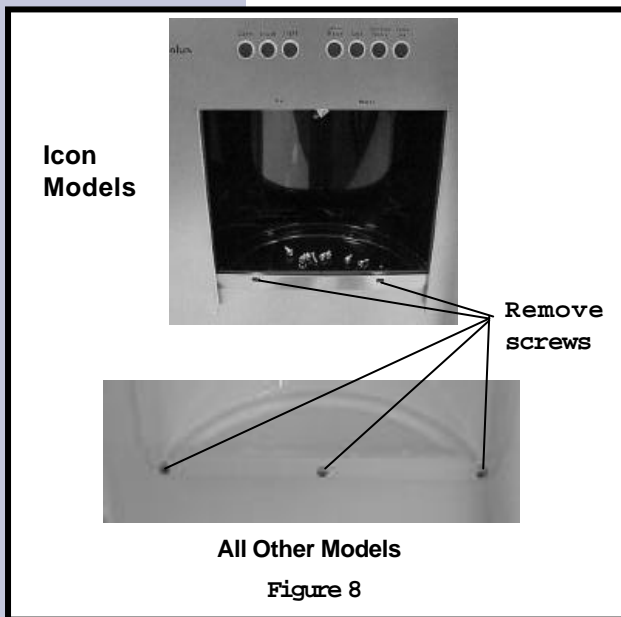

Figure 7

# 112 Section G - Ice & Water Dispenser



With the drip tray removed, remove the 3 screws at the bottom of the front panel, two screws on Icon models. (See Figure 8.)

Lift up on the front panel, there are tabs on the top of the panel that slide into holes in the door panel. On Icon models the tabs are on the sides. (See Figure 9.) Swing panel out to side, being careful not to pull the ribbon connector for the control board.

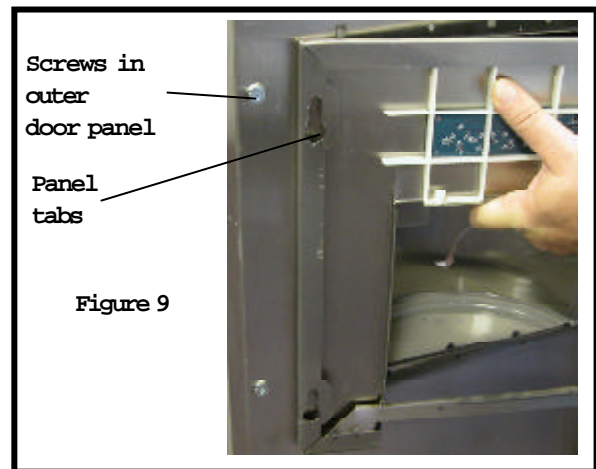

Carefully unplug the ribbon connector from the power board on the dispenser in the door. (See Figure 10) This will give you access to the power board. (See Figure 11)

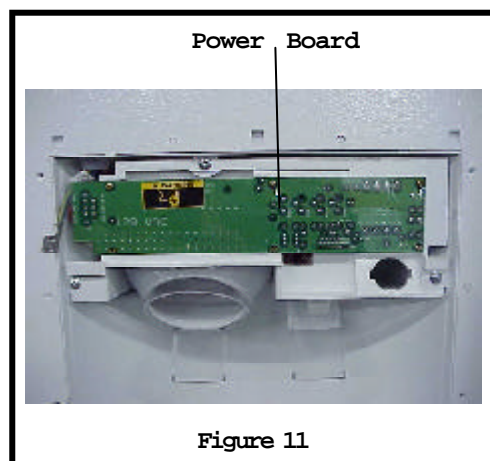
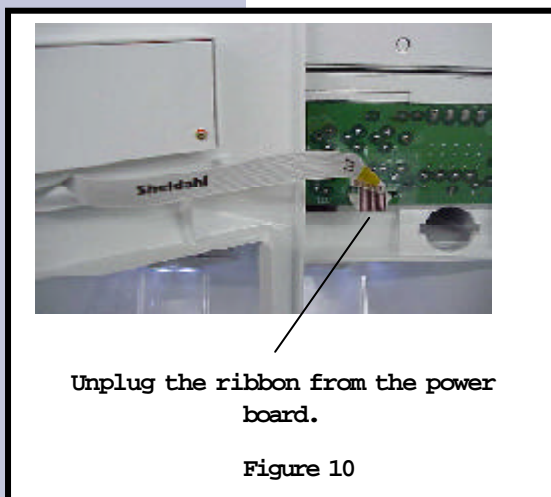

On models with electrical mechanical selector on the front panel, when you remove the front you can gain access to the selector switch (See Figure 12)

The switch is of the push button type (See Figure 13) It will have a red indicator on a slide that will slide up and down to indicate the switch position. The switch will plug directly into the dispenser harness.

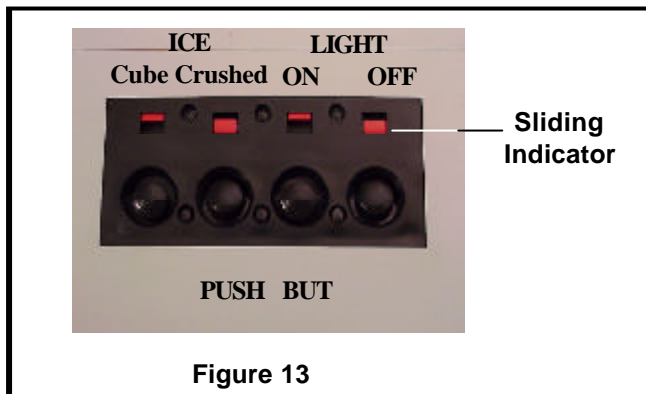

To test the switch you will check between the Red-Black and the Black wire for the dispenser light. Between the Blue-White and the Purple the cube ice solenoid. The switch contacts should show open the off position and closed in the on position for the light. The switch contacts for cube ice should show closed and should show open for crushed position. (See Figure 14)

On models with electronic control to gain access to the control, snap the light socket loose and remove the 6 small screws from the board. (See Figure 15)

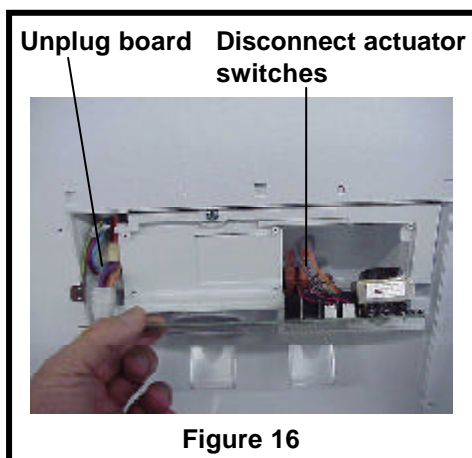

Pull board straight out of housing. Disconnect plug on left side of board. Disconnect 4 wires to dispenser actuator switches. (See Figure 16)

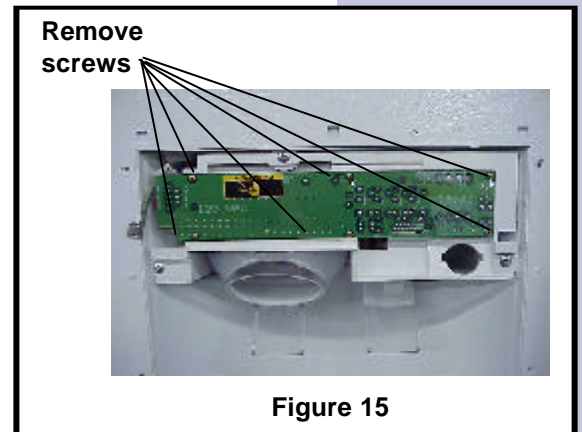
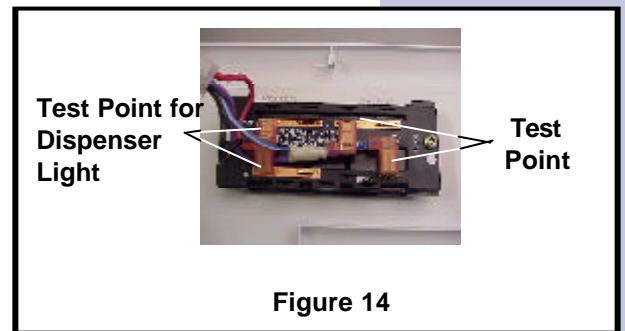
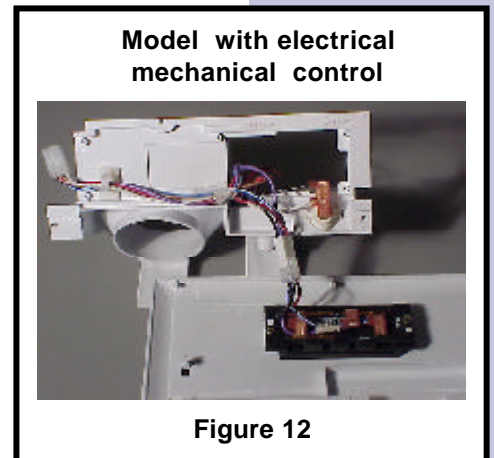

# 114 Section G - Ice & Water Dispenser

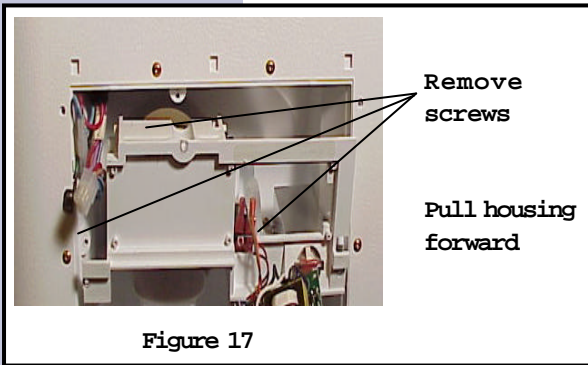

With the board removed, remove the 3 screws from the dispenser housing and pull the dispenser forward. (See Figure 17)

Remove water line from dispenser housing by pulling straight out. (See Figure 18)

With the water line removed, the upper part of the dispenser is free of the freezer door panel. The main housing is part of the door panel, and is not removable. (See Figure 19)

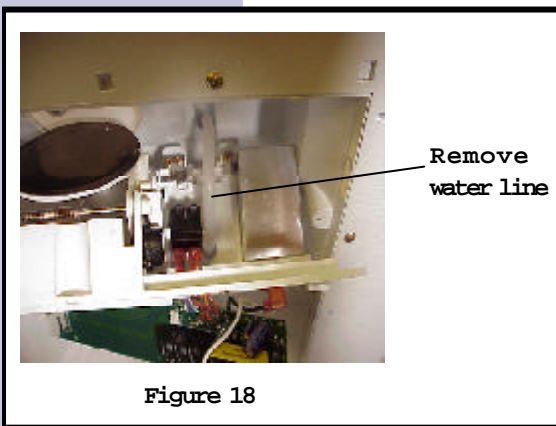

The ice door and actuator switches, as well as the return springs, can be serviced with the control module removed. (See Figure 20)

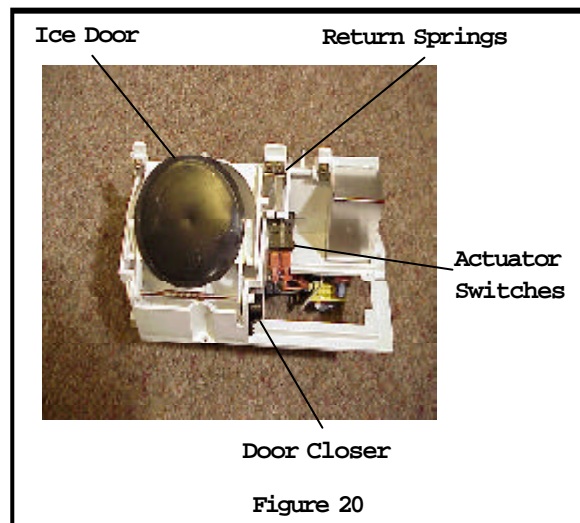
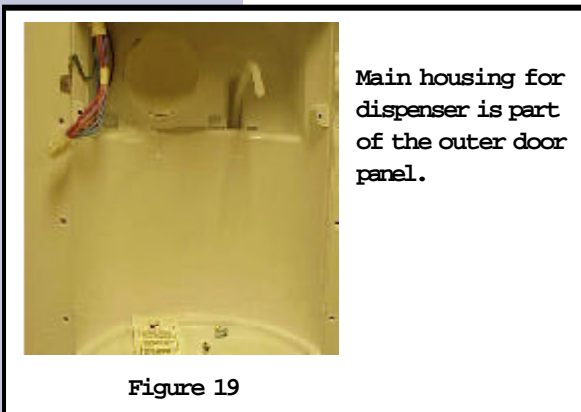

The closer can be replaced by removing 3 screws and lifting closer from housing. The door is held in place with a shaft at the top. The spring that holds the door closed and sealed against the housing is over the shaft and can be replaced by using a small punch and removing the shaft. (See Figure 21)

The door closer is mounted on the side of the housing (See Figure 21) and connected to the door arm with a gear wheel to slow the closing of the door. (See Figure 22) This allows enough time for the ice to clear the chute.

The door will take approximately 20 seconds to close after the glass is removed from the actuator.

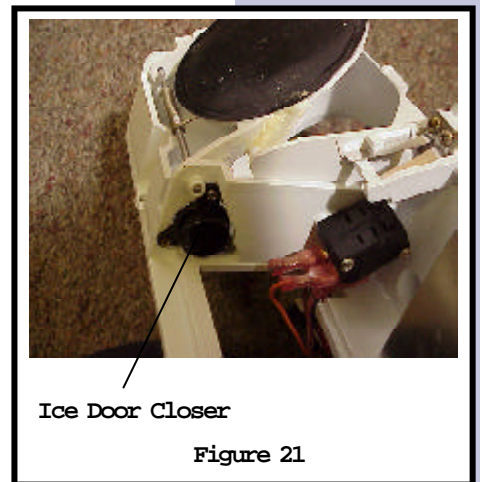
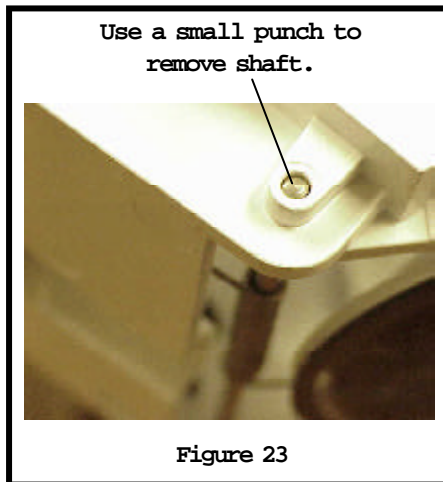

Tension is held against both the water and ice actuator by a stainless steel, two bladed spring mounted behind the actuator switches. The spring is held in place with 2 screws. (See Figure 24)

The Actuators are held in place by stainless clamps at each end of the actuator and the two bladed spring in the middle. (See Figure 25) The actuators can be removed by removing the 4 screws and lifting the paddle / ice chute out of the housing.

On models electrical mechanical switch the dispenser will come apart the same way as models with a control board. The difference is the wiring to the actuator switches and the selector switch are connected directly the plug in the door wiring harness. (See Figure 26)

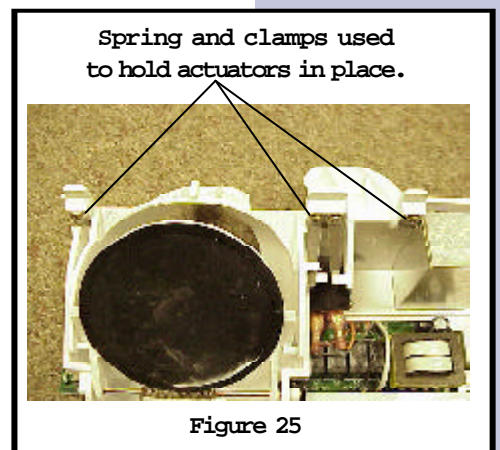
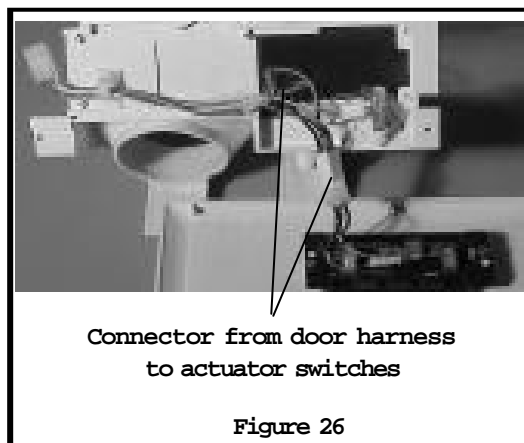
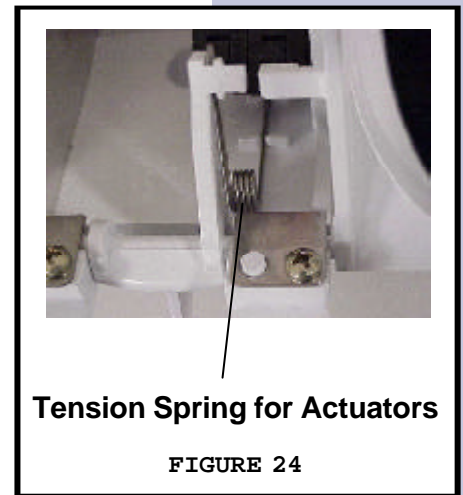

# 116 Section G - Ice & Water Dispenser

Check across the two black wires to test the internal chute heater.



Plug for chute heater

Figure 27

The original heater for the ice chute and housing are foamed in place with the one piece door. It is connected to the door wiring (See Figure 27) harness by a plug coming out of the inner door panel with 2 black wires connected to it. (See Figure 27) If the heater fails, it will be necessary to install an external heater on the housing chute opening in place of the internal heater. The replacement heater will connect to the same plug as the original heater. (See Figure 28)

## Fast Freeze - Fast Ice

When you select the Fast Freeze (Acceler Freeze), the control board sends a signal to the main power supply for a period of 16 hours, to pull the freezer temperature down to -6°F for faster freezing of food.

When you select Fast Ice (Acceler Ice), the control board will send a signal to the main power supply for a 12 hour period to maintain a colder freezer temperature to increase ice production.

Connect wire adaptor to heater and plug into door harness

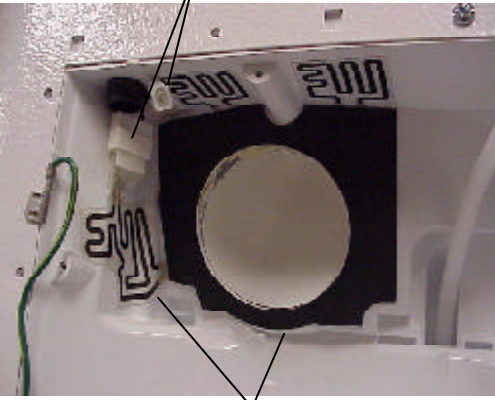

Attach service heater in this location

Figure 28

# Section G - Ice & Water Dispenser

The connector on the left side of the board is for the door wiring harness to plug into. (See Figure 30) This wiring harness connects with the Main Harness through the top freezer door hinge. (See Figure 31) The main harness will connect to the machine compartment harness and to the service cord. The board will then send power to other parts that operate through the board.

The labeling is as follows:

1. NEUTRAL (one side of line to power the board)
2. CUBE (connected to solenoid for ice cubes)
3. AUGER (connected to auger motor)
4. FICE (fast ice/fast freeze feature)
5. WATER (connected to water valve yellow coil)
6. 120 V AC (other side of line to power the board)  
(See Figure 32)

The relays mounted on the board are numbered. (See Figure 33)

- K1 - Controls the Light in the Dispenser.
- K2 - Controls the Water to the Door
- K3 - Controls the Solenoid for Cube Ice
- K4 - Controls the Auger motor

The power supply onto the board is 120 VAC. The transformer is mounted on the board and is used to reduce the operating voltage. (See Figure 32) There are 4 diodes mounted on the board to convert the AC current to DC current. (Touch Board - See Figure 34). The operating voltage for the control board is 8 to 13 V DC.

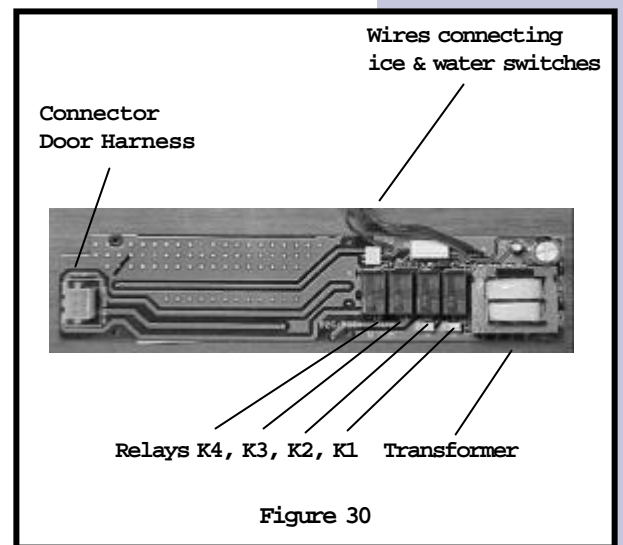

Figure 30

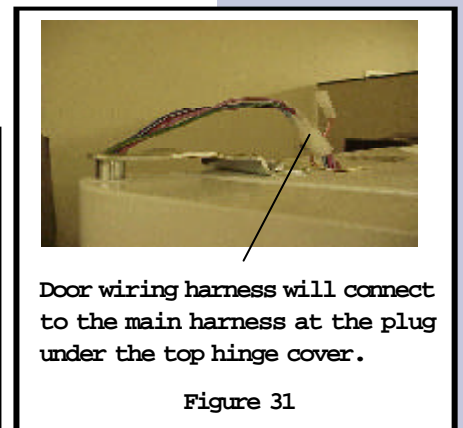

Figure 31

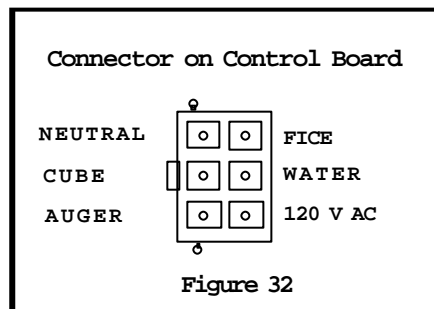

Figure 32

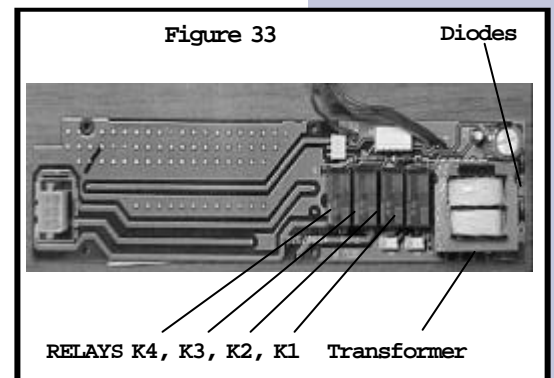

Figure 33

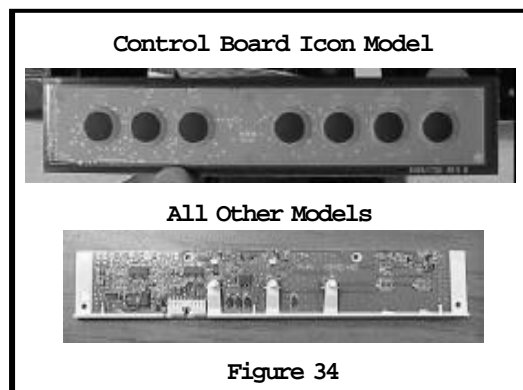
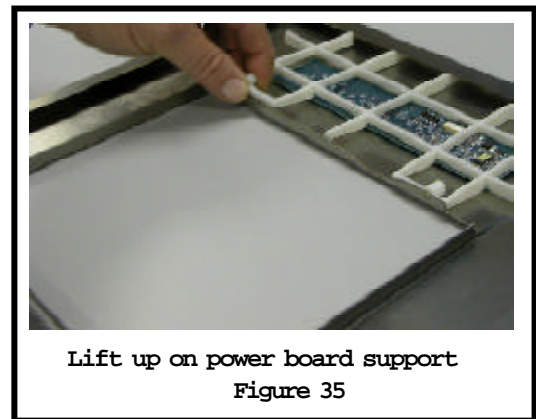
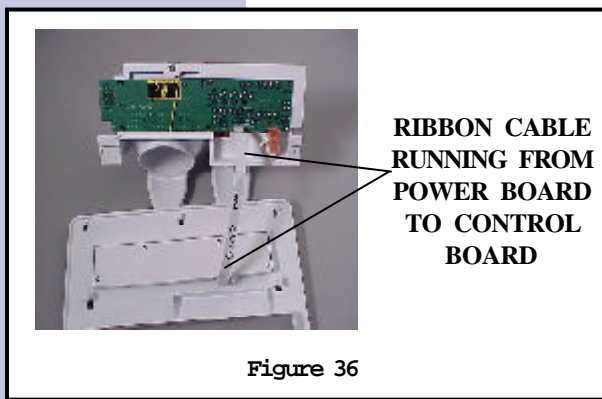

Figure 34

# 118 Section G - Ice & Water Dispenser

The control board is mounted on the front face and can be serviced by removing the front face and removing the 4 screws holding the cover over the board on standard models. On Icon model remove the two screws going from the front face into the bottom of the retainer. Tip the retainer up and pull it out to remove the control board (See Figure 35)

Current will be carried between the power board and the control board by a ribbon connector (See Figure 36). You can check the cable with a Ohm meter one run at a time if you suspect a bad cable.



The ribbon cable will be a replaceable part separate from the power and the control board. To test and/or replace the ribbon, unplug the product and remove the front face plate. Unplug the ribbon from the power board (See figure 36) by pulling straight out. Remove the control board from the front face plate and pull straight down on the lock tab holding the ribbon into the control board. (See Figure 37) Now you can unplug the ribbon from the control board. The ribbon can be tested with a Multimeter using the Ohm setting and test for continuity on each pass of the ribbon. When installing a ribbon into the power or the control board make sure the end of the cable is installed so the contact point on the cable is against the contact points on the board. Also clean the end of the ribbon with a pencil eraser to get a good clean surface for the connection.

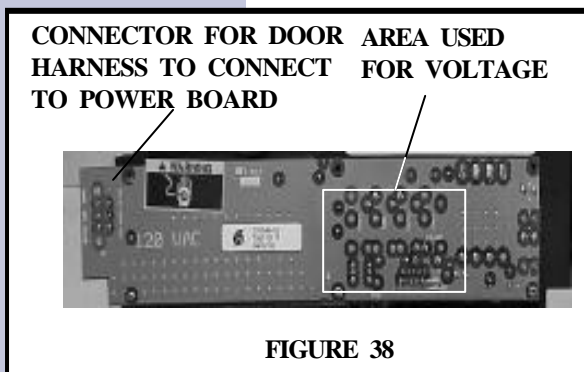
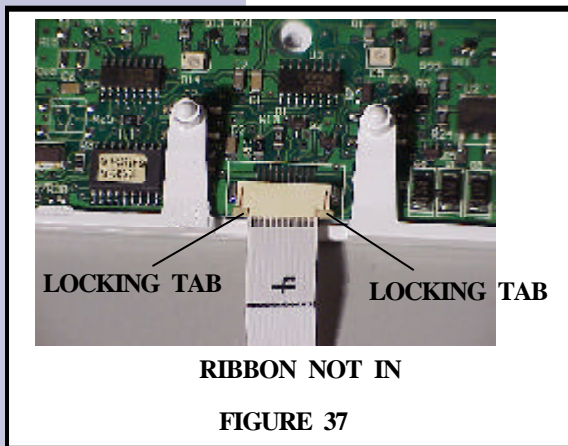

## How To Test The Electronic Dispenser

Labeling was added to the face of the power board to aide the servicer in testing of the control and power board. (See Figure 38)

To test the input voltage from the door harness to the dispenser and the output voltage to the Auger Motor, Solenoid, Water valve and Extra Ice feature if equipped use the connector on the left side of the Power Board shown in figure 39. To Test;

1. Check voltage between 120 VAC and NEUTRAL for input voltage to the dispenser. Should read line voltage.
2. Check between NEUTRAL and CUBE to check the power to operate the cube ice solenoid. Should show 0 voltage until the ice actuator is pushed in, then should show line voltage.
3. Check between NEUTRAL and AUGER to check the power to operate the Auger Motor. Should show 0 voltage until the ice actuator is pushed in, then should show line voltage.
4. Check between NEUTRAL and WATER to check the power to operate the single coil primary water valve and the Yellow coil of the secondary water valve. Should show 0 voltage until the Water Actuator is pushed in, then should show line voltage.
5. Check between NEUTRAL and FICE (Fast Ice Feature if equipped) to check the power to operate the 2 watt 115 V heater on the freezer control cap tube. The board will pulsate the heater so it is on 50 % of the time for a 12 hour period of time. (Should show 0 voltage until the Extra Ice button is pushed, then should show line voltage.)

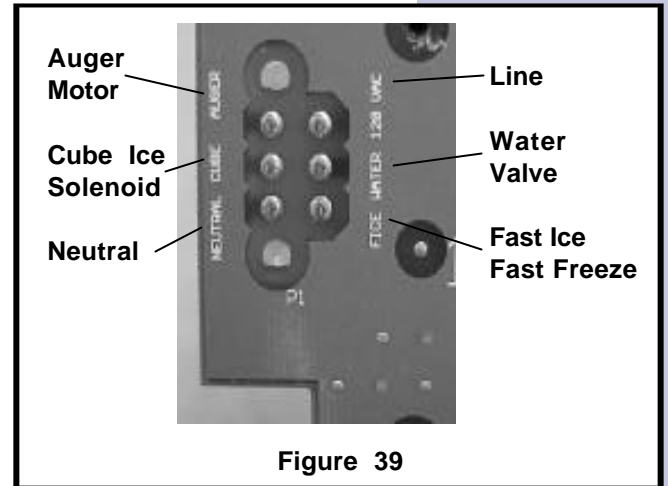

Figure 39

To test the voltage from the power board located in the dispenser to the control board located in the front face plate use the low voltage section of the power board as shown in figure 40. To test:

1. Check voltage between GND and V - IN for input voltage from power board to control board. (Should read 12 VDC + or - 10% voltage.)
2. Check voltage between the two terminals shown in figure 3 under LIGHT for testing power from the control board the relay that operates the dispenser light relay. Should read 0 voltage until the light switch button is pressed or a actuator is pushed in, then you should read 5 VDC + or - 10%.
3. Check voltage between the two terminals shown in figure 3 under WATER for testing power from the control board the relay that operates the water valves. (Should read 0 voltage until the water actuator is pushed in, then you should read 5 VDC + or - 10%.)
4. Check voltage between the two terminals shown in figure 3 under CUBE for testing power from the control board the relay that operates the solenoid. (Should read 0 voltage until the ice actuator is pushed in, then you should read 5 VDC + or - 10%.)

**NOTE**

Dispenser control board must be set for CUBE to operate the cube ice solenoid light relay. Should read 0 voltage until the light switch button is pressed or an actuator is pushed in, then reading should be 5 VDC + or - 10%.

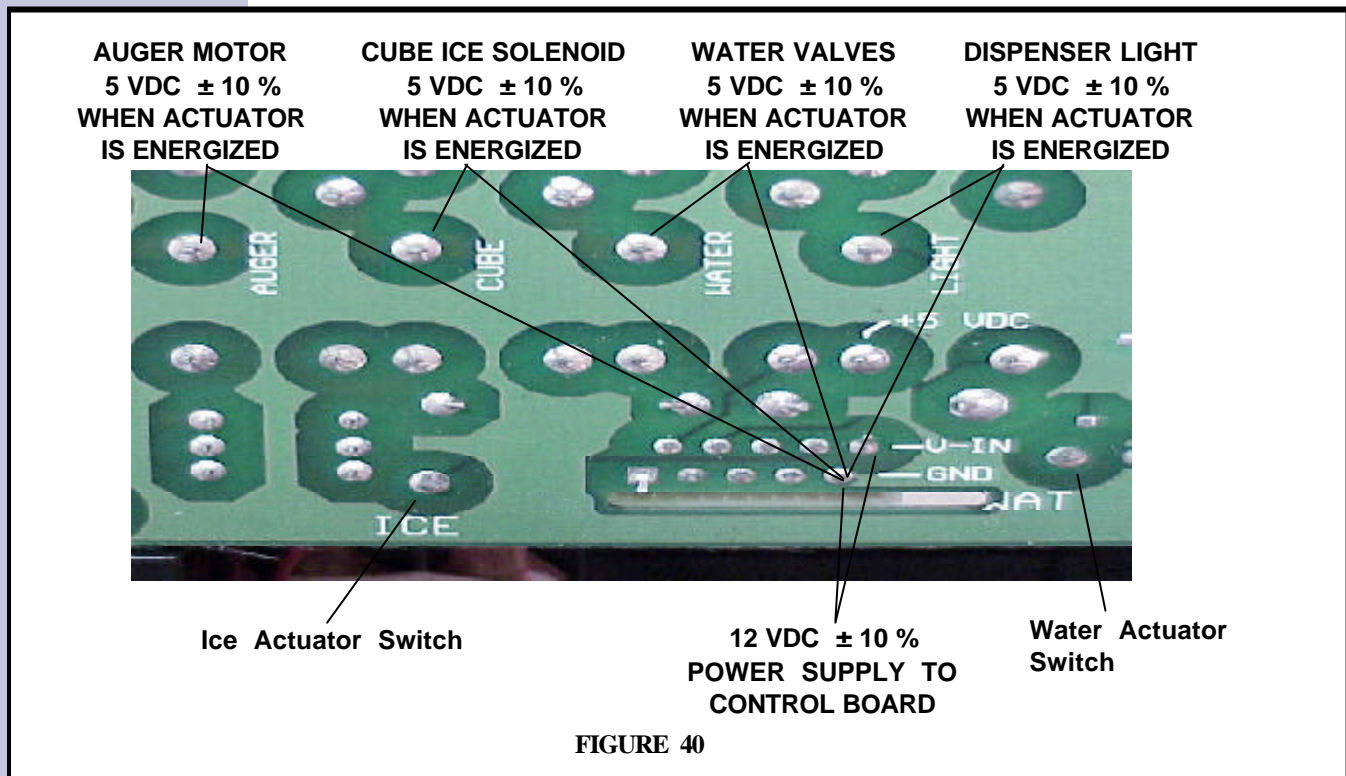

5. Check voltage between the two terminals shown in figure 3 under WATER for testing power from the control board to the relay that operates the water valves. (Should read 0 voltage until the water actuator is pushed in, then you should read 5 VDC ± 10%.)
6. Check voltage between the two terminals shown in figure 3 under CUBE for testing power from the control board to the relay that operates the cube ice solenoid. (Should read 0 voltage until the ice actuator is pushed in, then you should read 5 VDC ± 10%.)
7. Check voltage between the two terminals shown in figure 3 under Auger for testing power from the control board to the relay that operates the auger motor. Should read 0 voltage until the ice actuator is pushed in, then you should read 5 VDC ± 10%.

# Section G - Ice & Water Dispenser

There are lighted paddles in the dispenser on all counter depth models (See Figure 41).

The lights operate off the dispenser power board. (See Figure 42.) If the lights (There are two lights on each paddle.) fail, the paddle needs to be replaced. The paddles mount in the dispenser in the same manner as the non-lighted paddle we have used for the last 3 years. The only difference is there are two small wires coming off the paddle with a plug on the end. This plug will connect to pins on the power board. (See Figure 42 and 43.) This will allow the servicer to replace the paddle with the lights attached. Models with lighted paddles will use a different power board than models with the standard dispenser light off to the side. The difference being, the two identical connection points on the board for the paddle lights. (See figure 43)

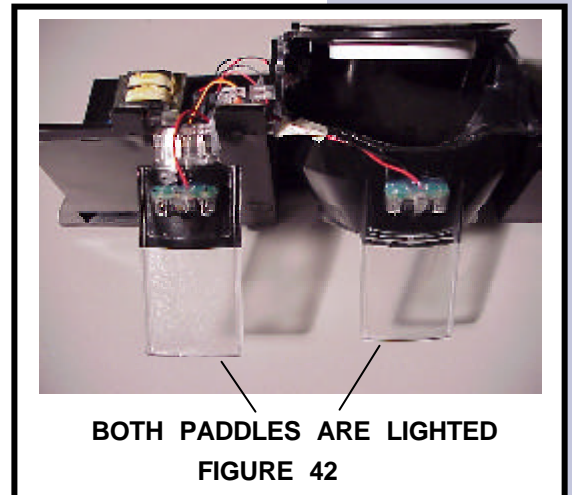
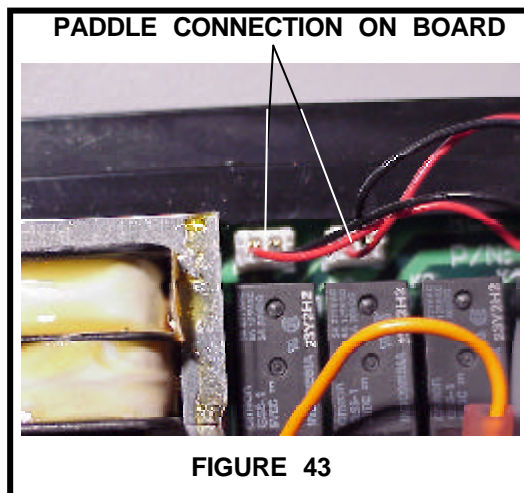
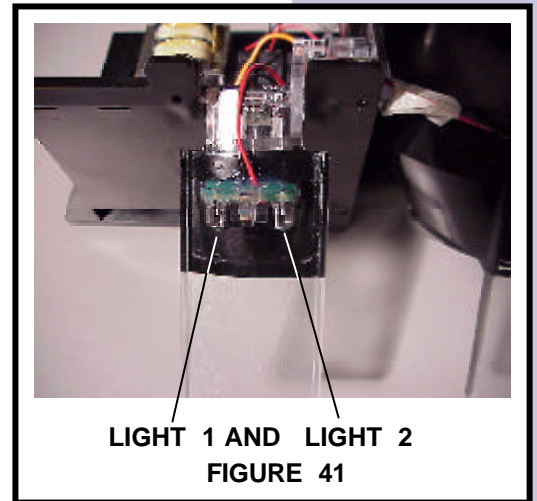

**THIS PAGE IS  
BLANK**

## WATER SYSTEMS

Water for the ice maker and water dispenser is controlled by a dual coil valve and a single coil valve joined together as one. It's mounted just to the right of the condenser on the cabinet. Plastic tubing connects the water valve to the ice maker fill tube, the ice & water dispenser, the water tank (capacity is 30 ounces), and the water filter on all models so equipped.

### Water Valve

Counter Depth models have 1 dual coil valve and 1 single coil valve (see figure H1). The green coil on dual coil valve is for the ice maker and the yellow coil is for the water dispenser. The beige coil on the single coil valve is energized for both water for the ice maker and water for the dispenser. Plastic tubing connects the primary water valve to the filter, water tank and to the secondary valve.

On models with a single coil valve for a primary, you have 2 diodes in the wiring harness connecting the coil of the single coil valve to the 2 coils of the dual coil valve. The diodes are used to prevent current leakage from opening both coils on the dual coil valve everytime the single coil valve is energized.

If a diode is shorted, when the single coil valve opens, current leakage through the shorted diode will cause both coils on the secondary valve to open and you'll have water going into the ice maker and coming out the door at the same time. If the diode fails in the open position, the coil on your secondary valve will open, but the coil on the primary valve will not. As a result, you will not get water to the ice maker or dispenser. Both diodes can be checked with an ohmmeter to see if they are opened or shorted.

The coils on all water valves can be checked with an ohmmeter to see if the coils are opened or shorted. If the coil checks bad, replace the coil. If the coils check good and water pressure is between 20-100 psi, and the valve will not allow water to flow through, replace valve. It is not necessary to replace the whole valve assembly if one coil is bad. The two valves can be separated by inserting a screwdriver at point A in Figure H1.

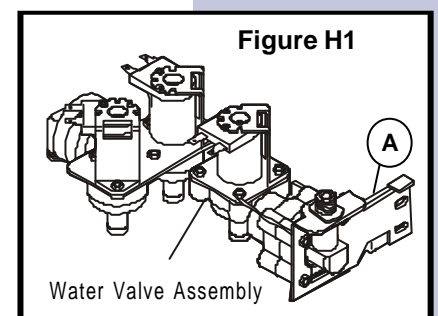

# 124 Section H - Water System

## PureSource Water Filters

Counter Depth models can have either a Front Filter (see Figure H2) or a Rear Filter (see figure H3). The rear water filter must be changed at a minimum of twice a year. But, under certain water conditions such as large concentrations of calcium, alkali, or other particulate matter in the water, a filter may require changing more frequently. A good way to judge whether the filter needs to be replaced is when the water flow to the dispenser starts slowing down and there has been no change to the water pressure to the product. Operating water pressure should be a minimum of 20-100 psi.

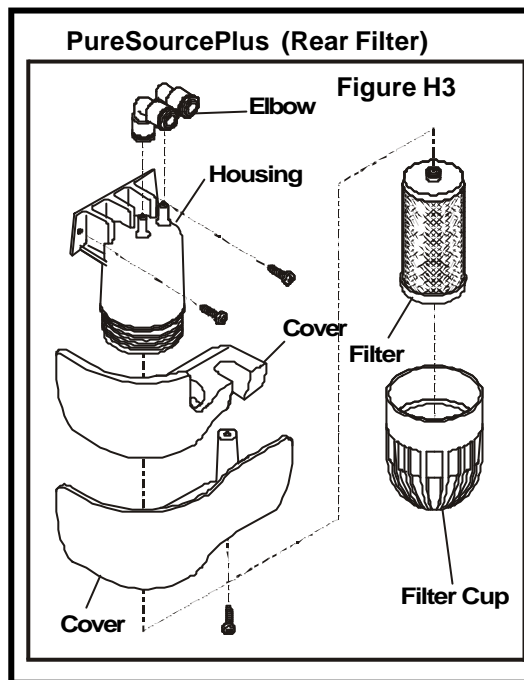
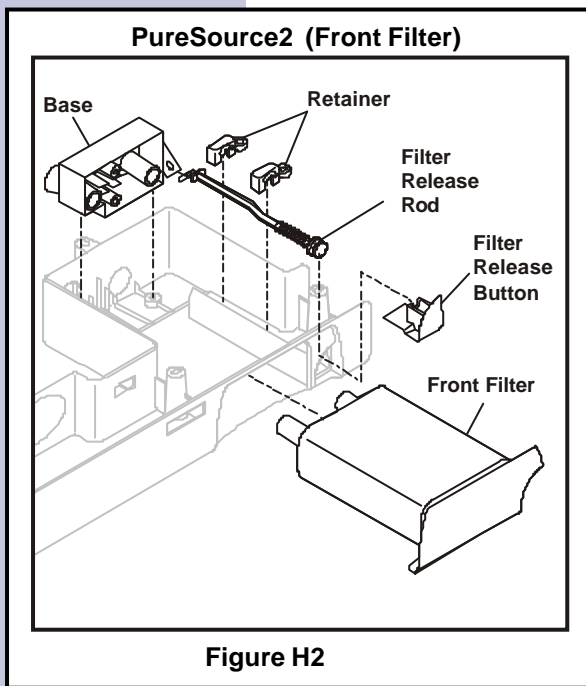

## Water Tanks

Counter Depth refrigerators will have a roll tube tank Assembly as shown in Figure H4.

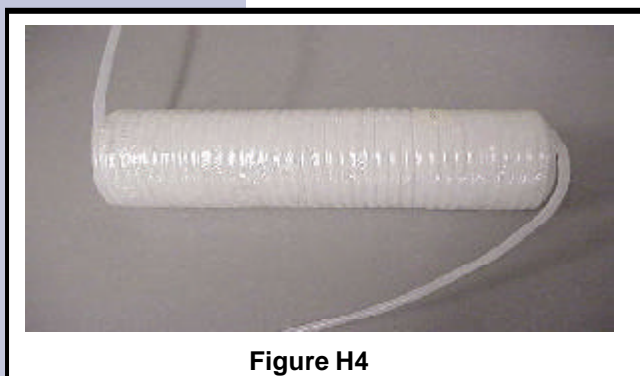

The water line from the primary water valve (single coil valve) goes behind the trim located on the right side of the inside food compartment liner to the water filter. From the water filter the line goes to the water tank, then to the secondary water valve (two coil valve). The two coil valve dispenses water to the ice maker and to the dispenser in the door. By filling the ice maker for the water tank you will get chilled water to the ice maker helping to increase ice production. See Figures H5 and H6 for water system flow diagrams.

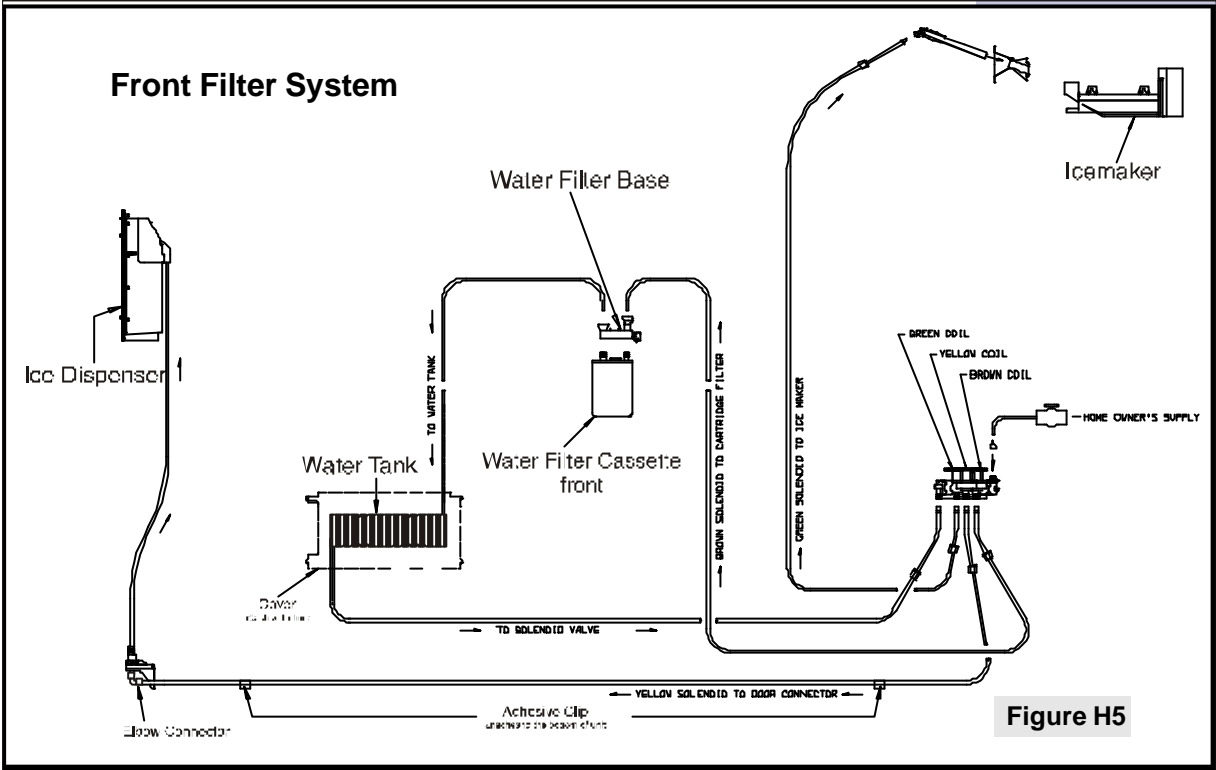

Figure H5

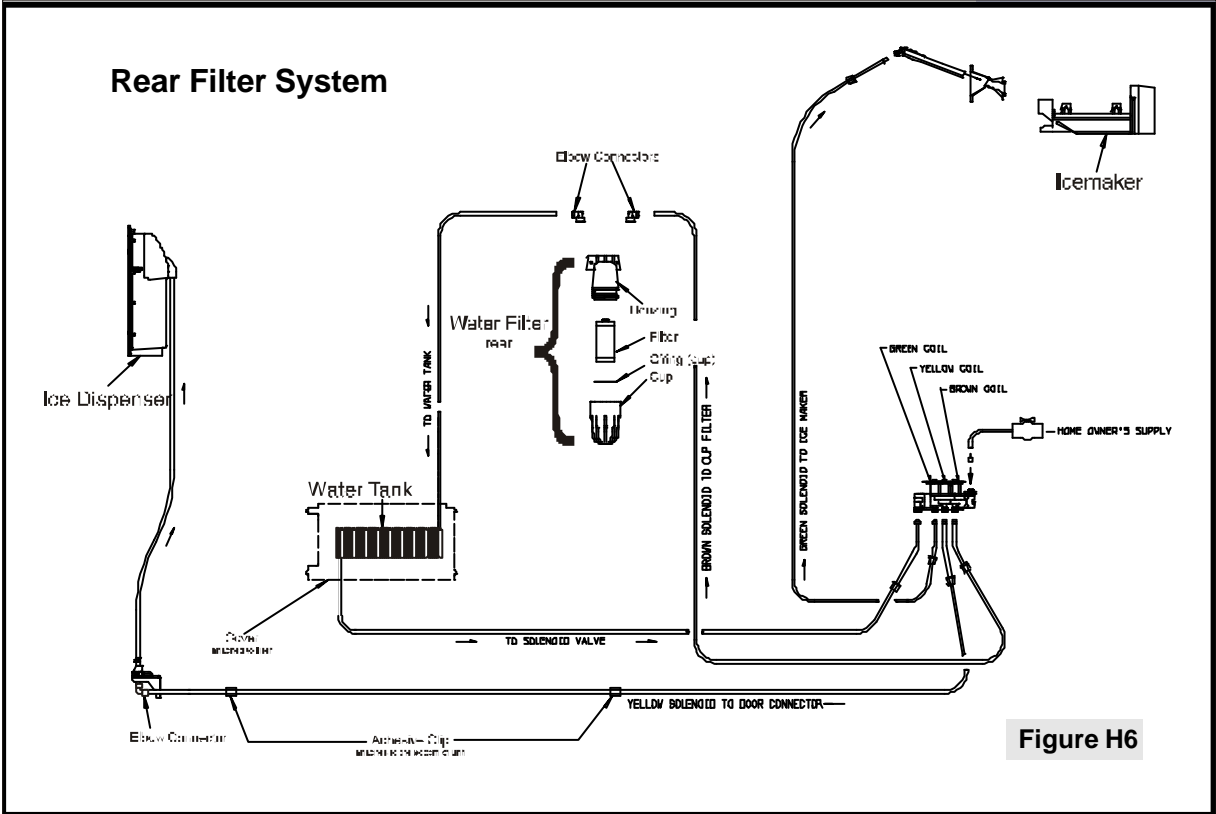

Figure H6

# 126 Section H - Water System

## Diode Replacement Kit 5303918287 For Ice & Water Model Side by Sides With A Water Filter

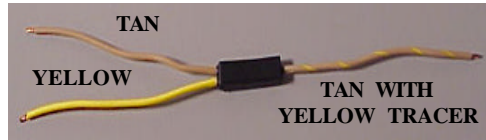
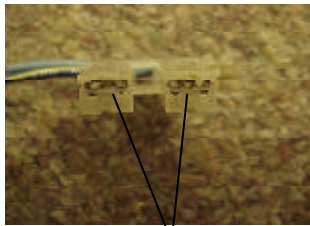
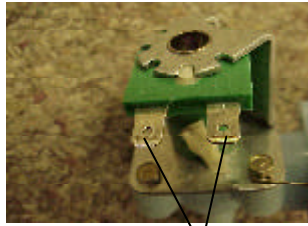

Figure H8



Terminals in



Terminals on

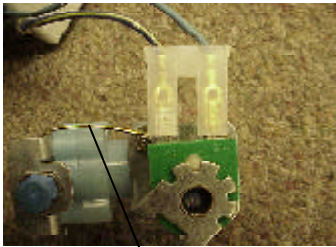

Terminal on Coil is Installed

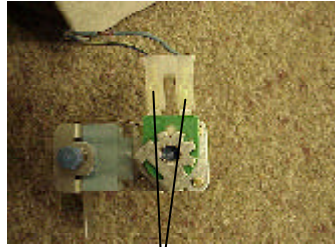

Terminals and Plug

Figure H9

## To Test The Water Fill System

The wiring harness has two diodes in the line between the fill switch on the ice maker and the green coil of the secondary water valve, as well as the water switch or relay on the freezer door and the secondary valve. The diodes are part of the wiring harness. (See figure H8.)

If the diodes fail open, the primary valve will not open for ice and/or water depending on what diode is open. The open diode will not effect the coil on the secondary valve, the secondary valve will open but if the primary valve does not open you will not supply water to the secondary valve.

## Resistance Check

To test the diodes you can use a ohm meter with at least a 10K ohm or higher scale. Take a reading across the diode, reverse your leads and take another reading, the diode should check 10 times higher in one direction than the other.

## Voltage Check for Water to Icemaker

You can also use a volt meter to check the circuit. Connect a volt meter to the water valve coil of the primary valve, and connect a second volt meter to the green coil of the secondary valve. Start Icemaker into a Harvest cycle by holding the Icemaker ON/OFF switch in the ON position until the sweep arm advances to the 2 o'clock position. Then let go of the switch and let the Icemaker advance through a cycle on it's own. A voltage check at the primary valve should yield 42-58 VAC, which is normal and 95-105 volts at the secondary (green coil).

## Digital Meter

If you are using a good meter you will read between 0 and 10 volts with a open diode on the primary valve but you will have over 90 at the secondary.

## Voltage Drop From Heater

In checking the voltage on a ice maker fill you must keep in mind that the coils of the water valves are in series with the heater on the ice maker. The resistance of the heater will cause a drop in voltage. Example, if you have 110 to 120 at the outlet with the product running, between 95 and 105 will be present at the green coil of the secondary valve.

## Voltage Readings Are Different Between Primary And Secondary Valve Coils

If you are getting 10 volts or less at the primary valve but you are getting 95 to 105 at the secondary you have a bad diode. If you are getting 42 to 58 volts at the primary valve and 90 or higher at the secondary this is normal. With the current flowing to the primary valve coil through the diode you are getting 30 cycle instead of 60 cycle current at the coil of the primary valve. Because of this your meter will only read about 1/2 the voltage that is going to the coil.

### No Water at Door

If the ice maker is operating but you can not get water out the door the test and operation of the diode is the same as for the ice maker except for the voltage readings. On the water side you should read the same voltage at the yellow coil of the secondary valve as you have at the outlet. On the primary valve the voltage should read 54 to 78 V AC. If the voltage is below 10 VAC at the primary but good at the secondary, you have a bad diode. If the voltage is low at both the primary and secondary you have a bad connection or a bad power board in the door dispenser.

### Diode Kit

If you have a problem with the diodes, order the diode kit, part number 5303918287. (See Figure H8.) The diodes are part of the wiring harness for the machine compartment.

### Checking Water

If you do your voltage checks and find you have the correct voltage at the coils and the valve are not letting water through, replace the valve. To see which valve is bad, disconnect the water line from the filter to the secondary valve at the inlet of the secondary valve. Place the line in a bucket.

### Ice Maker Valve

Run the ice maker through a fill and see if water will pass through the primary valve and the filter into the bucket. If it does replace the secondary valve. If it does not, remove the primary valve, disconnect the outlet line from the primary valve and run the ice maker through a fill. If still no water, replace the primary valve. If water is coming through, replace the water filter.

### Chilled Water Valve

Place a glass against the actuator and push in to see if water will pass through the valve and the filter into the bucket. If it does, replace the secondary valve. If it does not, remove the primary valve, disconnect the outlet line from the primary valve and place a glass against the actuator and push. If still no water, replace the primary valve. If water is coming through, replace the water filter.

### Low/No Voltage At Coil(s)

One point we need to cover in our testing is good connections at all points in the ice and water wiring. There are a number of connections in the wiring of a refrigerator. On the ice maker, the wiring runs through the plug by the compressor up to the ice maker, back down to the same plug and into the diode harness. On the water dispenser the wiring runs from the plug by the compressor to the plug

---

at the top of the freezer door down to the dispenser and back up through the same plugs to the diode harness. A bad connection at any of the plugs or wire terminals can stop the valves from operating. One of the problems we have found is at the connector on the water valve coils is pushed on with the valve terminal over top the terminal in the plug. (See Figure H9.)

# 130 Section H - Water System

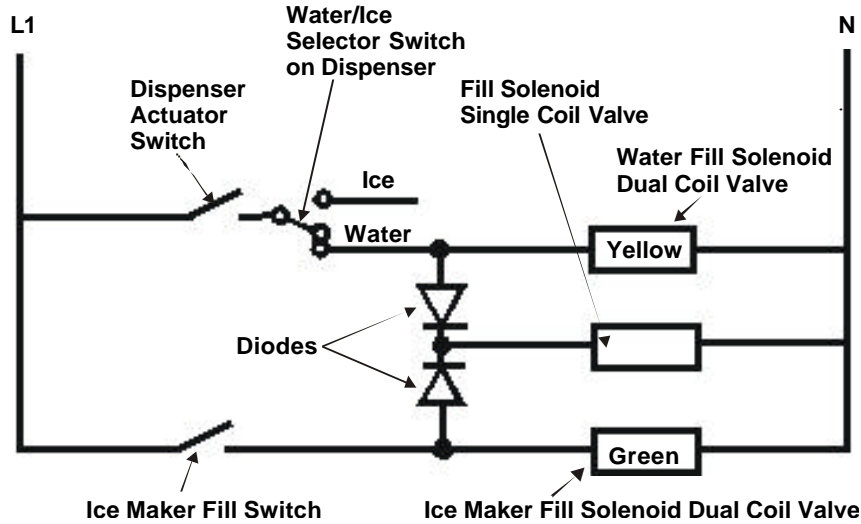

## VOLTAGE READINGS AT GREEN COIL OF SECONDARY VALVE

When Ice Maker is Filling:

Voltage at Outlet	Voltage at Coil	
120 VAC	$100 \pm 10\%$ VAC	Normal (95 to 105 VAC)
100 VAC	$85 \pm 10\%$ VAC	Normal (95 to 105 VAC)
100 - 120 VAC	20 - 76 VAC	Bad connection, Fill Switch, or Heater in Ice Maker.

## VOLTAGE READING AT YELLOW COIL OF SECONDARY VALVE

When Filling A Glass With Water:

Voltage at Outlet	Voltage at Coil	
120 VAC	$119 \pm 10\%$ VAC	Normal
100 VAC	$99 \pm 10\%$ VAC	Normal
100 - 120 VAC	0 - 90 VAC	Bad connection or bad Fill Switch

## VOLTAGE READING AT COIL OF PRIMARY VALVE

When Ice Maker is filling:

Voltage at Outlet	Voltage at Coil	
120 VAC	$50 \pm 10\%$ VAC	Normal
100 VAC	$48 \pm 10\%$ VAC	Normal
100 - 120 VAC	10 - 43 VAC	Bad connection, Fill Switch, or Heater in Ice Maker
100 - 120 VAC	Less than 10 VAC	Open Diode (if current is normal at secondary coil)

**NOTE:** You must remember that with the current flowing to the Primary Valve Coil through the Diode, you are getting 30 cycle instead of 60 cycle current at the coil of the Primary Valve. Because of this, your volt meter will only read about 1/2 the voltage that is going to the coil. The change in the cycle of current does not effect the efficiency of an electromagnetic coil.

Figure H10