

The Hisense logo is displayed in a bold, white, sans-serif font against a dark grey background. The background of the entire page features a dark grey area on the left that transitions into a white area on the right, with three curved, overlapping grey bands separating the two sections.

Hisense

Refrigerator

Service Manual

Model: RC-70 WS4S (BCD-535 W)

1.Warnings and precautions for safety	2
2.Appearance and structure	
2.1 View of the appliance	3
2.2 Wind channel structure.....	4
2.3 Evaporator structure	6
2.4 Compressor room structure	7
3.Basic parameters	8
4.Operation and functions	
4.1 Display controls.....	9
4.2 Defrost mode	13
4.3 Compulsory defrost mode	17
4.4 Error display.....	19
5.Troubleshooting	
5.1 Common problem and checking.....	25
5.2 Faulty start	28
5.3 Refrigeration failure	29
5.4 Thick frost in freezer compartment	32
5.5 Dew in refrigerator compartment	33
5.6 Low temperature of vegetable vase	34
5.7 Breaking of light.....	35
5.8 Noise	36
6.Circuit and checking	
6.1 Circuit diagram	40
6.2 Mainboard	41
6.3 Compressor.....	42
6.4 Fan motor.....	44
6.5 Damper	46
6.6 Light	48
6.7 Door switch	50
6.8 Temperature fuse	51
6.9 Defrost heater	53
6.9 Ice maker	55
7.Cooling system repairing	
7.1 Refrigeration system	61
7.2 Summary of repair	63
7.3 Regulation of repair	64
7.4 Practical work of repair	65
7.5 Brazing reference drawing	67

1 Warning and precautions for safety

Please observe the following safety precautions in order to use safely and correctly the refrigerator and to prevent accident and danger during repair.

1. Be care of an electric shock. Disconnect power cord from wall outlet and wait for more than three minutes before replacing PCB parts. Shut off the power whenever replacing and repairing electric components.
2. When connecting power cord, please wait for more than five minutes after power cord was disconnected from the wall outlet.
3. Please check if the power plug is pressed down by the refrigerator against the wall. If the power plug was damaged, it may cause fire or electric shock.
4. If the wall outlet is over loaded, it may cause fire. Please use its own individual electrical outlet for the refrigerator.
5. Please make sure the outlet is properly earthed, particularly in wet or damp area.
6. Use standard electrical components when replacing them.
7. Make sure the hook is correctly engaged. Remove dust and foreign materials from the housing and connecting parts.
8. Do not fray, damage, machine, heavily bend, pull out or twist the power cord.
9. Please check the evidence of moisture intrusion in the electrical components. Replace the parts or mask it with insulation tapes if moisture intrusion was confirmed.
10. Do not touch the ice maker with hands or tools to confirm the operation of geared motor.
11. Do not let the customers repair, disassemble and reconstruct the refrigerator for themselves. It may cause accident, electric shock, or fire.
12. Do not store flammable materials such as ether, benzene, alcohol, chemicals, gas, or medicine in the refrigerator.
13. Do not put flower vase, cup, cosmetics, chemicals, etc., or container with full of water on the top of the refrigerator.
14. Do not put glass bottles with full of water into the freezer. The contents shall freeze and break the glass bottles.
15. When you scrap the refrigerator, please disconnect the door gasket first and scrap it

2 Appearance and structure

2.1 View of the appliance



- ① Freezer zone LED light
- ② Ice-Maker Front Cover Assembly
- ③ Ice Bucket Assembly
- ④ Wind channel cover in freezer
- ⑤ Freezer shelf
- ⑥ Freezer door Rack
- ⑦ Freezer upper drawer
- ⑧ Freezer lower drawer
- ⑨ Left adjustable bottom feet

- ⑩ Fridge zone LED light
- ⑪ Adjustable odor equipment
- ⑫ Fridge door Rack
- ⑬ Wind channel cover in fridge
- ⑭ Fridge shelf
- ⑮ Bottle Rack
- ⑯ Fridge upper drawer
- ⑰ Fridge lower drawer
- ⑱ Right adjustable bottom feet

Note: Due to unceasing modification of our products, your refrigerator may be slightly different from this Services Manual, but its functions and using methods remain the same.

2.2 Wind channel structure

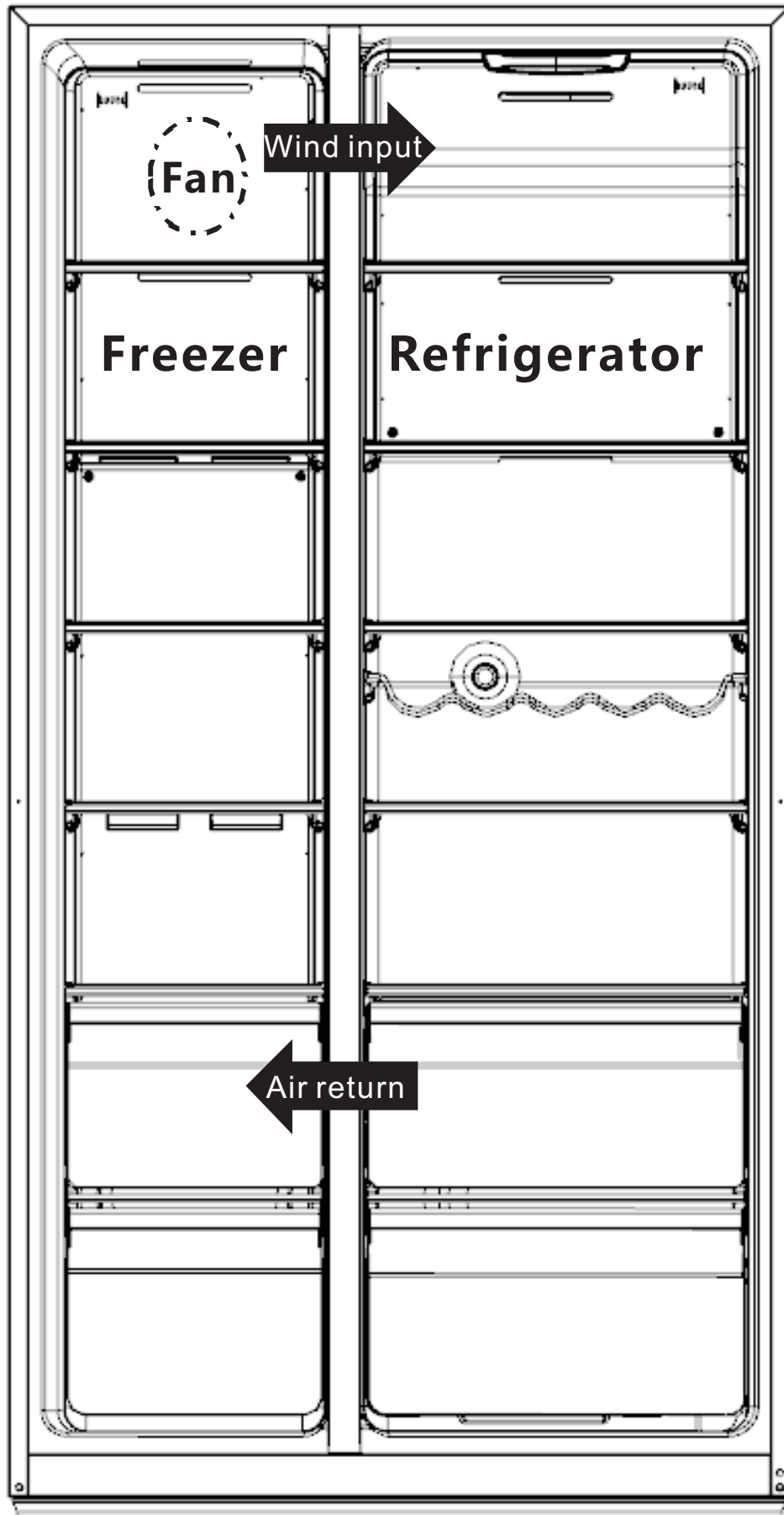

2.2 Wind channel structure

Freezer

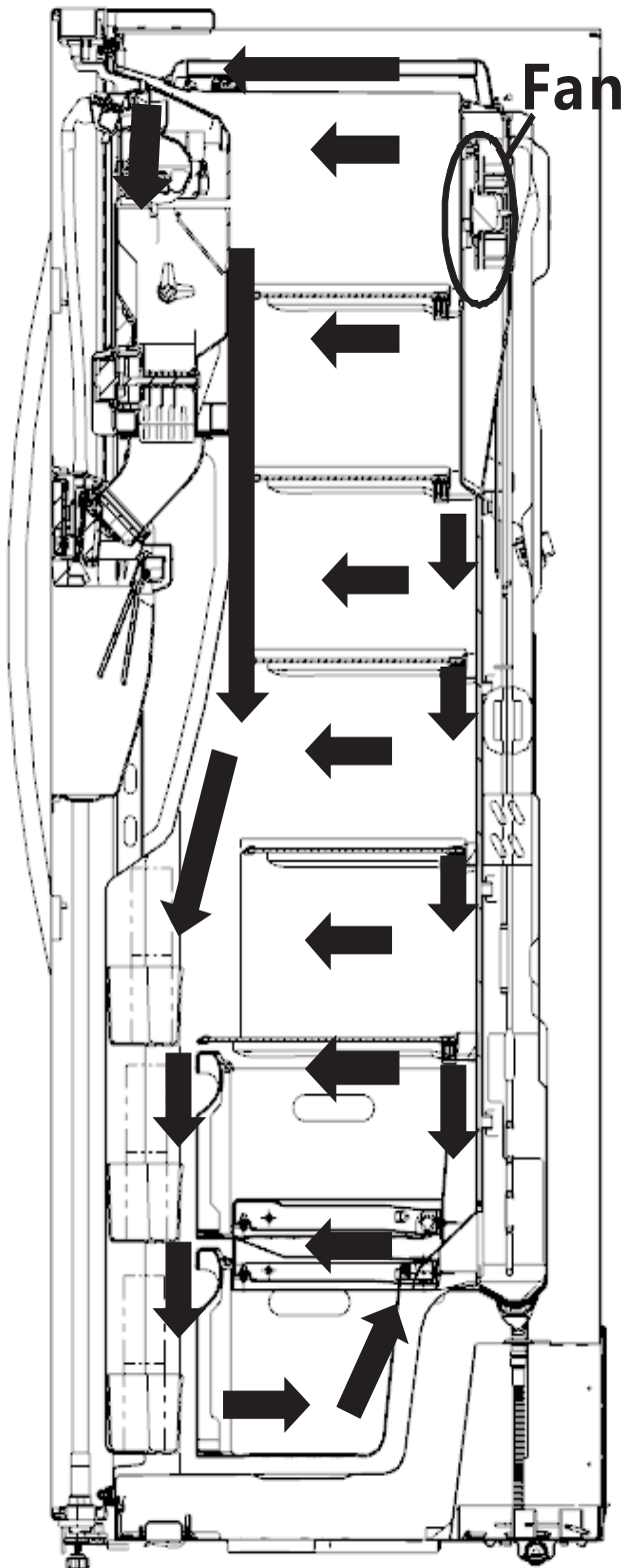

Refrigerator

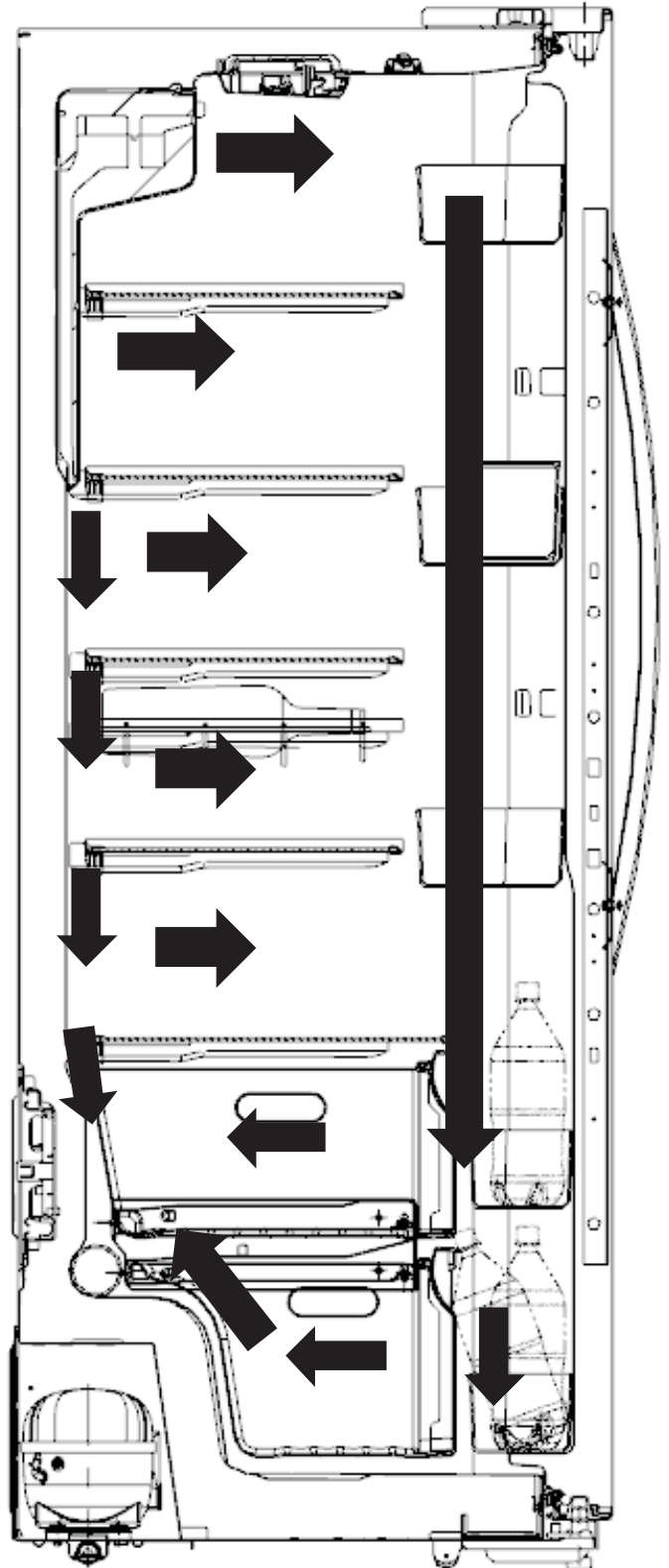

2.2 Evaporator structure

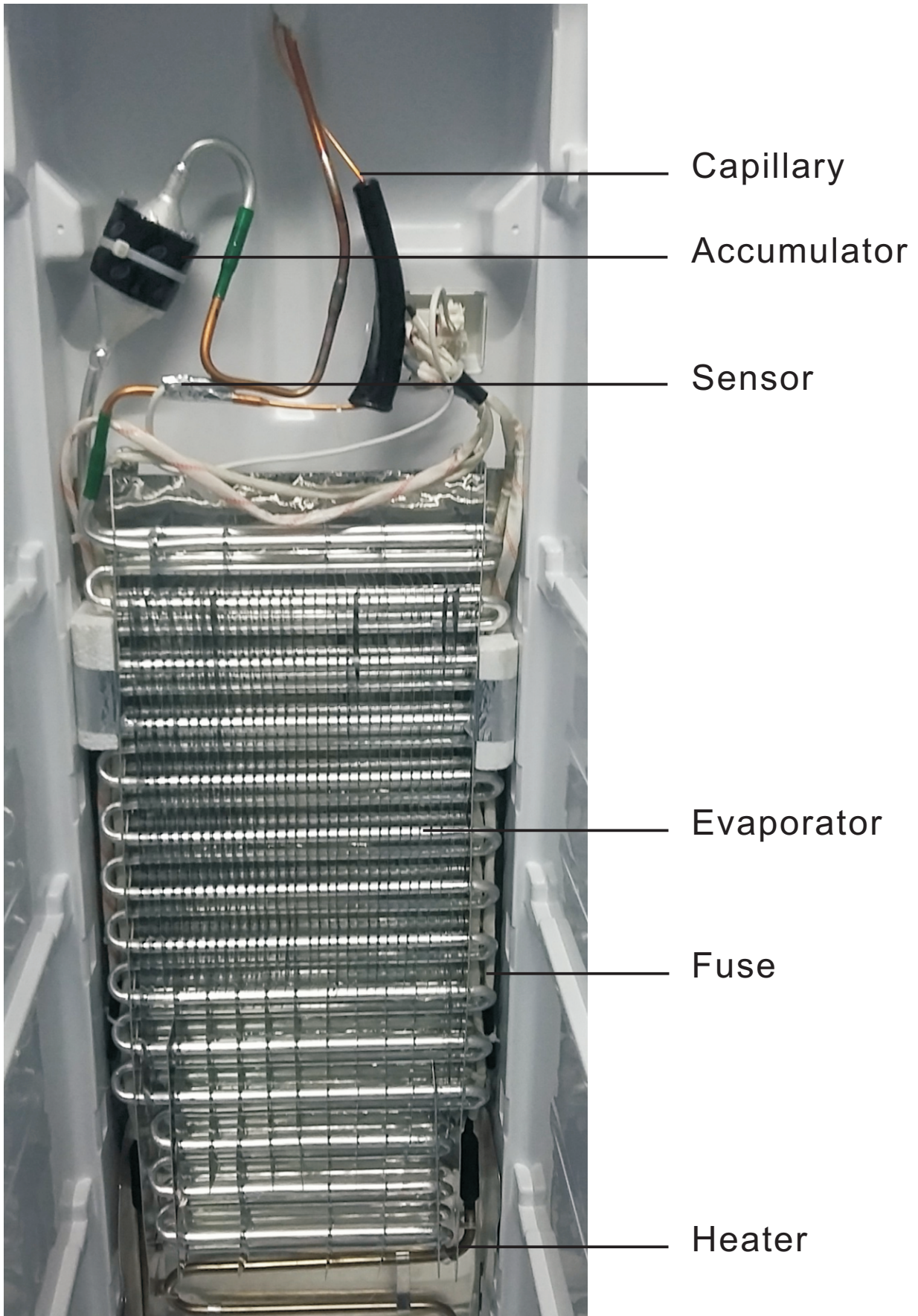

2.2 Compressor room structure

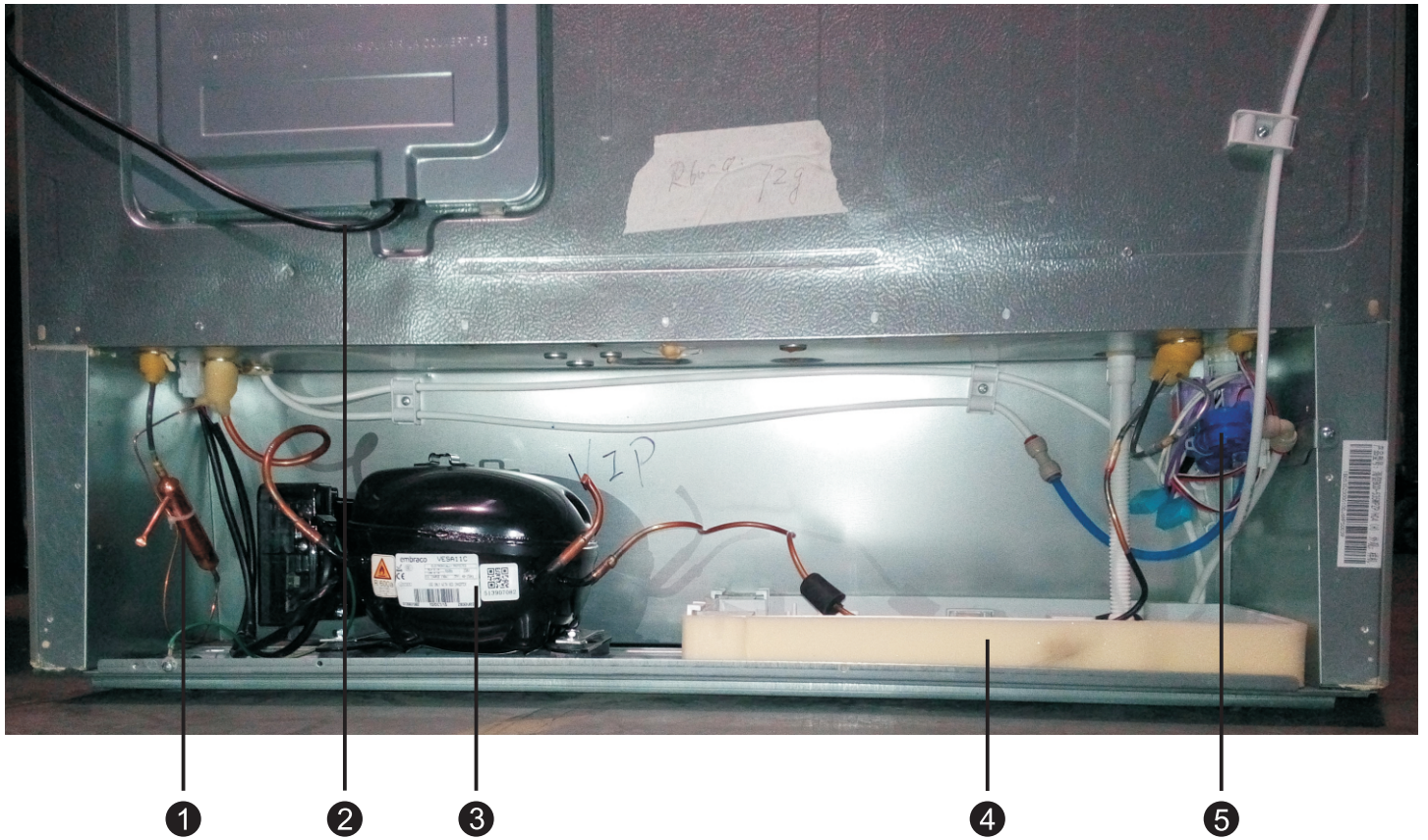

- ① Dry filter
- ② Power cord
- ③ Compressor
- ④ Evaporation dish
- ⑤ Water valve

3 Basic parameters

Content	Unit	Value
Voltage / frequency	V/Hz	220-240/50
Rated current	A	1.6
Rated input power	W	230
Defrost power	W	252
Net capacity	L	535
Net capacity fridge compartment (Fridge/Chill)	L	367
Net capacity freezer compartment	L	168
Energy efficiency class		A+
Climate class (SN=10~32°C, N=16~32°C, ST=16~38°C, T=16~43°C)		SN、N、ST、T
Refrigerator room temperature	°C	2~8
Freezer room temperature	°C	-24~-14
Freezer compartment star rating		160L 4 Star 8L 2 Star
Energy consumption / year	kWh/year	438
Freezing capacity / 24 hours	kg/24 h	13
Max noise level	dB(A)	=42
Kind of coolant / Charge (R134a/R600a) / grammes	R / g	R600a/72

4 Operation and functions

4.1 Display controls

Use your appliance according to the following control regulations, your appliance has the corresponding functions and modes as the control panels showed in the pictures below.

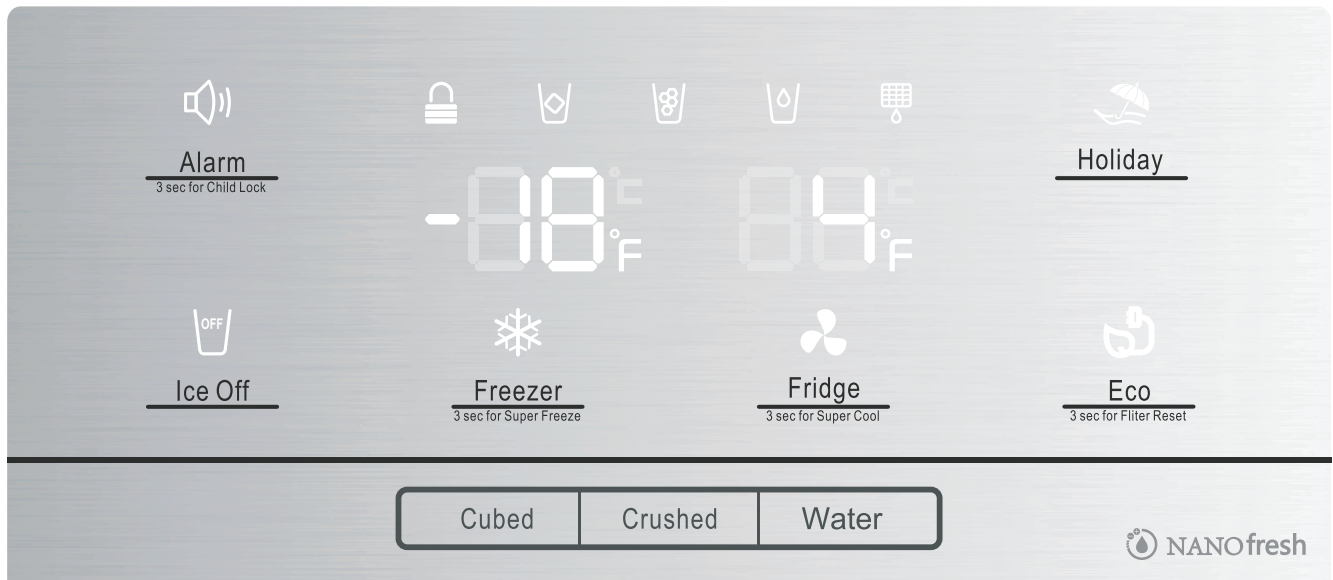

When the appliance is powered on for the first time, the backlighting of the icons on the display panel starts working. If no buttons have been touched and the doors are closed, the backlighting will turn off after 60 seconds.

The control panel consists of two areas about temperature, one area about different modes.

Caution! When you set a temperature, you set an average temperature for the whole refrigerator cabinet. Temperatures inside each compartment may vary from the temperatures displayed on the panel, depending on how much food you store and where you place it. High or low room temperature may also affect the actual temperature inside the appliance.



Alarm

3 sec for Child Lock

“Child Lock and Door Alarm”

This button serves two purposes:



1.Child Lock

Touch and hold “Alarm” for 3 seconds to lock the all the Control Panel including dispenser control panel.

If Control panel is lock, the “” will be shined, and none of the buttons on the Control panel work.

To unlock the Control panel, please touch and hold “Alarm” for 3 seconds again.

2.Door Alarm

In case of alarm, “” icon will be on and will be buzzing sound. Touch “Alarm” key to clear alarm then the “” icon will turn off and stop buzzing.

When door of fridge or freezer is open over 2 minutes, door alarm will come on. In case of alarm, “” icon will be on and will be buzzing sound.

Buzzer will sound 3 times per minute and stop alarm 10 minutes later. Also it will be stoped by closing the door.

When Child Lock is off, you can turn alarm off by touching “Alarm” when doors opening.



To save energy, please avoid keeping doors open for along time when using refrigerator.



Ice Off

“Ice Control”

This button controls the ice maker.

You can touch “Ice Off” icon to control the ice maker. When Child Lock is off, if the ice function is on, you can touch the “Ice Off” icon, the “” will be shined, and ice maker is locked. If you want to unlock ice maker, please touch the “Ice Off” icon again, and the “” will be off.



Holiday

“Holiday and temp. units switch”

This button serves two purposes:

1.Holiday

If you are going to be away for a long period of time such as a long holiday or business trip, you can activate this function by touching “Holiday” icon, and “” will be illuminated.

When the holiday function is activated, the temperature of the fridge is automatically switched to 15°C and the freezer to -18°C to minimize the energy consumption.

The fridge temperature seting displays “—” and the freezer compartment remains on.

When the holiday function is on, you can switch off it by touching “Holiday” again, and the “” will be off.

When the holiday function is on, the ice maker will automatically turn off. And it will retain the setting when power off.

Note: Do not store any food in the fridge during this time, or they will soon go off.



“Fridge temperature control”

You can touch the “Fridge” icon to activate the mode to control the fridge temperature. When you touch the button continuously, the temperature will be set as the following sequence.

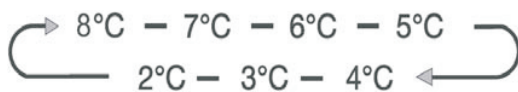

If you want to decrease the time needed to cool products in the Fridge, please touch and hold this button for 3 seconds, the super cool “” will be shined, the fridge temperature setting displays 2°C. Super cool automatically switches off after 3 hours, and the refrigerator temperature setting will revert back to the previous setting. When super cool function is on, you can touch and hold the “Fridge” to switch it off. And it will not retain the Super Cool function when power off.



“Freezer temperature control”

You can touch the “Freezer” button to activate the mode to control the freezer temperature. When you press the button continuously, the temperature will be set as the following sequence.



Touch and hold the “Freezer” for 3 seconds, the icon “” will be light, the freezer temperature setting displays -24°C.

Super Freezer can quickly lower frozen temperature and freeze your food faster than usual. This can the vitamins and nutrition of fresh food and keep your food longer.

In case of the maximum amount of food to be frozen, we recommend that you let the appliance operates for 6 hours first.



Super freeze automatically switches off after 26 hours, and the freezer temperature setting will revert back to the previous setting.

When super freeze function is on, you can touch and hold “Freezer” for 3 seconds to switch off Super Freeze function. And it will not retain the Super Freeze function when power off.

“Dispenser control”

You can't get any ice or water if **freezer** door is opened or the Child Lock is on.

You can touch the Ice Type button to change the ice type.

Each time you touch the Ice Type button, the cubed and crushed ice modes alternate and the Cubed “” or Crushed “” ice icon lights up, indicating your selection.

If you don't need ice, turn the function off to save on water and energy consumption.(See Ice Off above.)

If you need water, please touch the “Water” button, and the water icon “” will light up.

When dispensing, the dispenser LED will be on, and will continue for 6 seconds after dispensing.

“Water filter usage”

After you use the water filter for about 6 months, The filter icon “” will blink, and the buzzer will sound 3 times, then you should need to change the filter.

After you install the new water filter, touch and hold the button “Eco” for 3 seconds to reset the filter.

If water is not dispensing or dispensing slowly, you need to replace the water filter because the water filter is clogged.

Some areas have large amounts of lime in their water, which causes the water filter to clog more quickly.



“Energy Save”

You can touch this button to turn Energy Saver mode on and off .

When you turn Energy Saver on, the Energy Saver icon “” lights. The temperature of the fridge is automatically switched to 8°C and the freezer to -15°C. If Energy Saver is off and the icon goes off.

Note!

- The control panel will light up when the door open or touch any button.
- The light will go off without touching any button or doors closed for one minutes.
- When the refrigerator is powered on, all the icon of control panel will light up for 3 seconds, and with a long buzzing. The Child Lock is off. And the temperature setting reverts back to the previous setting.

4.2 Using the appliance

This section tells you how to use most of the useful features. We recommend that you read through them carefully before using the appliance.

1. Adjust the door

When you found the doors are not at the same level, you can use the screwdriver to adjust the fridge door. Only the fridge door can be adjusted.

When the freezer door is upper than the fridge door. First, you can use the screwdriver to turn the bolt anticlockwise on the lower hinge that can make the fridge door go up. Then use the screwdriver to locking the nut.

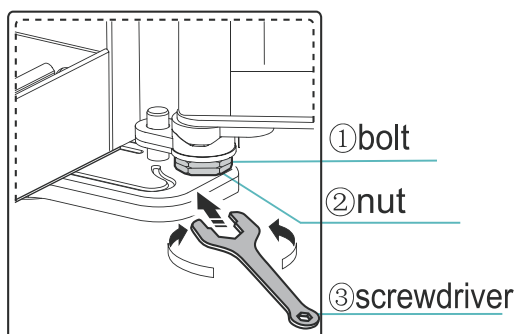
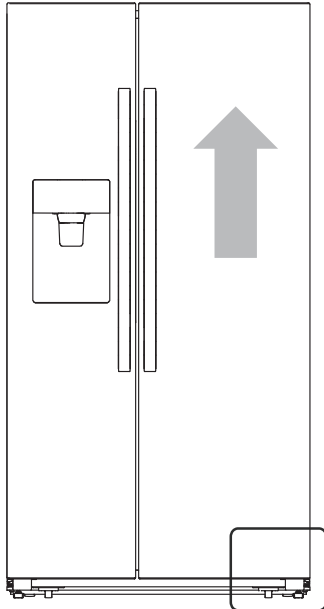

2. Using your refrigerator compartment

The refrigerator compartment is suitable for storage of vegetables and fruit. Food inside shall be packed to store in order to avoid losing moisture or flavor permeating into other foods.

Caution! Never close the refrigerator door while the shelves, crisper and/or telescopic slides are extended. It may damage both them and the refrigerator.

Glass shelves and Door racks

The refrigerator compartment is provided with several glass shelves and several different door racks, which are suitable for the storage of eggs, canned liquid, bottled drinks and packed food. They can be placed a different heights according to your need. But do not place too many heavy things in racks. Before you lift up the door shelf vertically, please take the food out.

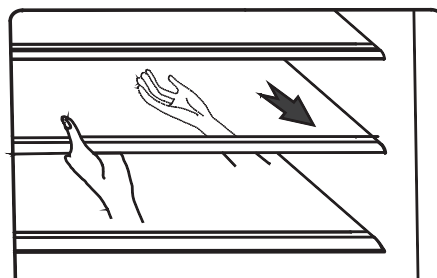
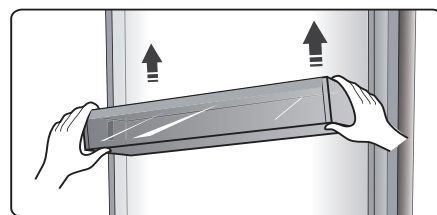

Note: All the door racks and shelves can be taken out to be cleaned.

When you remove the shelves, gently pull them forward until the shelf comes clear of the shelf guides.

When you return the shelves, make sure there is no obstacle behind and gently push the shelf back into the position.

Bottle rack

It is for storing bottled wine or drinks.

Note: Please use gently when you removed the bottled wine or drinks. It can be taken out to be cleared or you adjust to save the shelf space.

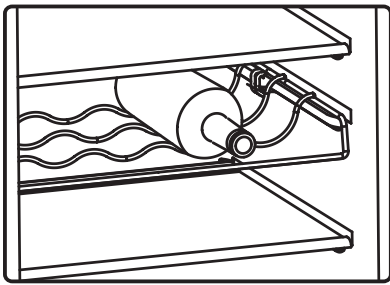

Drawers

It is suitable for storage of fruits and vegetable. And it can be taken out to be cleared.

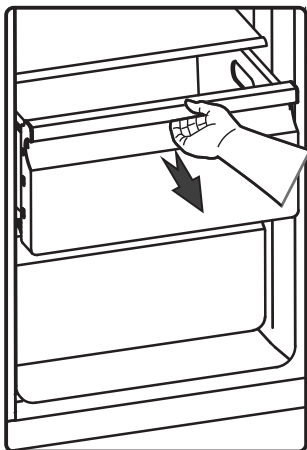

3. Using your freezer compartment

The freezer compartment is suitable for storage of foods required to be frozen, such as meat, fish, ice cream and other perishable food.

Caution! Ensure that bottles are not left in the freezer for longer than needed as freezing may cause the bottle break.

Bottled or canned liquid which could explode caused by volume expanding are not allowed to be stored there.

4. Using the dispenser

You can choose the type of ice or water by touching the “Cubed” or “Crushed” or “Water” button.

When you choose ice type, push the dispenser gently with your glass. Ice will be released from the dispenser. Make sure the glass is in line with the dispenser, or the ice releasing will bounce out.

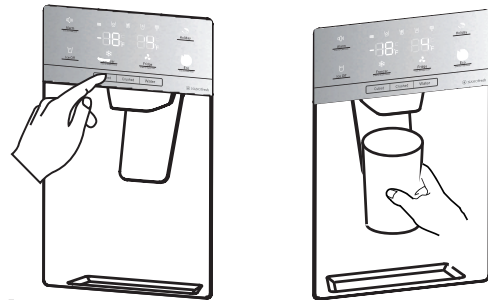

Note:

- If you select Cubed Ice after using the Crushed Ice feature, a small amount of residual crushed ice might be produced.
- Do not immediately removing your cup or glass from under the dispenser after dispensing water or ice you need. It should be wait for 2 or 3 seconds to prevent spills.
- Do not pull the lever out. You could damage or break the lever's spring.
- The dispensed water is cool, not icy cold. When you want colder water with ice, dispense ice to your glass first, then fill with water from dispenser.

5. Using the Ice Maker

If you want to remove the Ice Bucket. Please hold the handle as shown in the figure below. Then lift up and pull the Ice Bucket out slowly to prevent damage. When you put it back, please make sure the two side of Ice Bucket is wedged into the buckles.

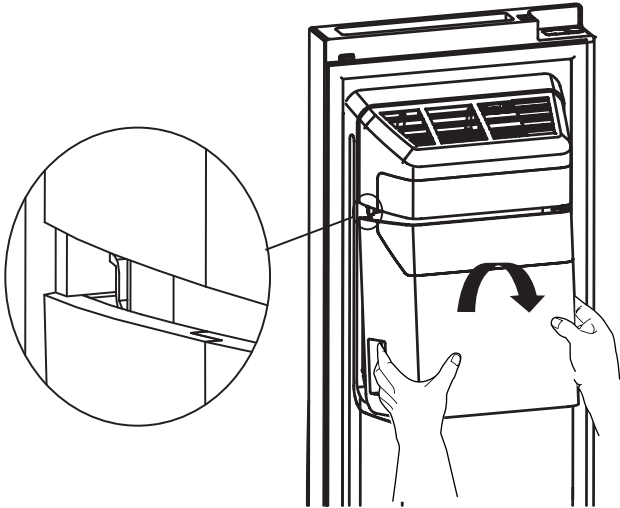

Note!

- When the ice maker dumps ice into the bucket, any sounds you hear are part of normal operation.
- If you do not dispense ice for a long periods of time, Ice may clump in the Ice Bucket. If this occurs, please remove all the ice and empty the bucket.
- If you are going on a long vacation or business tri and won't be using the ice dispensers for period of time, please close the water valve to prevent leaks.
- If ice doesn't come out, please check for any ice stuck in the chute and remove it. Or pull out the Ice Bucket and check for any ice cubes clump, then remove them.

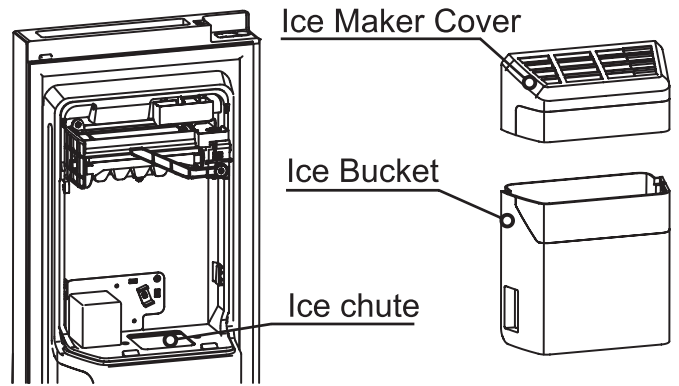

- The first batch of ice cubes after installation may be small, because air has entered the water line. Any air will be purged during normal use. If the ice cubes is still small, please check the water is circulated in line, or water valve is opened large enough, or the water is at a high presser properly.
- To clean the Ice Bucket, wash with a mild detergent, rinse well, and dry thoroughly it. Do not use harsh or abrasive cleaners or solvents.
- Before removing back the Ice Bucket, please check the two coupler below are at a suitable angle for a rightly connecting. If not, please turn the Ice bucket coupler to a right angle to match the motor coupler.

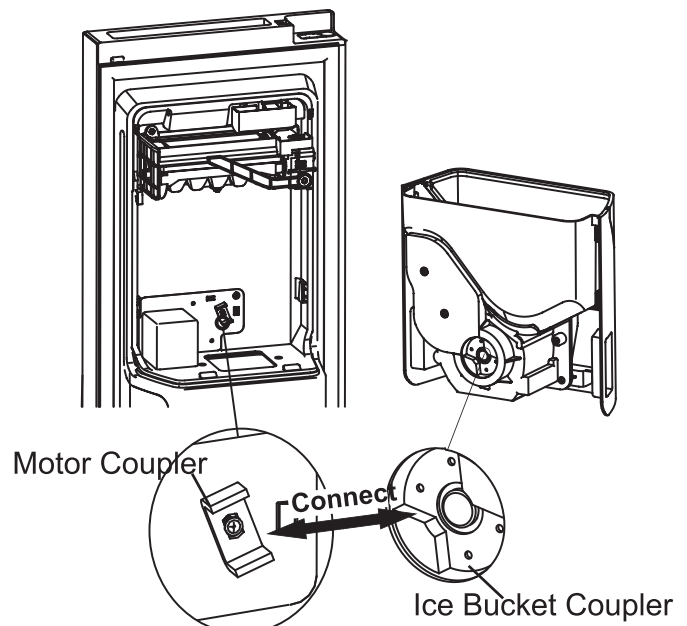

- If you want more space to store foods, you can replace the Ice Bucket with the storage box. And the “Ice Off” should be set on to make sure that ice maker is off.

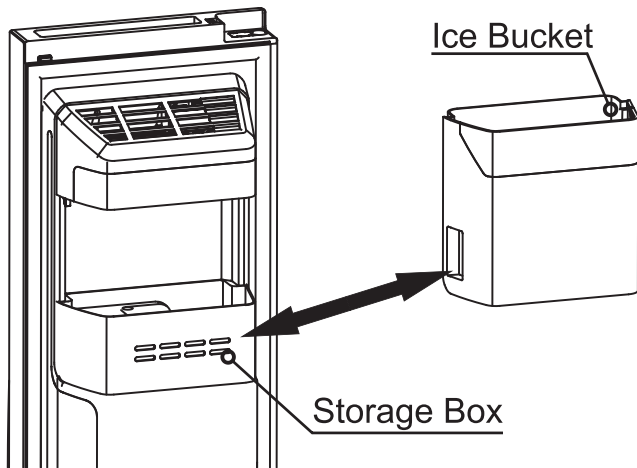

Warning!

- Do not put your fingers, hands, or any other unsuitable objects in the ice chute or ice bucket. This can cause personal injury or material damage.
- Do not allow your children to hang off the dispenser or ice bucket. This could cause injury.
- The ice maker requires a water line connection. Outside the refrigerator, the water line should be connected with a water filter and the tap. It is recommended a **suitable qualified person to do this.**
- **To operate properly, the ice maker requires water pressure of 207~689 Kpa.**

4.3 Defrost mode

4.3.1 Start condition

When compressor accumulated running time reach the setting point (depends on the environment temperature),it will enter defrost mode automatically.

4.3.2 Defrost flow

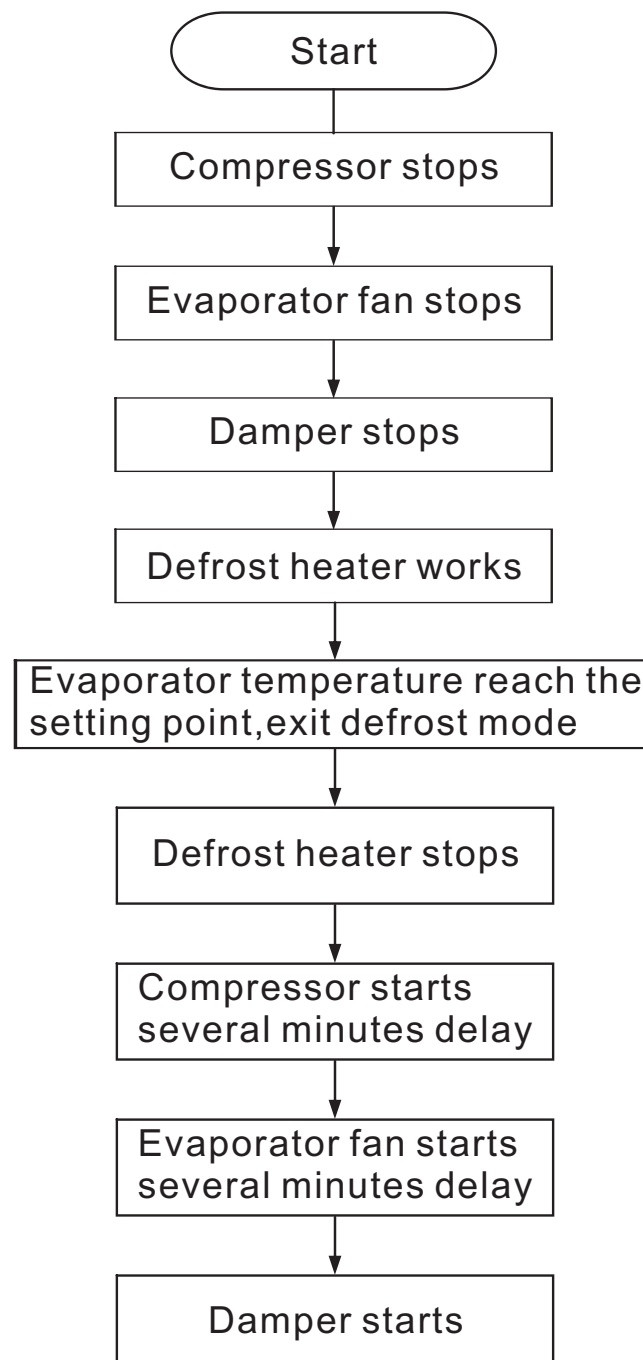

4.4 Compulsory Defrost mode

4.4.1 Start condition

Keep refrigerator door and freezer door closed for 10 minutes after power-on, touch and hold “Ice off” button and “Freezer” button at the same time for 5 seconds, it will enter compulsory defrost mode after a long buzzing sound.

4.4.2 Compulsory defrost flow

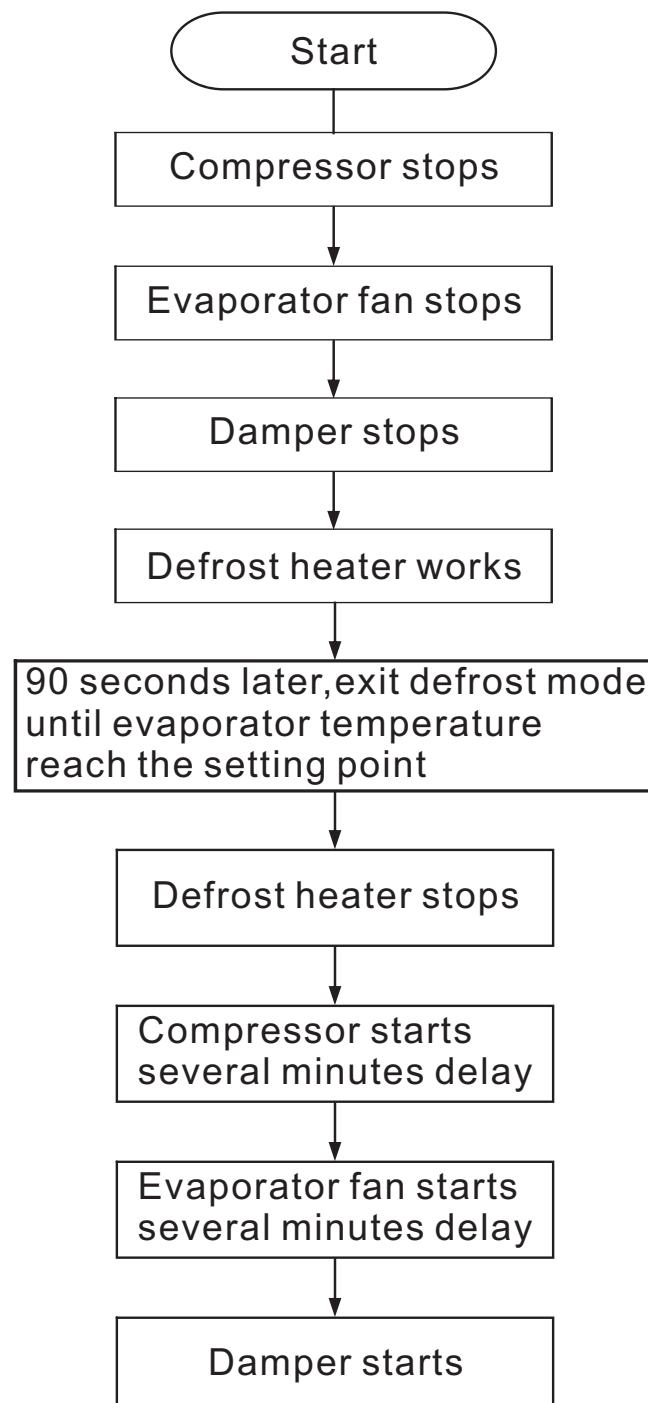

4.5 Error display

4.5.1 Error code

Code	Display area	problem
E1	Refrigerator temperature display area	Refrigerator sensor malfunctions
E3	Freezer temperature display area	Freezer sensor malfunctions
E4	Freezer temperature display area	Defrost sensor malfunctions
E0	Freezer temperature display area	Environment sensor malfunctions
E9	Freezer temperature display area	Ice maker sensor malfunctions
Eb	Freezer temperature display area	Ice maker malfunctions
Ec	Refrigerator temperature display area	Communication sending malfunctions
Er	Refrigerator temperature display area	Communication receiving malfunctions

4.5 Error display

4.5.2 Checking method

4.5.2.1 Environment sensor error

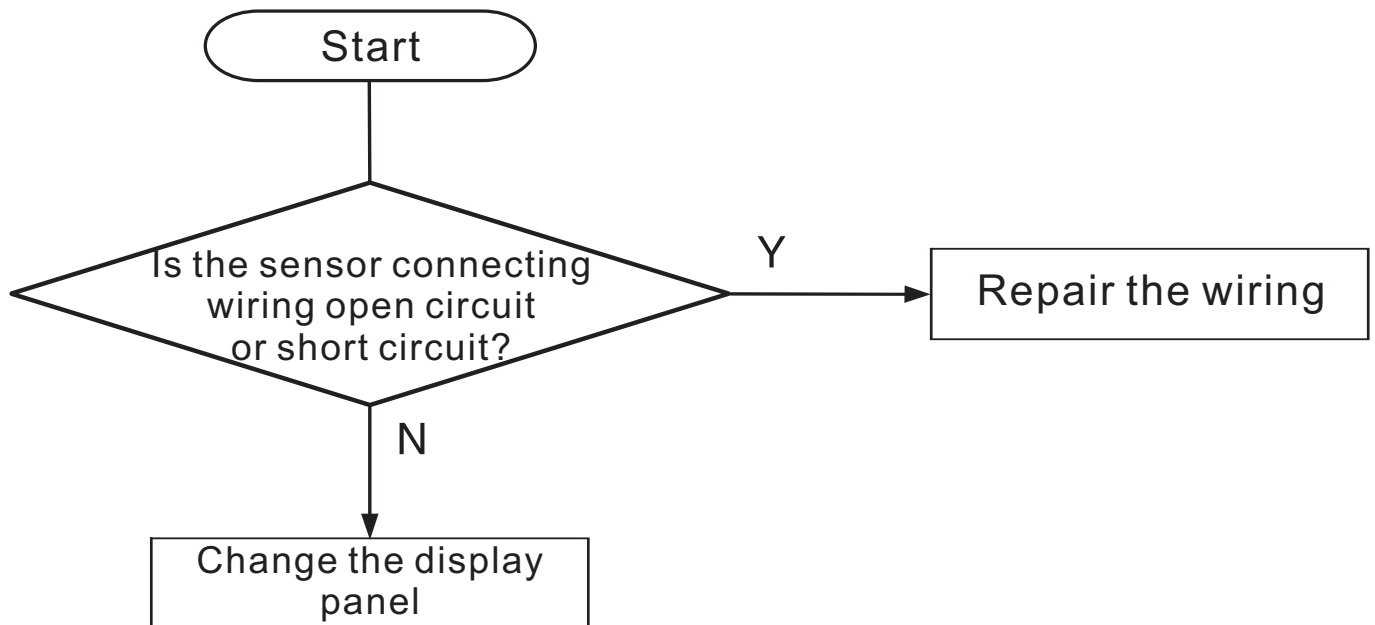

4.5.2.2 Other sensors error

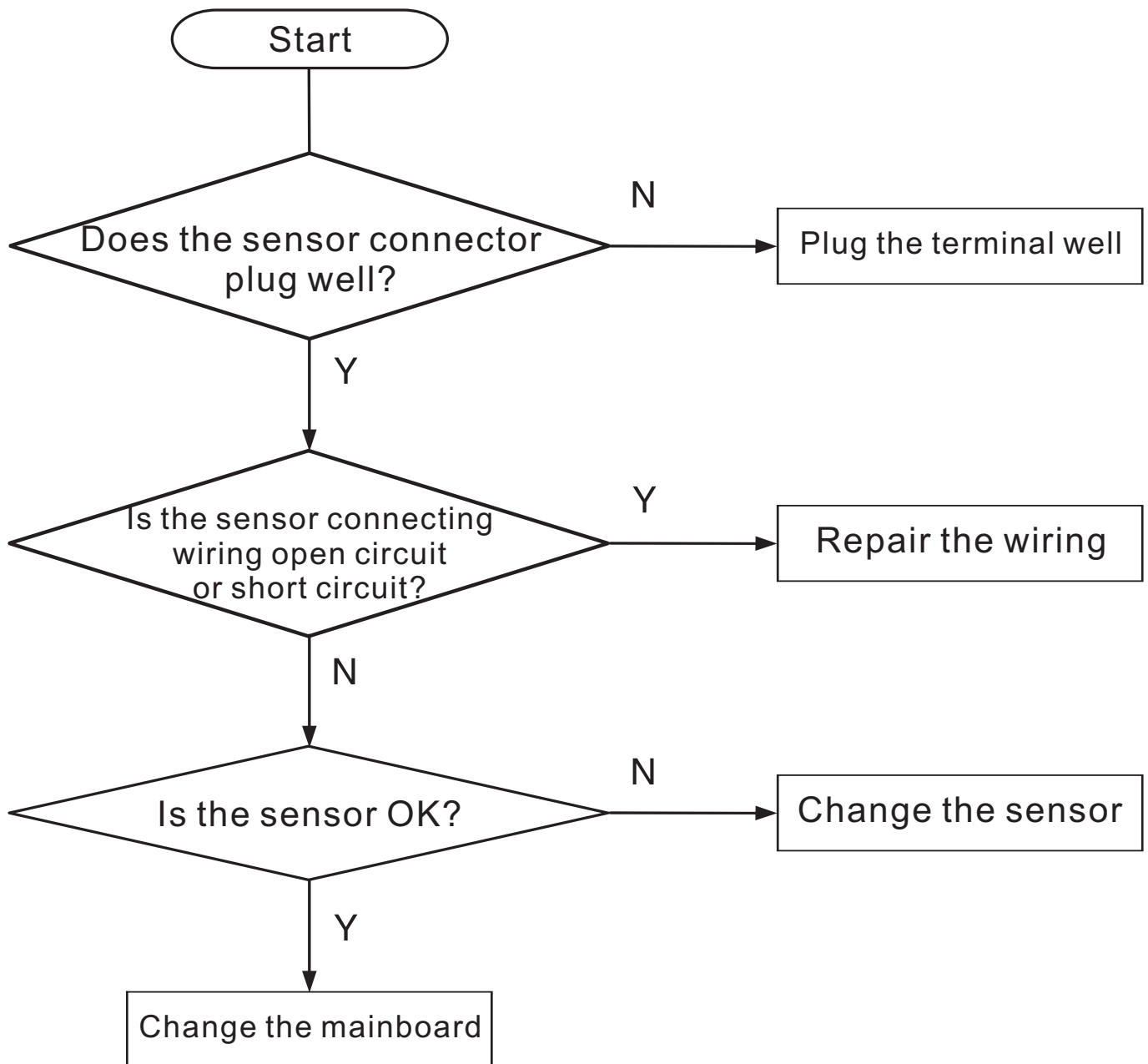

4.5.2.2 Other sensors error

Note:

- 1.Refrigerator sensor corresponding pin No.8 and No.12 on CN5 connector of mainboard.
- 2.Freezer sensor corresponding pin No.9 and No.12 on CN5 connector of mainboard.
- 3.Evaporator sensor corresponding pin No.10 and No.12 on CN5 connector of mainboard.
- 4.Ice maker sensor corresponding pin No.11 and No.12 on CN4 connector of mainboard.

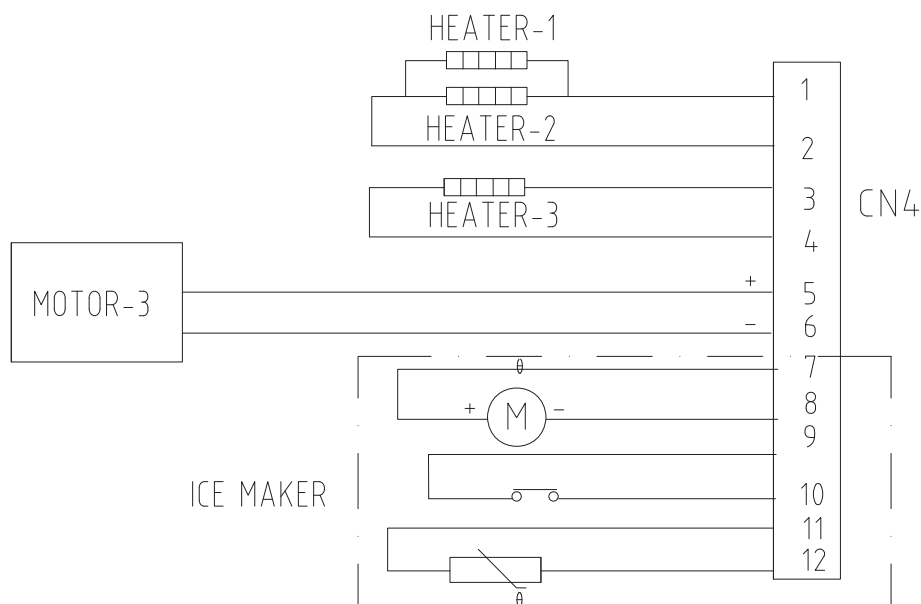
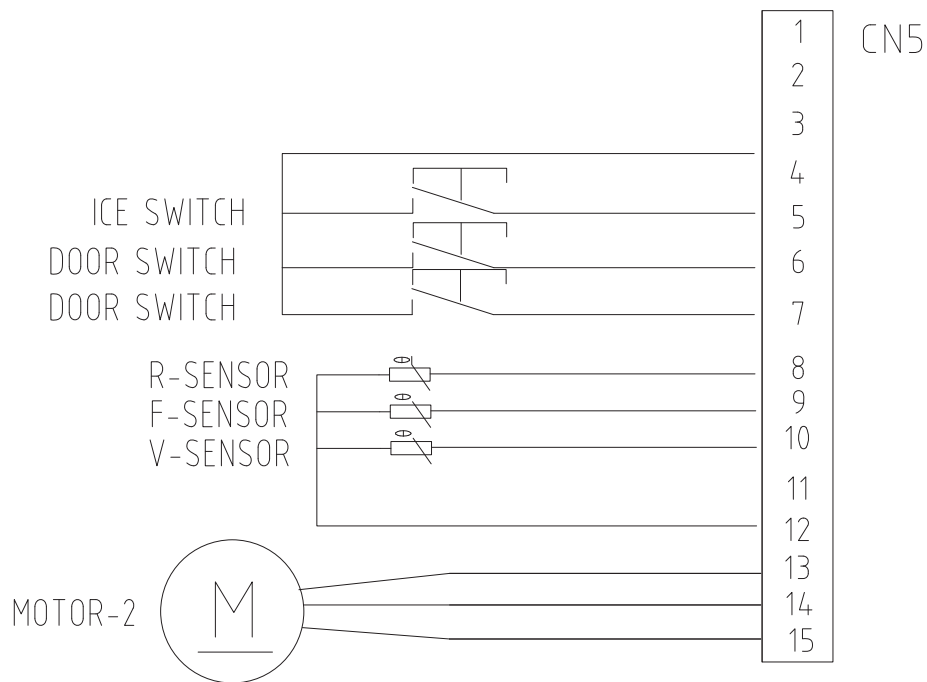

4.5.2.3 Ice maker error

Eb error:

1.Check the connecting wiring between mainboard and ice maker (corresponding pin No.7~10 on CN4 connector of mainboard,as the drawing below) and repair if it is broken.

2.Input 12V power to pin No.7 and No.8 on CN4 connector of mainboard,check the ice maker can positive rotating(Red wiring connect power,white wiring connect GND) and negative rotating (white wiring connect power,red wiring connect GND) normally or not. If it is abnormal,change the ice maker or mainboard.

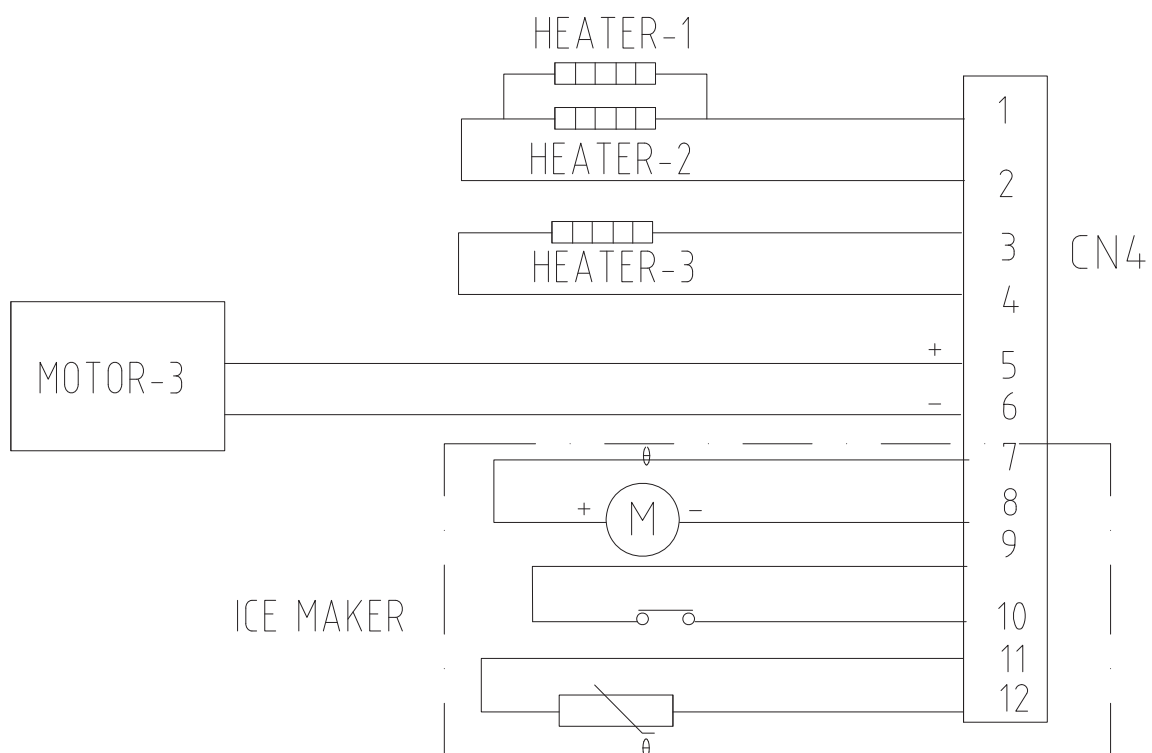

4.5.2.4 Communication error

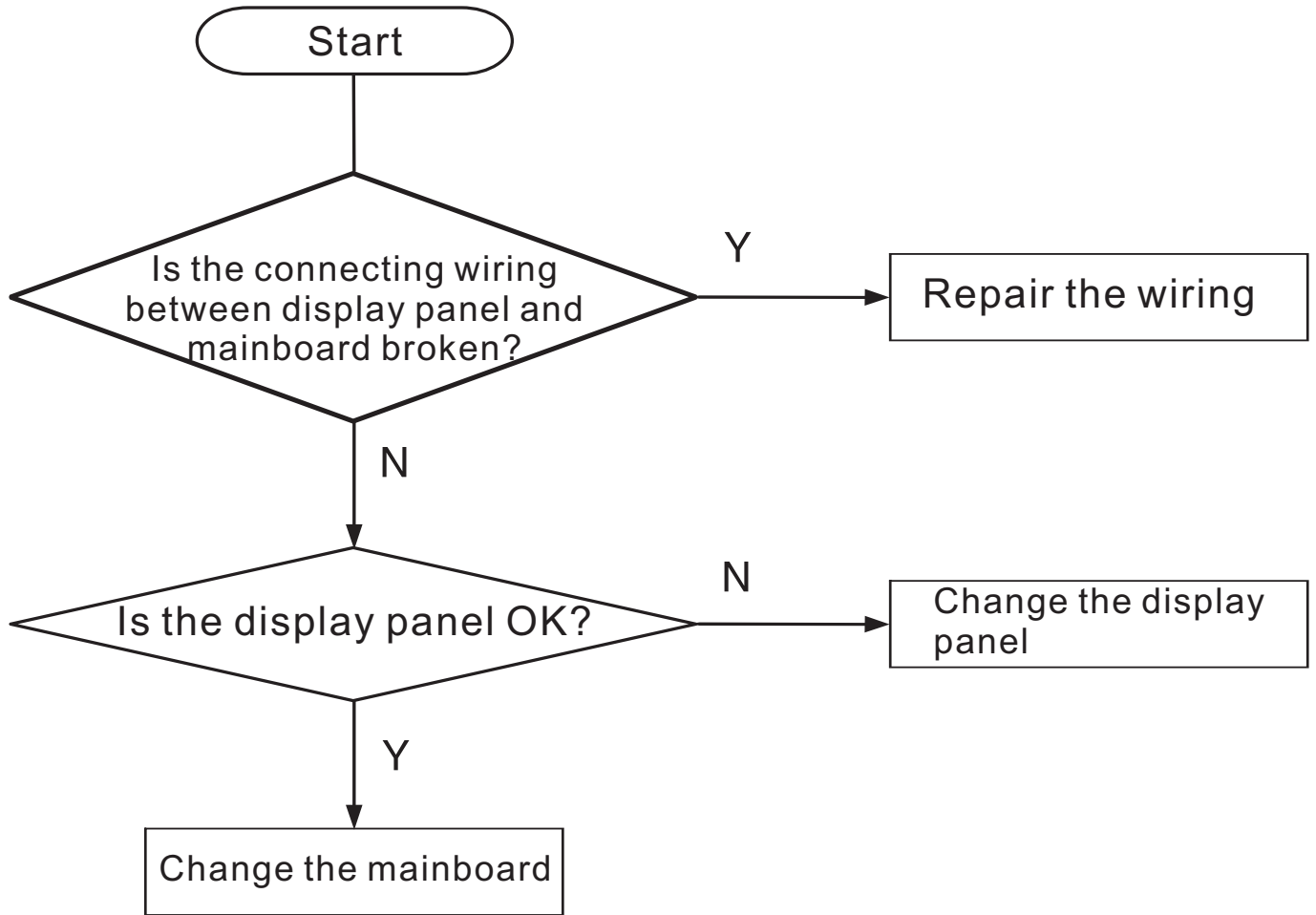

Note:

The display panel corresponding pin No.5~8 on CN7 connector of the mainboard,as the drawing below.

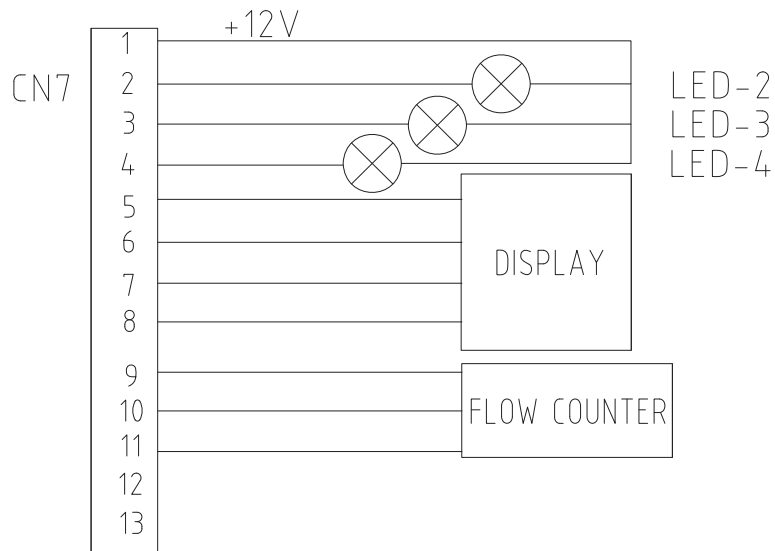

5.1 Common problem and checking

Problem	Possible cause & Solution
Appliance is not working correctly	Check whether the power cord is plugged into the power outlet properly
	Check the fuse or circuit of your power supply, replace if necessary
	The ambient temperature is too low. Try setting the chamber
	It is normal that the freezer is not operating during the automatic defrost cycle, or for a short time after the appliance
Odours from the compartments	The interior may need to be cleaned
	Some food, containers or wrapping cause odours
Noise from the appliance	<p>The sounds below are quite normal:</p> <ul style="list-style-type: none"> ● Compressor running noises. ● Air movement noise from the small fan motor in the freezer compartment or other compartments. ● Gurgling sound similar to water boiling. ● Popping noise during automatic defrosting
	<p>Other unusual noises are due to the reasons below and may need you to check and take action:</p> <ul style="list-style-type: none"> ● The cabinet is not level. ● The back of appliance touches the wall
The motor runs continuously	<ul style="list-style-type: none"> ● It is normal to frequently hear the sound of the motor, it will need to run more when in following circumstances: Temperature setting is set colder than necessary. ● Large quantity of warm food has recently been stored within the appliance. ● The temperature outside the appliance is too high. ● Doors are kept open too long or too often. ● After your installing the appliance or it has been switched off

Problem	Possible cause & Solution
A layer of frost occurs in the compartment	Check that the air outlets are not blocked by food and ensure food is placed within the appliance to allow sufficient ventilation. Ensure that door is fully closed. To remove the frost, please refer to cleaning and care chapter.
Temperature inside is too warm	You may have left the doors open too long or too frequently; or the doors are kept open by some obstacle; or the appliance is located with insufficient clearance at the sides, back and top.
Temperature inside is too cold	Increase the temperature by following the "Display controls" chapter.
Doors can't be closed easily	Check whether the top of the refrigerator is tilted back by 10-15mm to allow the doors to self close, or if something inside is preventing the doors from closing.
Water drips on the floor	The water pan (located at the rear bottom of the cabinet) may not be properly leveled, or the draining spout underneath the top of the compressor depot may not be properly positioned to direct water into this pan, or the water spout is blocked, or the water is not fully inserted into the connector. You may need to pull the refrigerator away from the wall to check the pan and spout and connector.
The light is not working	<ul style="list-style-type: none"> ● The LED light may be damaged. Refer to replace LED lights in cleaning and care chapter. ● The control system has disabled the lights due to the door being kept open too long, close and reopens the door to reactivate the lights.
Ice is not dispensing	<ul style="list-style-type: none"> ● Did you wait for 4 hours after installation of the water supply line before making ice? if it is not sufficiently cool, it may take longer to make ice, such as when first installed. ● Is the water line connected and the water valve open? ● Did you manually stop the ice making function? Make sure you have set the Cubed or Crushed mode on. ● Is there any ice blocked within the ice maker bucket or ice chute? ● Is the freezer temperature too warm? Try setting the freezer temperature lower.

Problem	Possible cause & Solution
Water dispenser is not functioning	<ul style="list-style-type: none"> ● Is the water line connected and the water valve open? ● Has the water line been crushed or kinked? Make sure the water line is free and clear of any obstruction. ● Is the water tank frozen because the refrigerator temperature is too low? Try selecting a warmer setting on the display panel. ● Check if the filter is properly installed.If it is not properly installed,the water dispenser may not work.
You can hear water bubbling in the refrigerator	This is normal. The bubbling comes from the refrigerant coolant liquid circulating through the refrigerator.

5.2 Faulty start

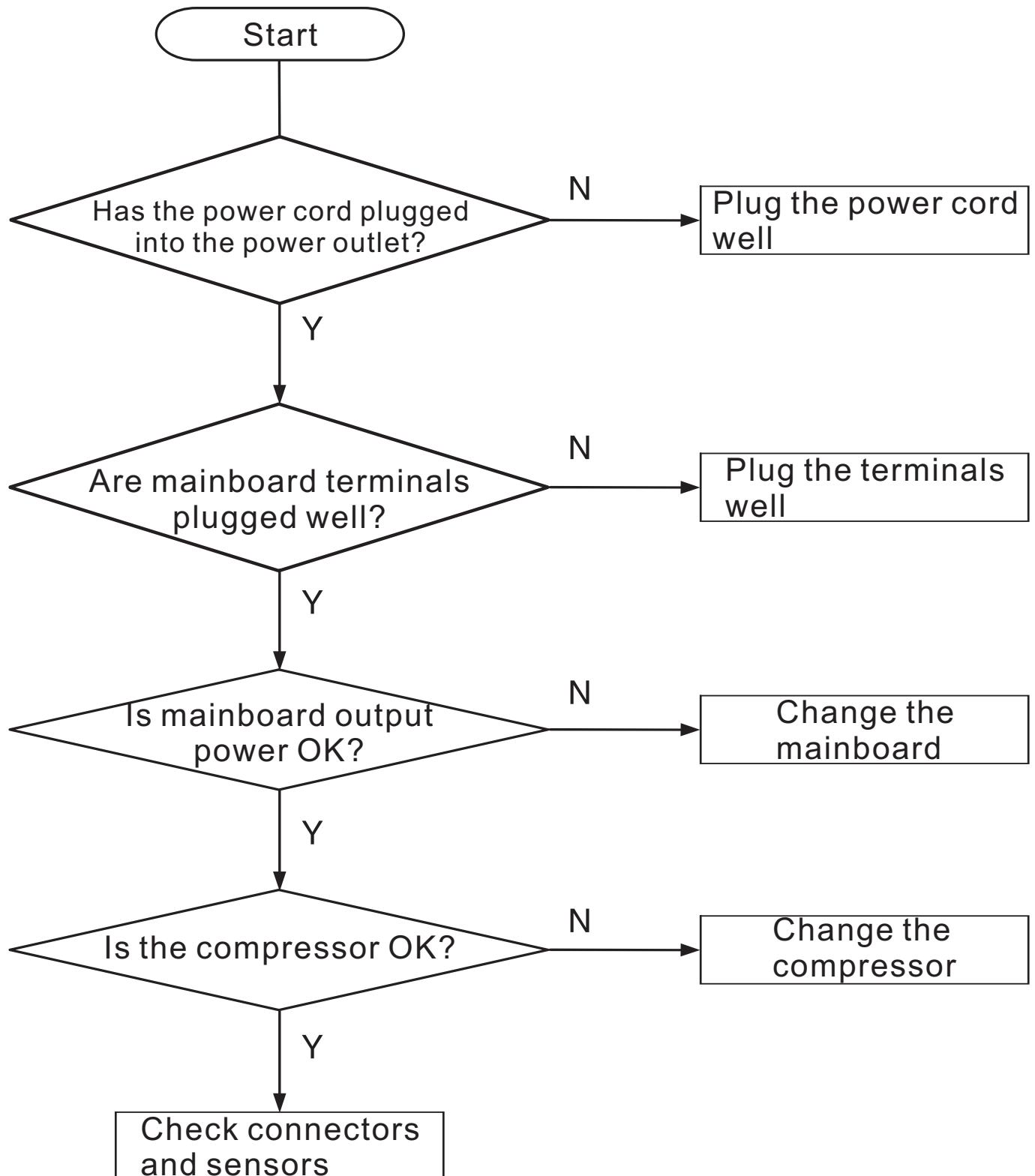

5.3 Refrigeration failure

5.3.1 Freezer compartment

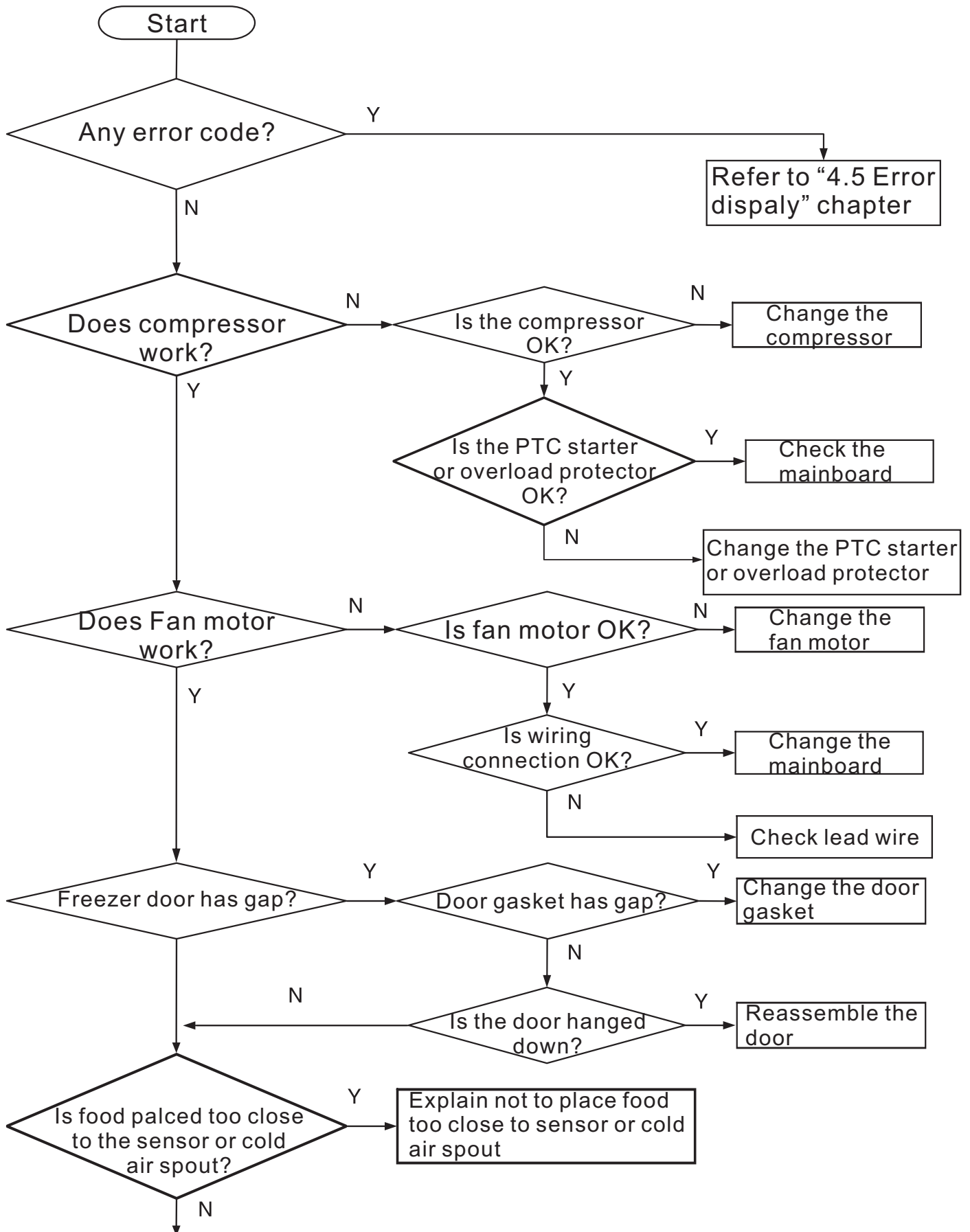

5.3 Refrigeration failure

5.3.1 Freezer compartment

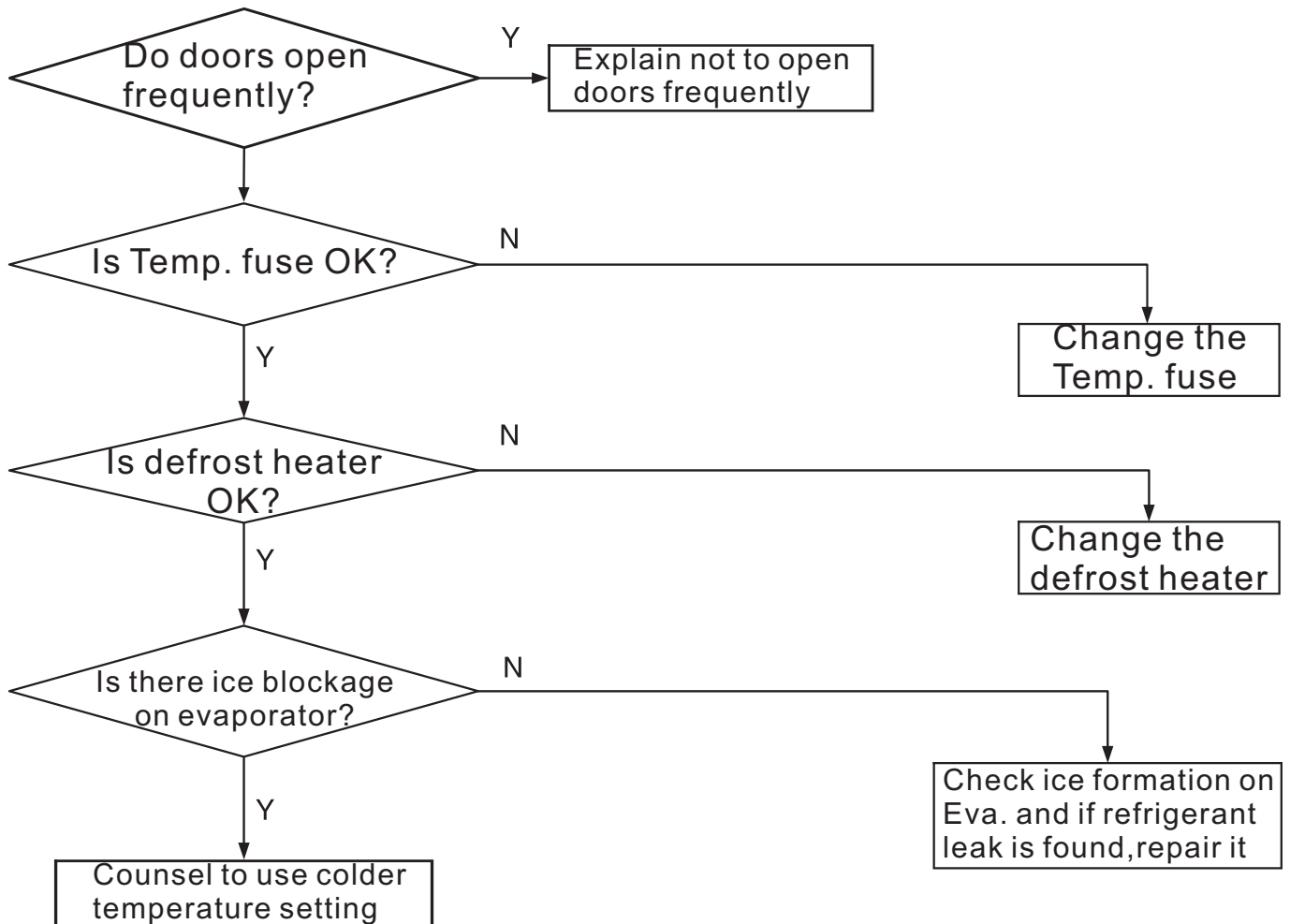

5.3 Refrigeration failure

5.3.2 Refrigerator compartment

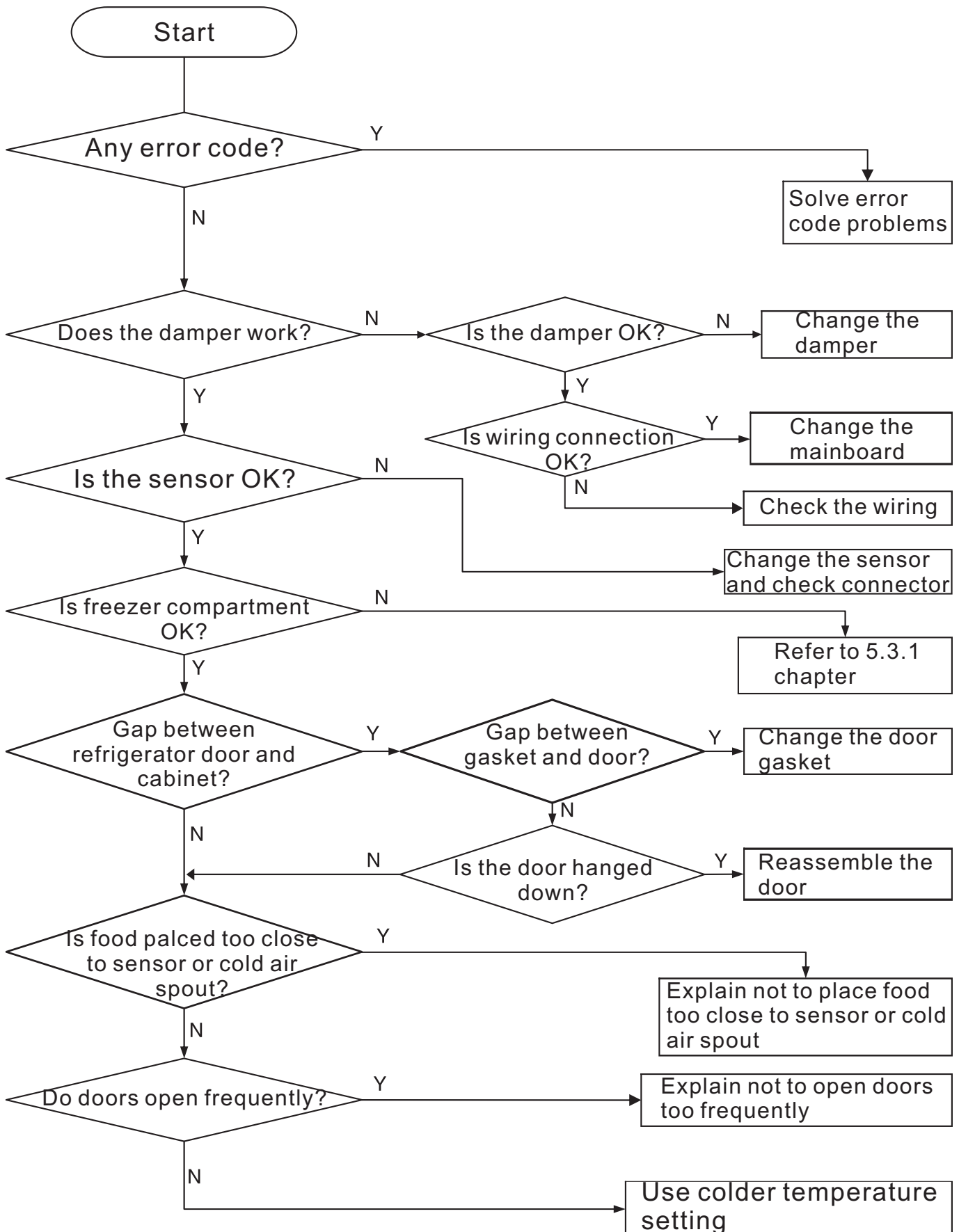

5.4 Thick frost in freezer compartment

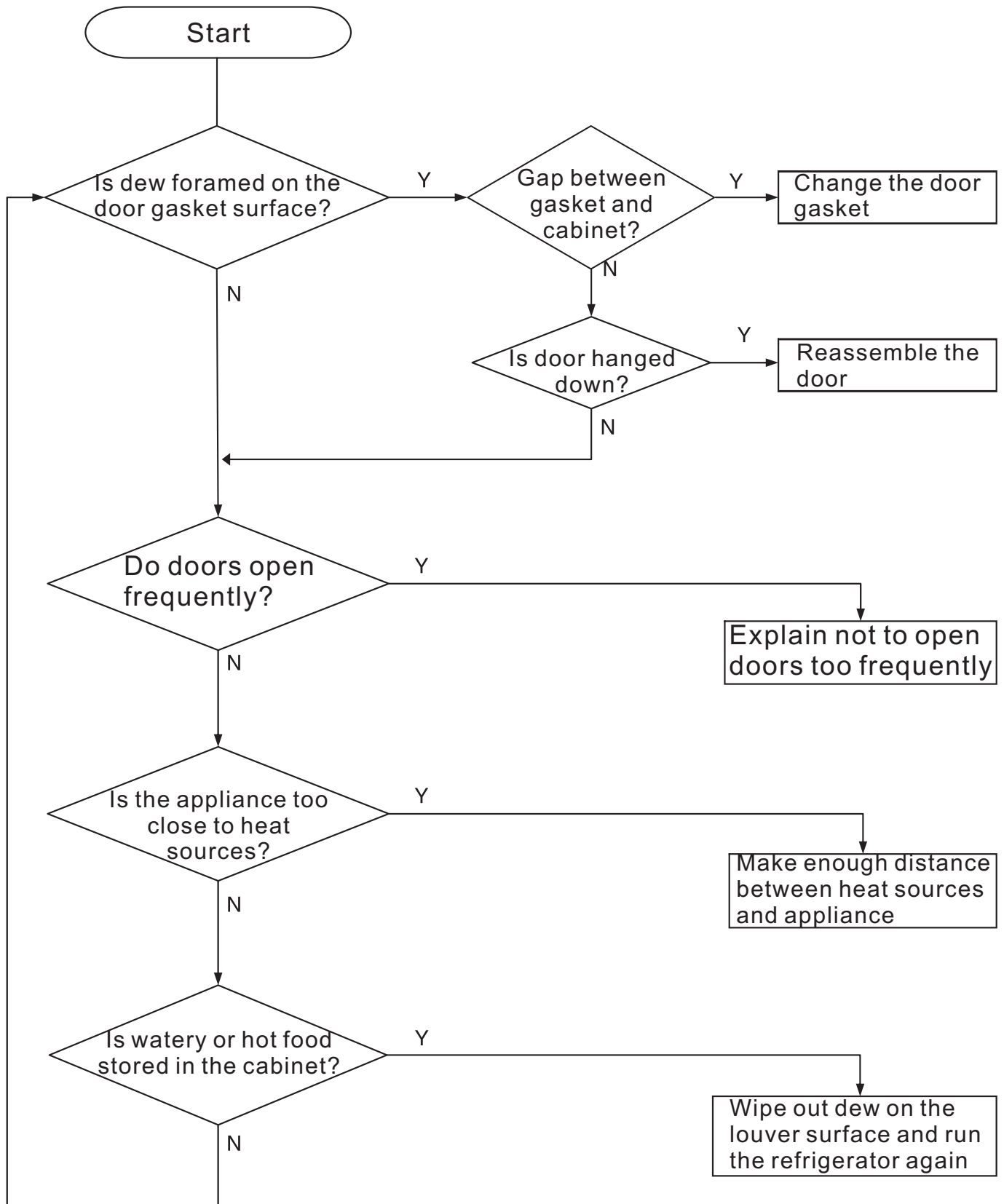

5.5 Dew in refrigerator compartment

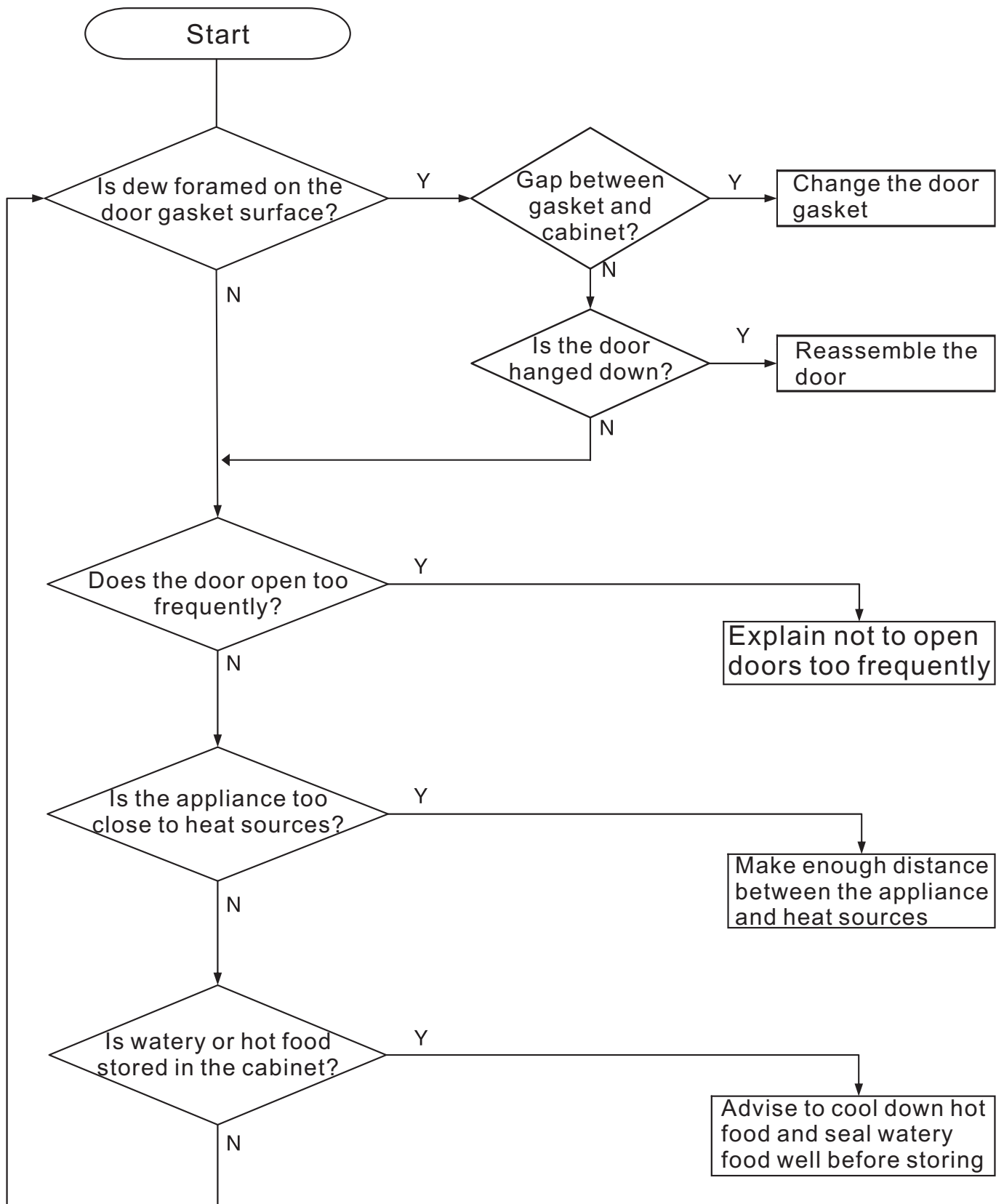

5.6 Low temperature of vegetable vase

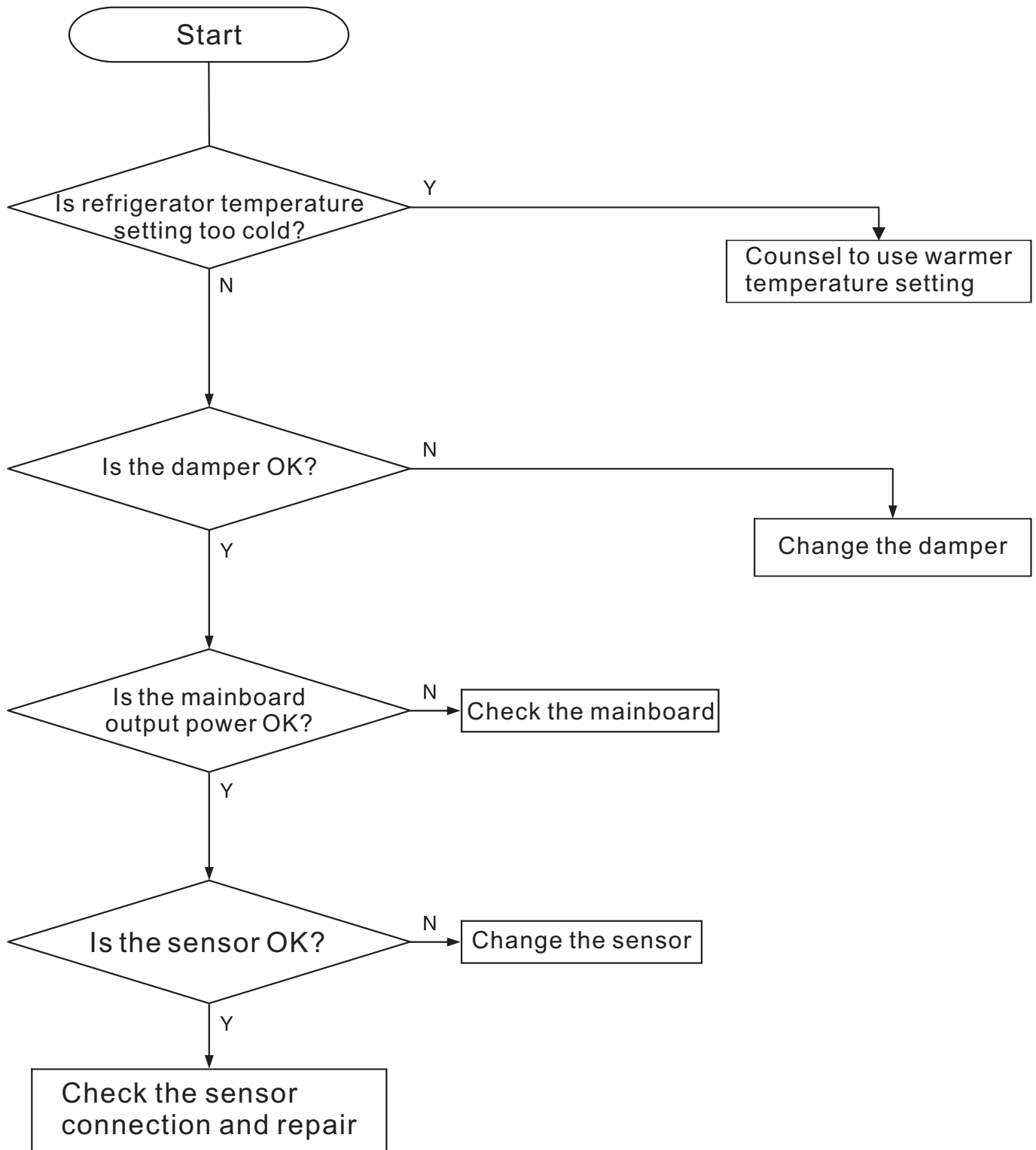

5.7 Breaking of light

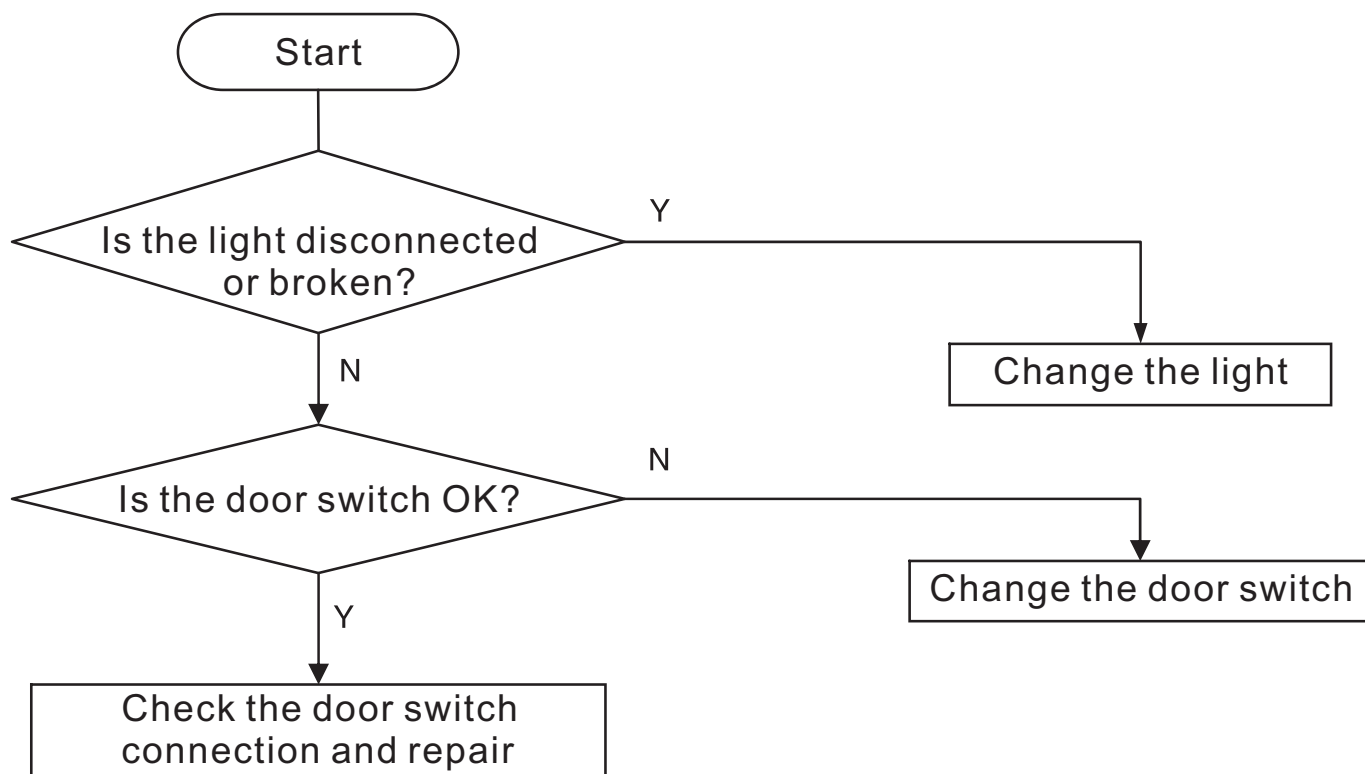

5.8 Noise

5.8.1 Compressor noise

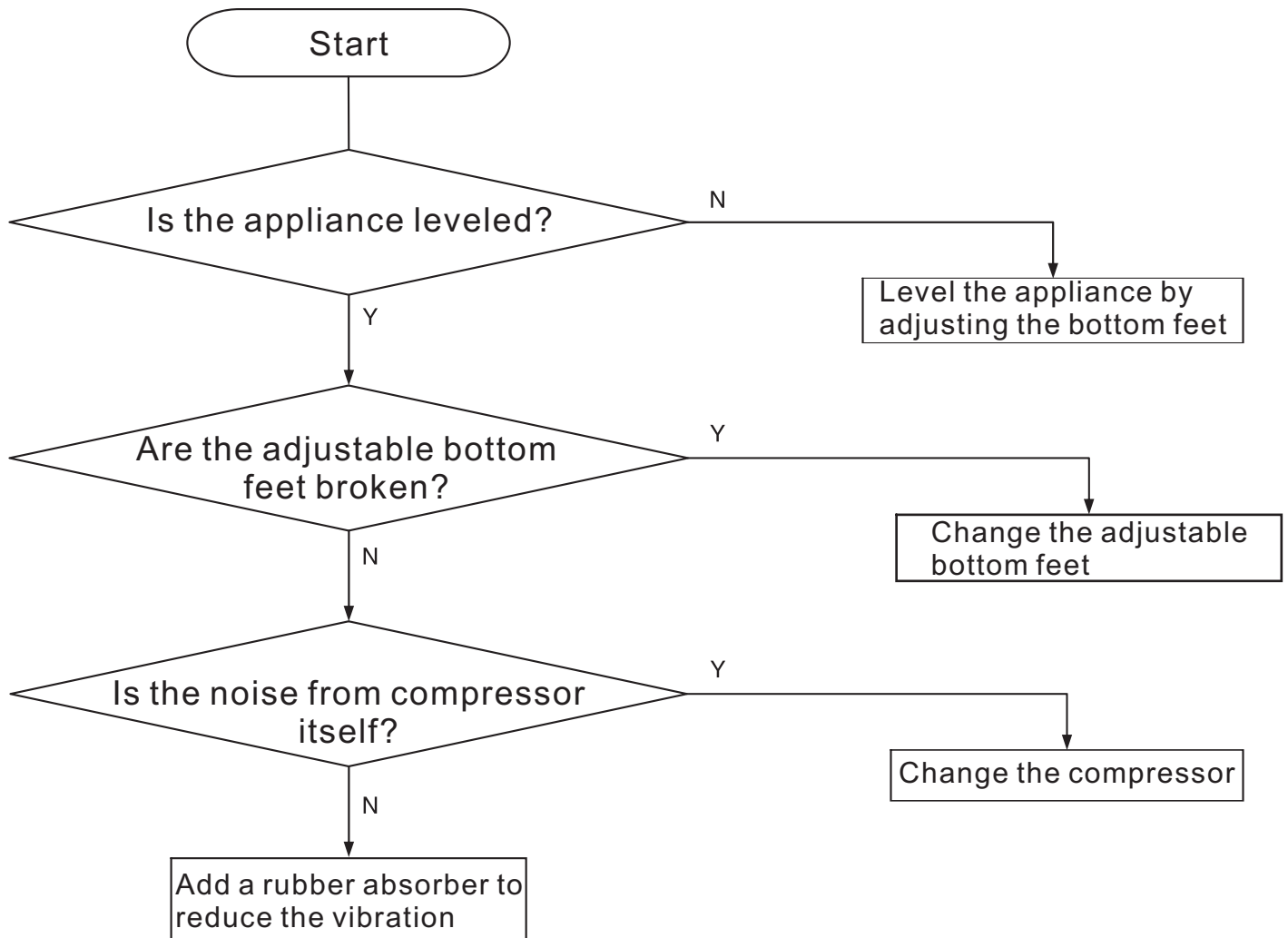

5.8 Noise

5.8.2 Refrigerator flowing noise

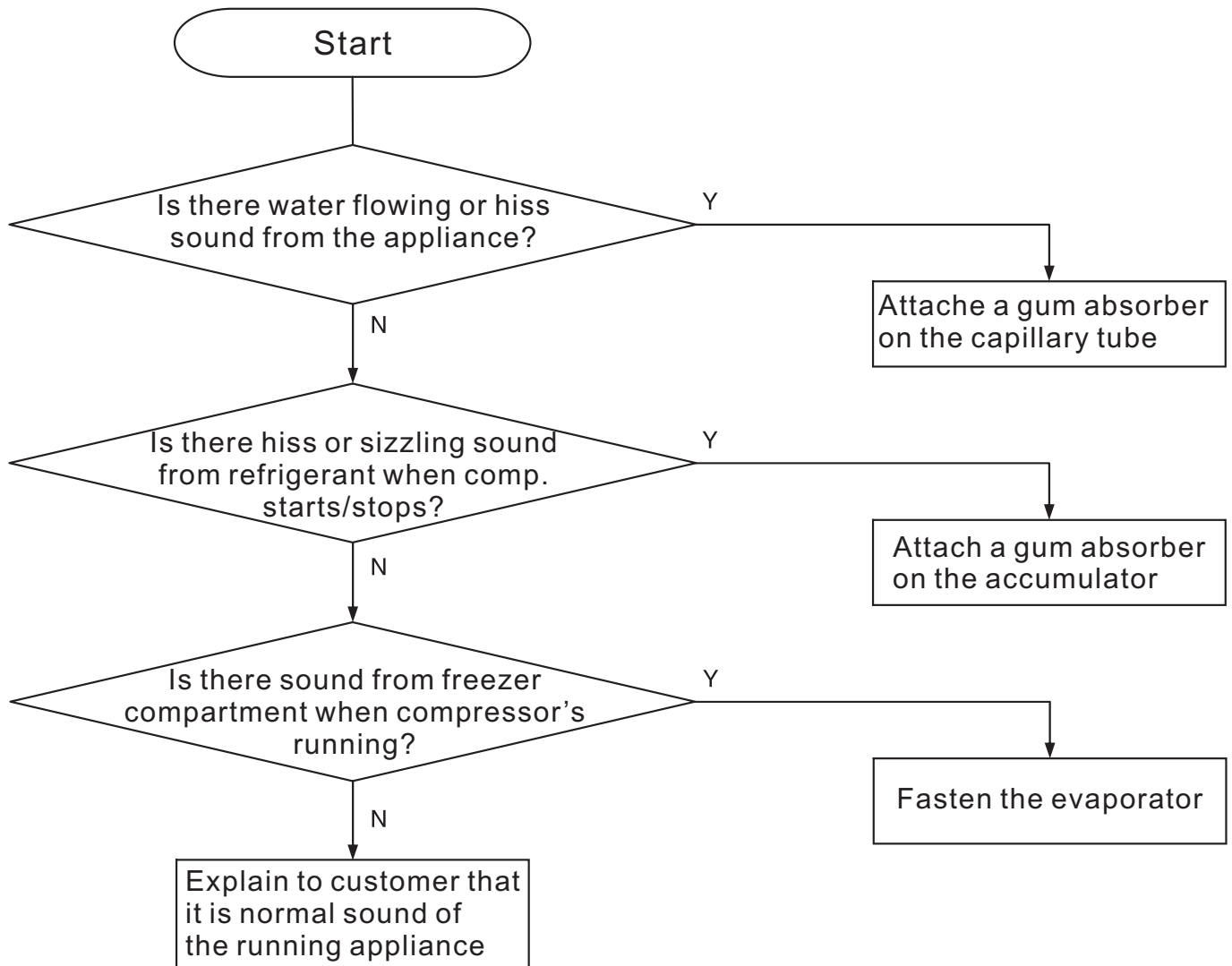

5.8 Noise

5.8.3 Fan motor noise

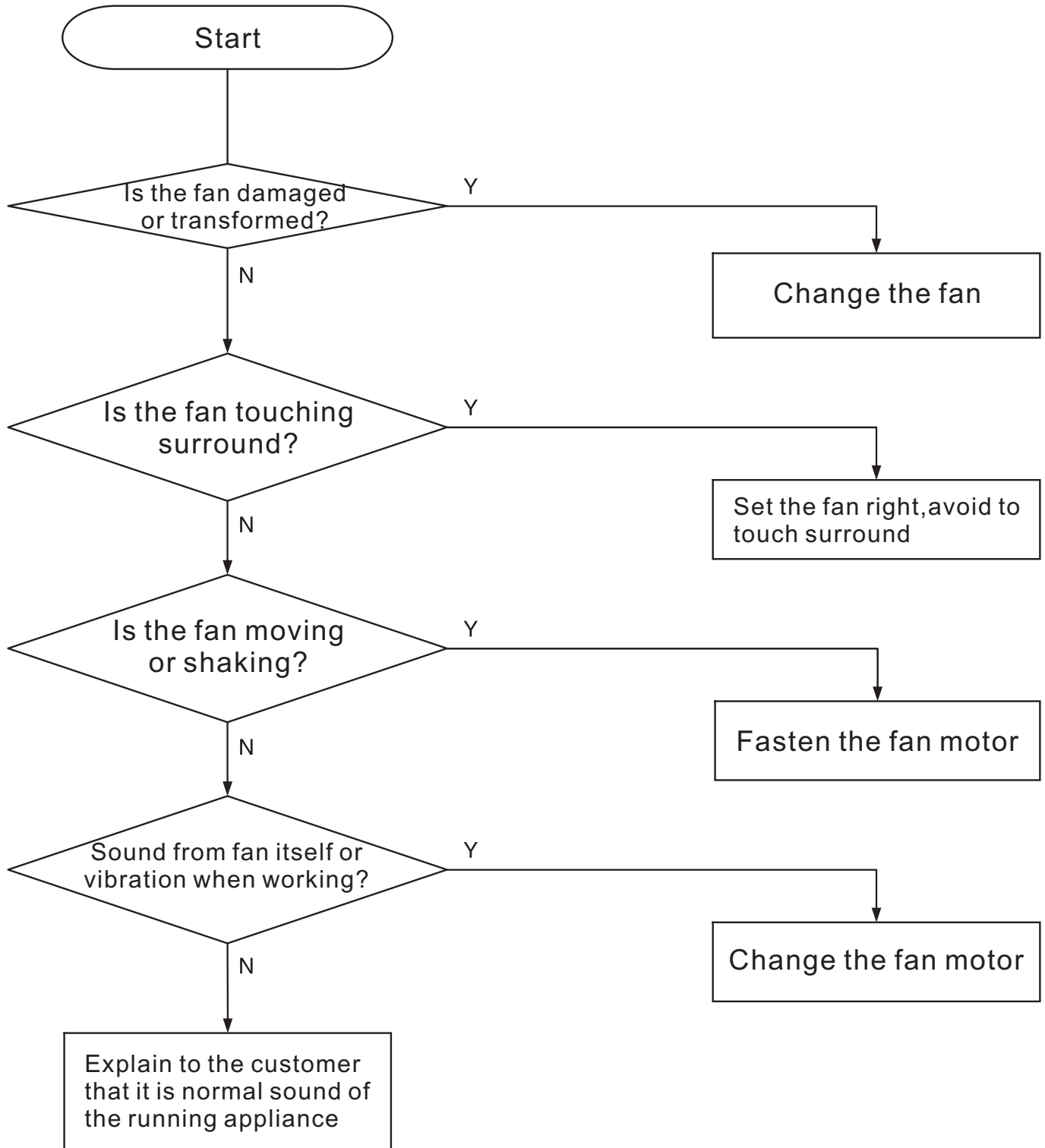

5.8 Noise

5.8.4 Pipe noise

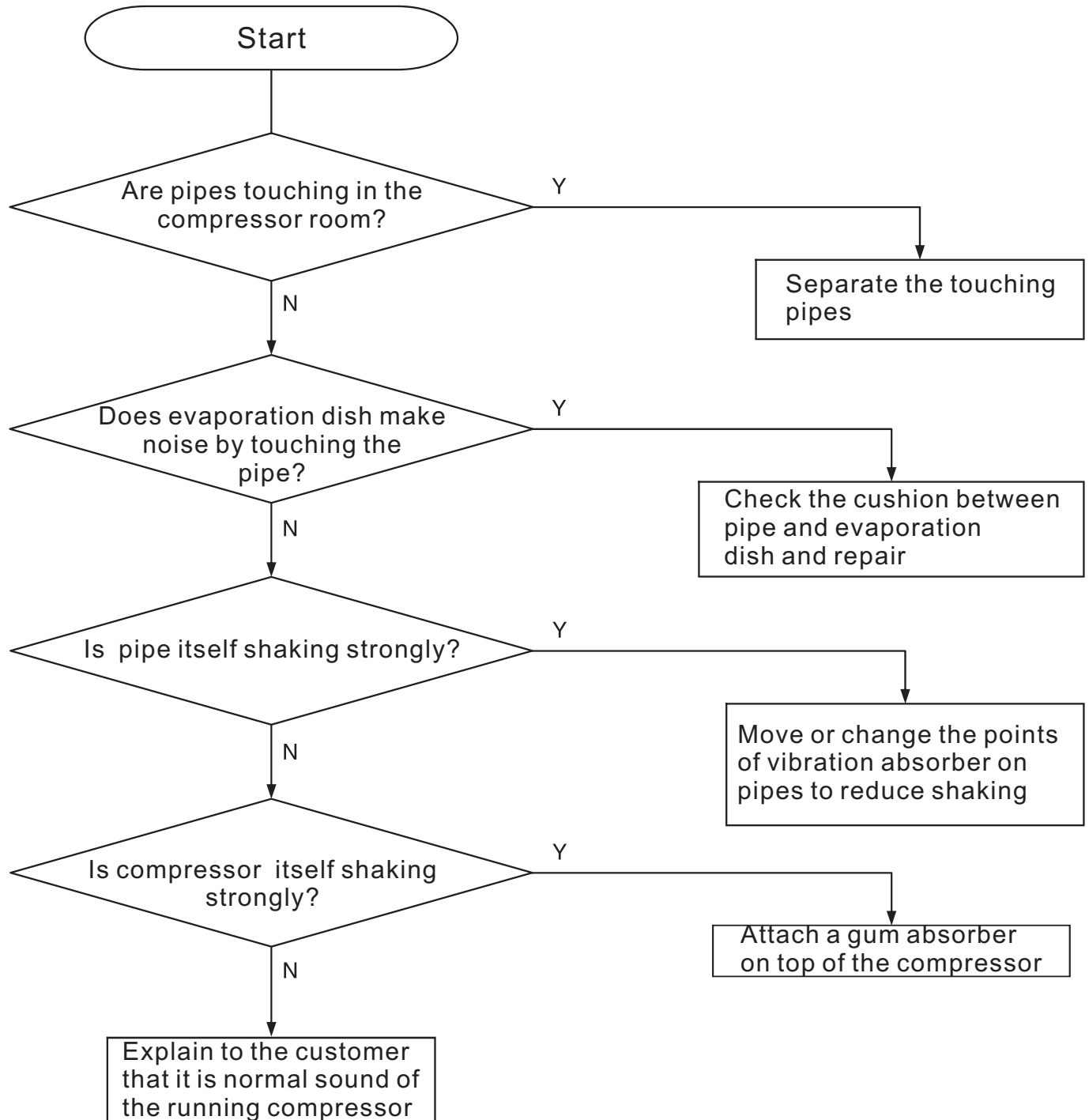

6.1 Circuit diagram

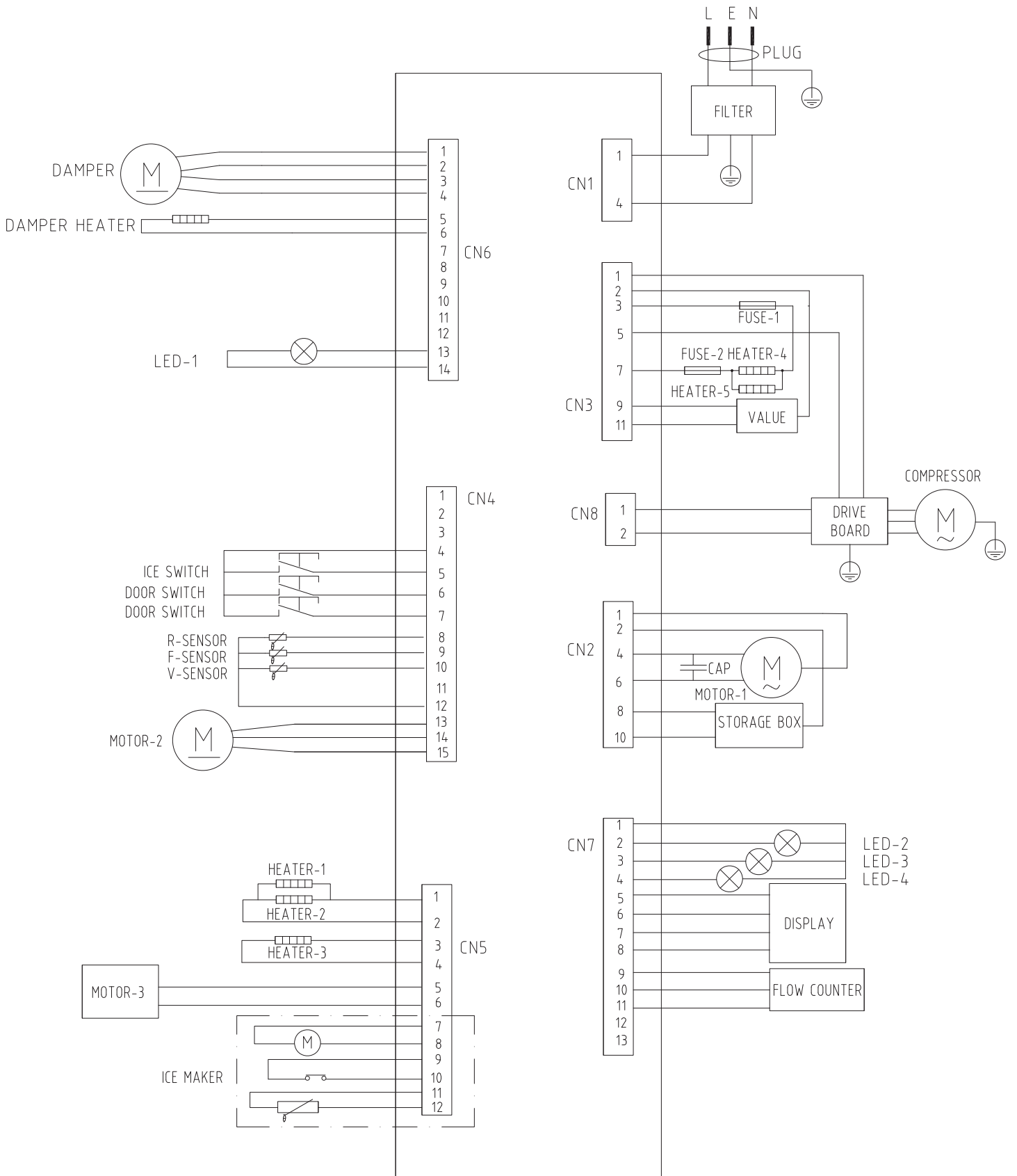

6.2 Mainboard

6.2.1 Checking method

If the problem is probably caused by the mainboard, change it directly to confirm.

6.2.2 Removing the mainboard

1. Unplug the appliance

2. Remove the screws of electric box cover by screwdriver, as picture 1.

3. Remove the electric box cover, as picture 2.

4. Unplug the terminals on the mainboard, as picture 3.

5. Pry up the mainboard by fingers and take it out, as picture 4.



Picture 1



Picture 2



Picture 3



Picture 4

6.3 Compressor

6.3.1 Basic parameters

Input voltage/frequency:220-240V/50Hz

Input power: $\leq 64.2 * 115\% W$

6.3.2 Checking method

- 1.Compressor will start 10 seconds after power-on,if it starts unsuccessfully,remove the electric box cover and check.
- 2.Check the connecting wiring between compressor and mainboard and repair if it is broken.
- 3.Use a multimeter to measure voltage between N label and COMP label on CN2 connector of mainboard,then measure frequency of CN8 connector.If the voltage equal to electric supply power and there is stabilized frequency,it means the compressor is broken,change it; If not,change the mainboard.

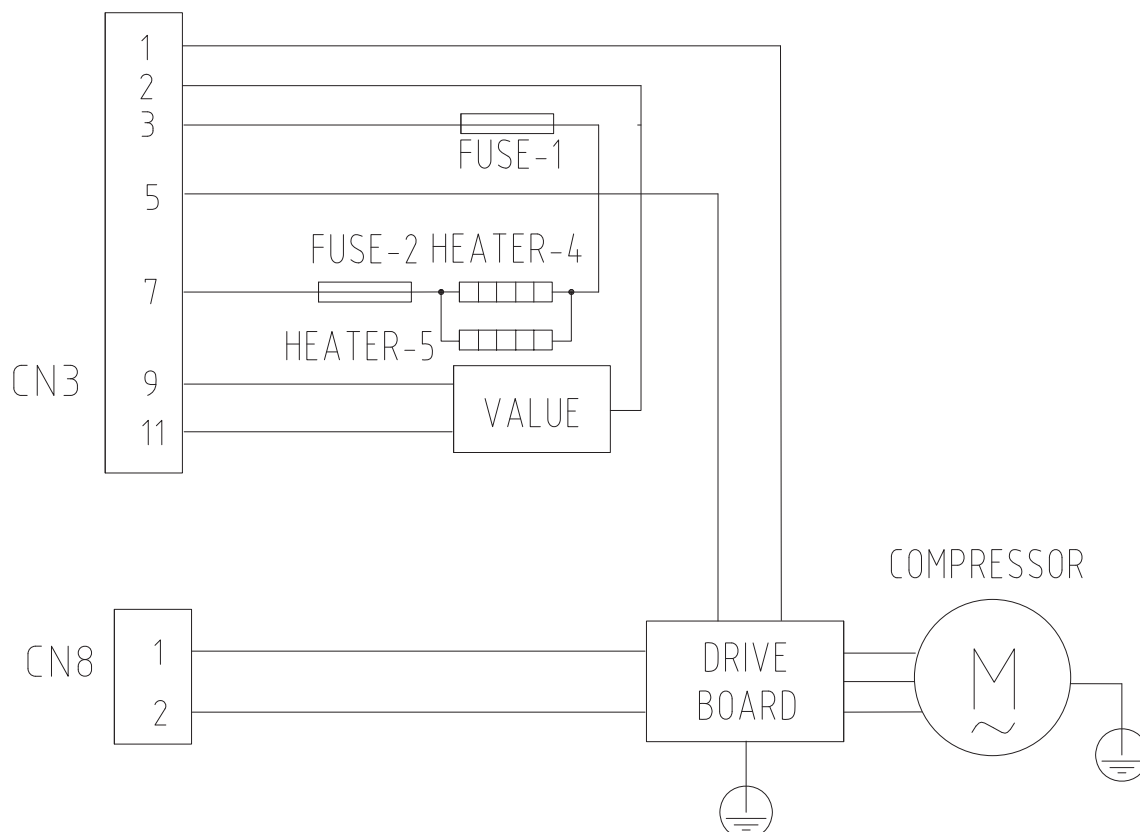

6.3.3 Removing the PTC starter and overload protector

- 1.Unplug the appliance
- 2.Remove the screws of protector box by screwdriver,as picture 1.
- 3.Pry up the protector box from top by screwdriver,as picture 2.
- 4.Unplug the overload protector,as picture 3.
- 5.Unplug the PTC starter,as picture 4.



Picture 1



Picture 2



Picture 3



Picture 4

6.4 Fan motor

6.4.1 Basic parameters

Rated voltage:DC12V

Rated input power:2.5W

6.4.2 Checking method

1.Check the connecting wiring of fan motor is well or not,repair if it is broken.The fan motor corresponding pin No.13~15 on CN4 connector of mainboard,as the drawing below.

2.Pin No.14 connect 12V power and pin No.13 connect GND,if the fan motor works normally,change the mainboard;If not,change the fan motor.

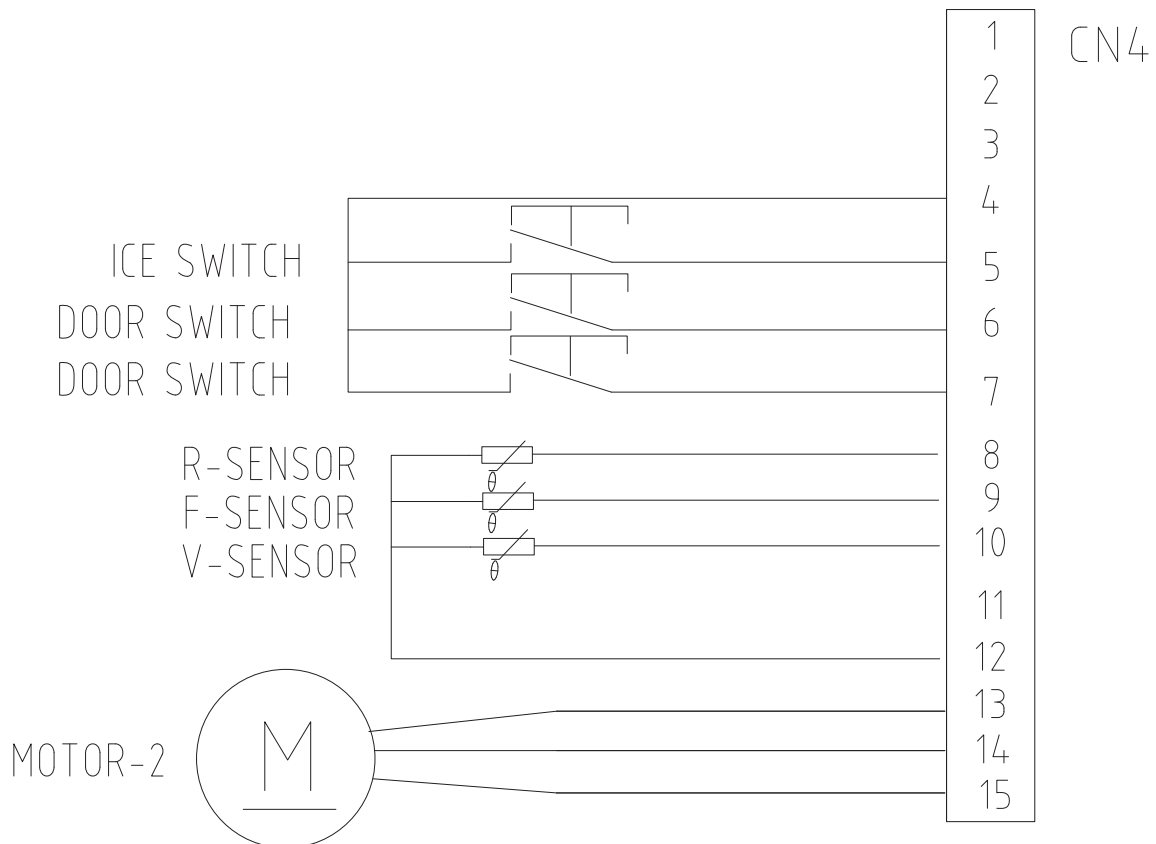

6.4.3 Removing the fan motor

- 1.Unplug the appliance
- 2.Remove the screws of freezer wind channel component by screwdriver,as picture 1.
- 3.Remove the wind channel component and unplug the terminals,as picture 2.
- 4.Remove the screw of the wind channel component by screwdriver, as picture 3.
- 5.Pry up the wind channel cover from the buckles by screwdriver,as picture 4.
- 6.Separate the front cover and back cover,as picture 5.
- 7.Remove the screws of fan motor and then remove the fan motor, as picture 6.



Picture1



Picture2



Picture3



Picture4



Picture5

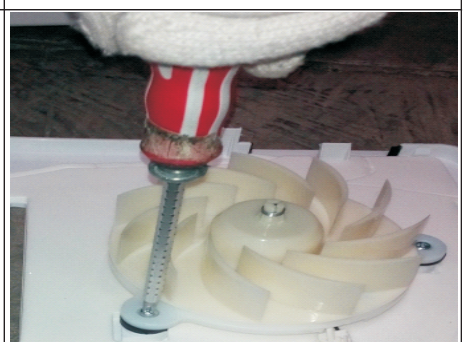

Picture6

6.5 Damper

6.5.1 Basic parameters

Rated voltage:DC12V

Rated current:60mA

6.5.2 Checking method

1.Check the connecting wiring of the damper is well or not,repair if it is broken.The damper corresponding pin No. 1~6 on CN6 connector of mainboard,as the drawing below.

2.The damper will turn on and off for one time after power-on,if not, change the mainboard first and change the damper if problem remains.

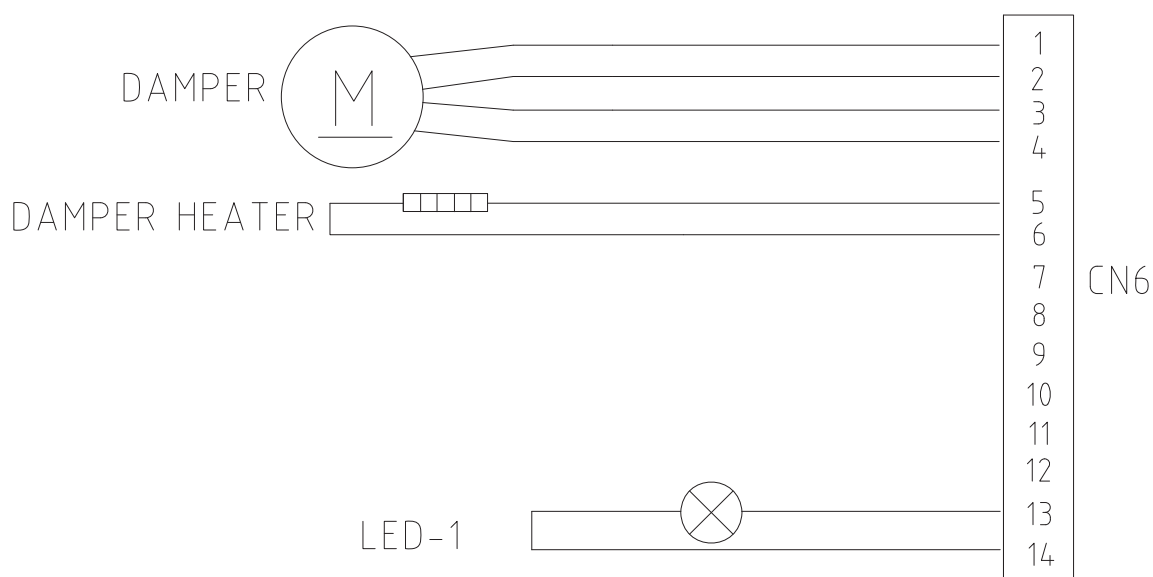

6.5.3 Removing the damper

- 1.Unplug the appliance
- 2.Remove the screws of refrigerator wind channel component by screwdriver,as picture 1.
- 3.Remove the wind channel component and unplug the terminals,as picture 2.
- 4.Separate the wind channel cover and foam,as picture 3.
- 5.Remove the sponge and adhesive paper on the foam,as picture 4.
- 6.Separate the upper foam and lower foam,as picture 5.
- 7.Remove the damper,as picture 6.



Picture1

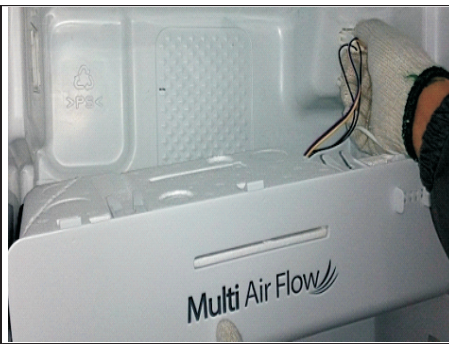

Picture2



Picture3



Picture4

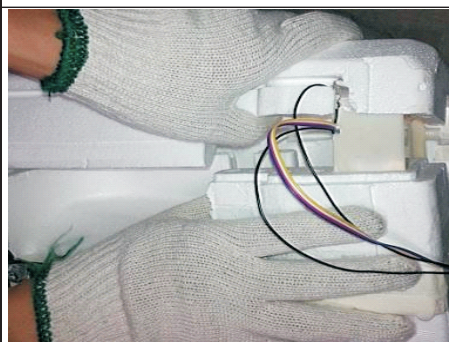

Picture5



Picture6

6.6 Light

6.6.1 Basic parameters

Rated voltage:DC12V

Rated power:2W

6.6.2 Checking method

1.Check the connecting wiring between light and mainboard is well or not,repair if it is broken.Refrigerator light corresponding pin No. 1 and No.2 on CN7 connector of mainboard,freezer light corresponding pin No.1 and No.3,ice maker light corresponding pin No.1 and No.4, as the drawing below.

2.Check output voltage corresponding light of the mainboard,if it is 12V,it means the mainboard is OK,change the light;If not,it means the mainboard is not OK,change it.

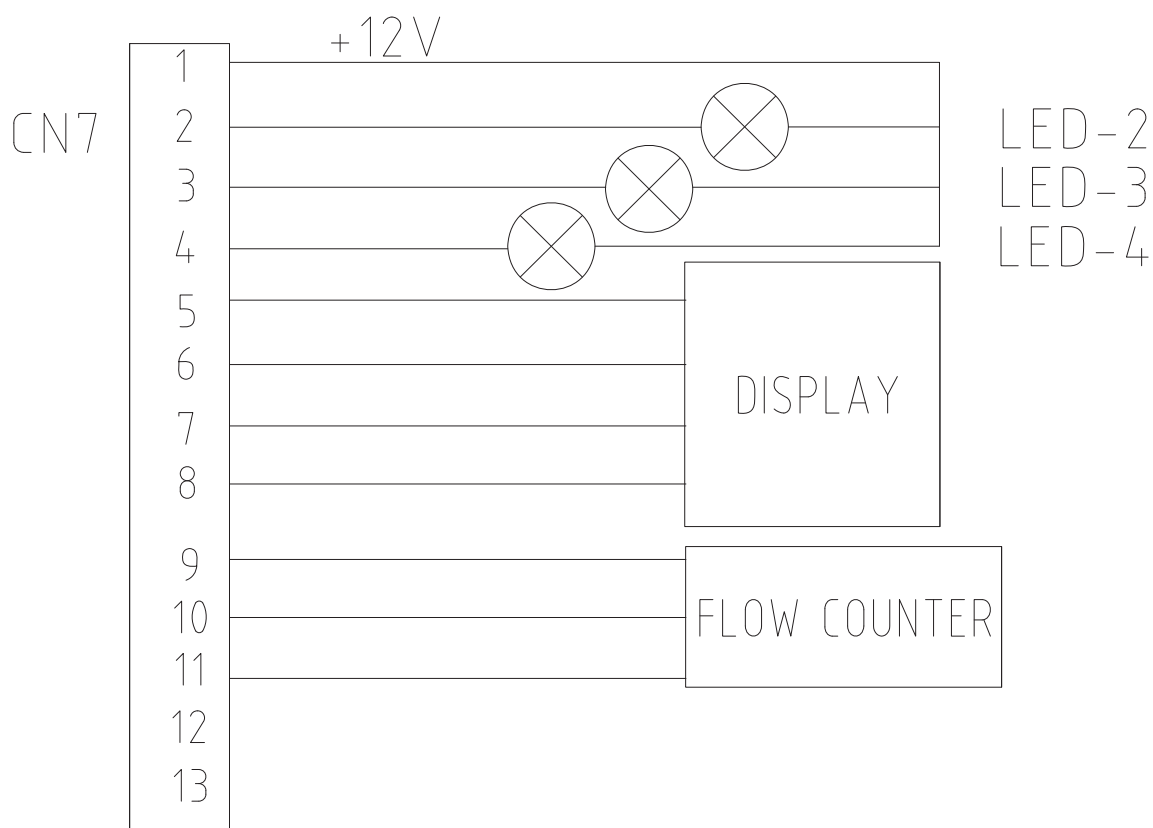

6.6.3 Removing the light

- 1.Unplug the appliance
- 2.Pry up the light cover from the buckles by screwdriver,as picture 1.
- 3.Remove the light cover,as picture 2.
- 4.Pry up the light from the buckles by screwdriver,as picture 3.
- 5.Unplug the terminal of the light,as picture 4.



Picture 1



Picture 2

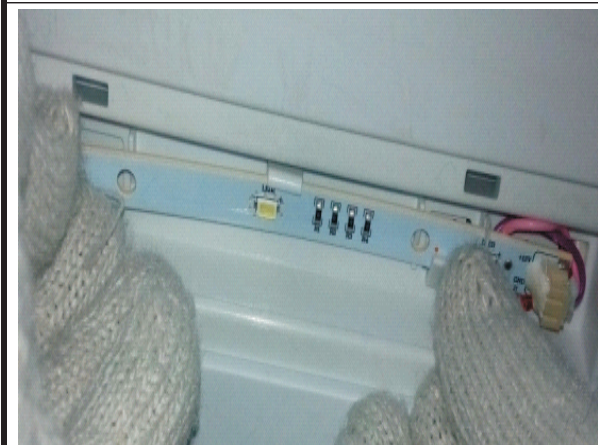

Picture 3

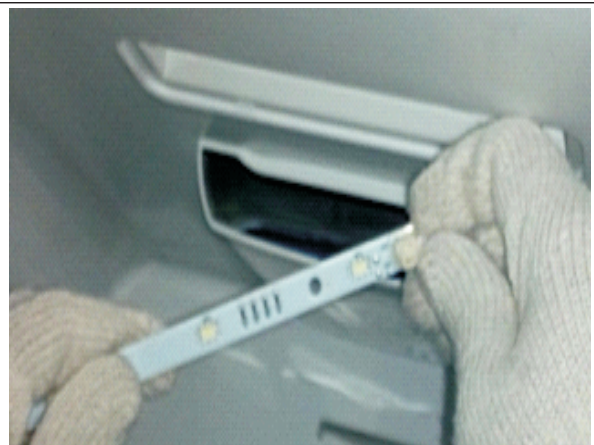

Picture 4

6.7 Door switch

6.7.1 Basic parameters

Load voltage:DC24V

Load current:0.05A

6.7.3 Checking method

1.Check the connecting wiring of door switch is well or not,repair if it is broken.Refrigerator door switch corresponding pin No.4 and No.6 on CN4 connector of mainboard,freezer door switch corresponding pin No.4 and No.7,as the drawing below.

2.Check the magnet on the door is dropped out or not.

3.Normally,when the door is closed,the two pins of door switch should be short circuit;When the door is open,the two pins should be open circuit.If the result is not abnormal,change the door switch.

4.If all above is OK,change the mainboard.

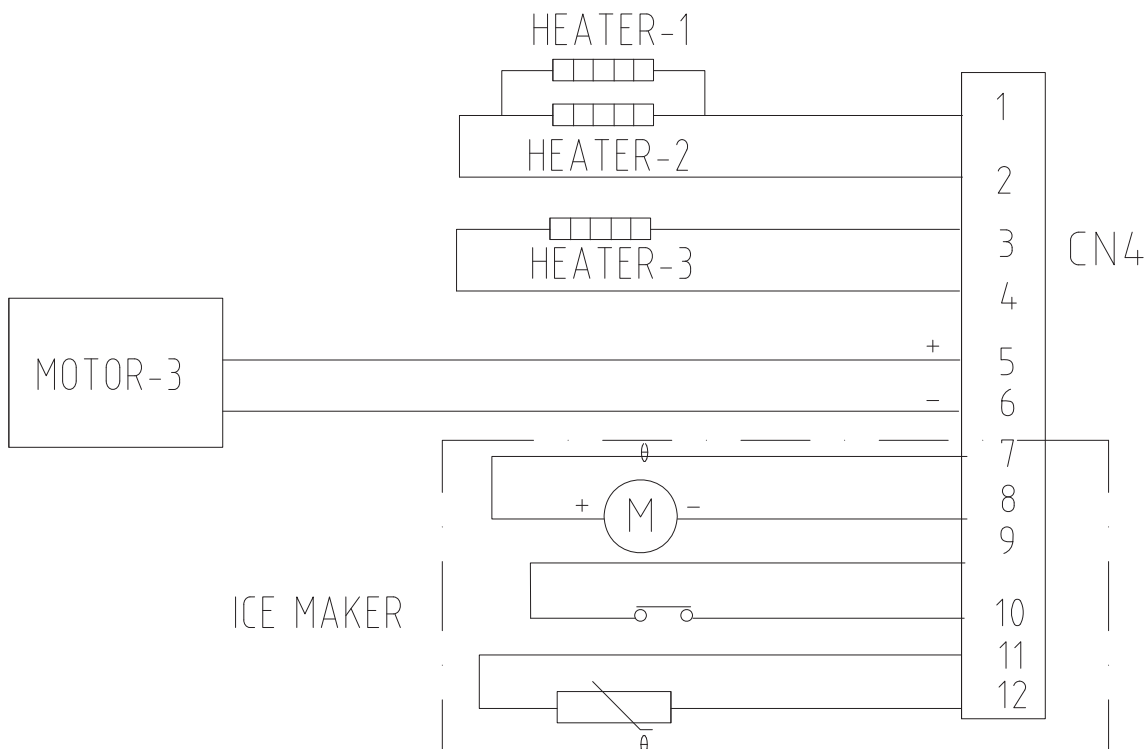

6.8 Temperature fuse

6.8.1 Basic parameters

Max fusing-off temperature:72°C

Load voltage:250V

Load current:10A

6.8.2 Checking method

Use a multimeter to measure resistance between the two terminals of the fuse,if it is open circuit,change the fuse.

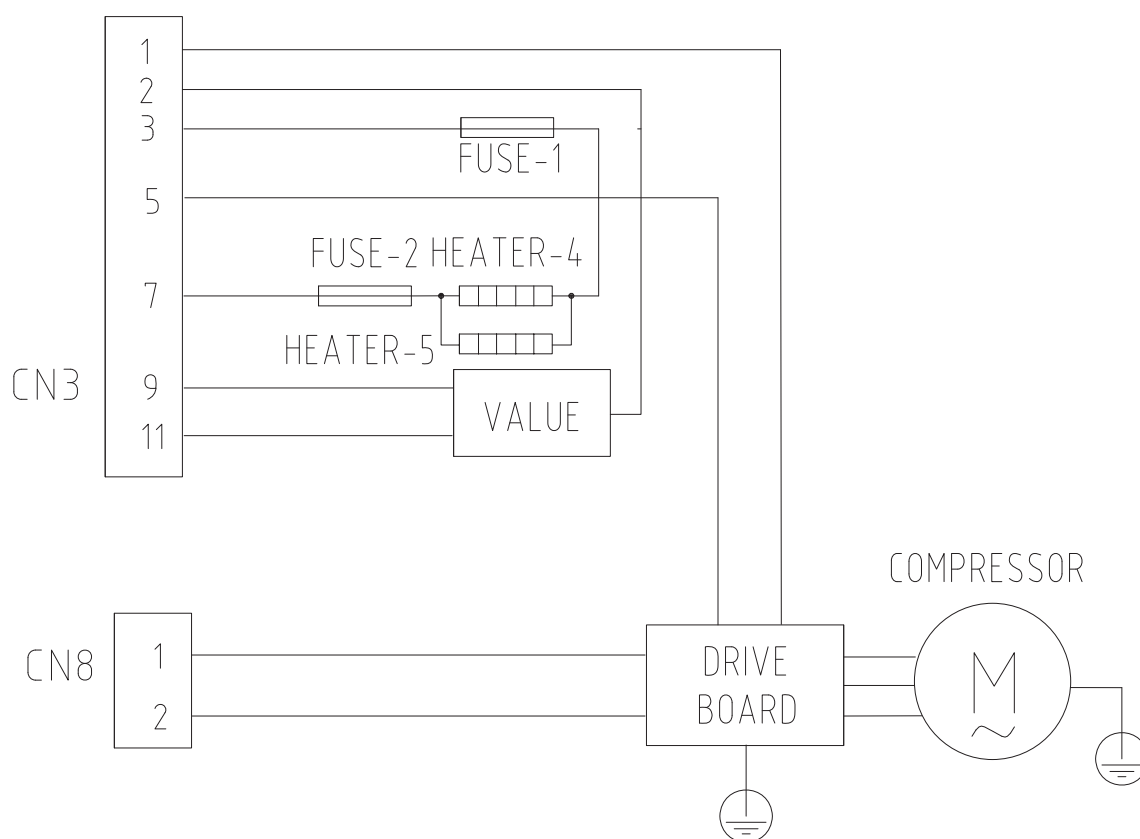

6.8.3 Removing the temperature fuse

- 1.After removing the freezer wind channel component,unplug the terminals,as picture 1.
- 2.Remove the screws of evaporator by screwdriver,as picture 2.
- 3.Separate the evaporator component from the cabinet and remove the foams at left side and right side,as picture 3.
- 4.Cut the self locking ties that fastening the temperature fuses by knife and then remove the fuses,as picture 4.



Picture 1

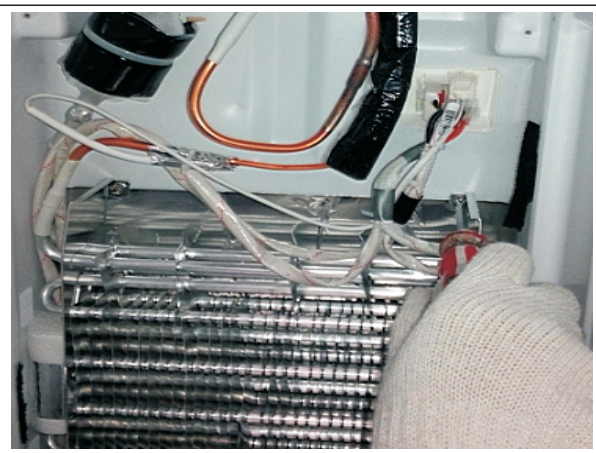

Picture 2



Picture 3

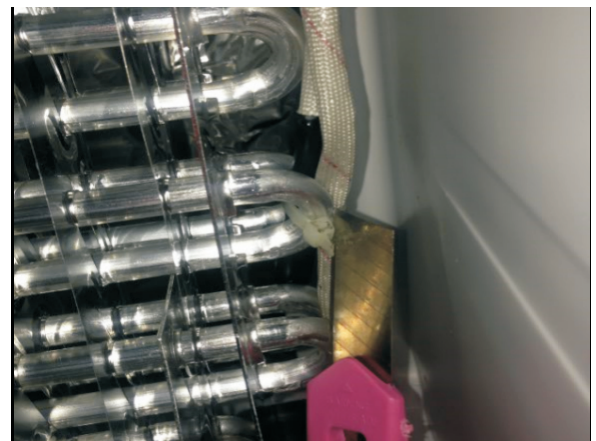

Picture 4

6.9 Defrost heater

6.9.1 Basic parameters

Rated voltage:AC220V

Rated power:220W

6.9.2 Checking method

- 1.Enter compulsory defrost mode,use a multimeter to measure the voltage between pin No.1 and No.9 on XP7 connector of the mainboard,if the voltage doesn't equal to electric supply power,it means the heater is broken,change it.
- 2.Check the fuse is well or not,refer to "6.8 Temperature fuse"chapter.
- 3.Use a multimeter to measure resistance of the heater,if the value isn't $220\ \Omega \pm 5\%$, it is broken,change the heater.

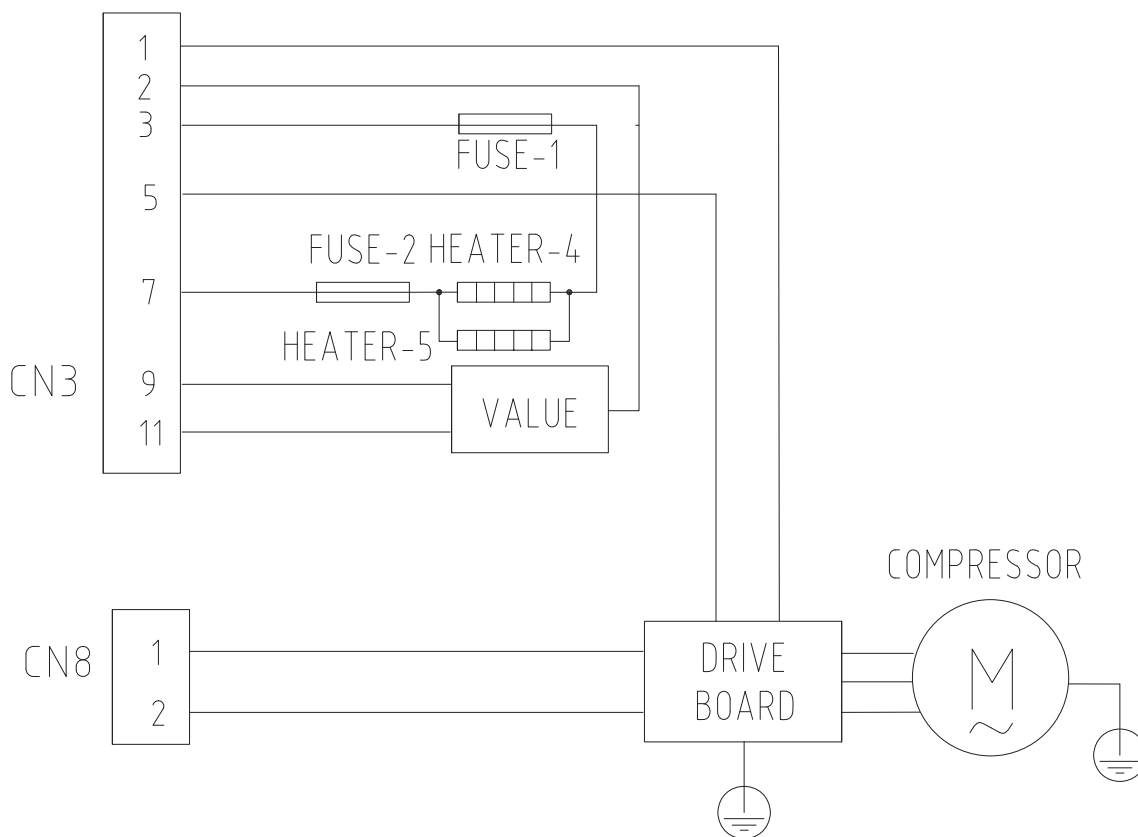

6.9.3 Removing the defrost heater

- 1.After removing the freezer wind channel component,unplug the terminals,as picture 1.
- 2.Remove the screws of evaporator by screwdriver,as picture 2.
- 3.Separate the evaporator component from the cabinet and remove the foams at left side and right side,as picture 3.
- 4.Cut the self locking ties that fastening the heater by knife,as picture 4.
- 5.Pry up the buckles that fastening the heater by screwdriver and then remove the heater,as picture 5.

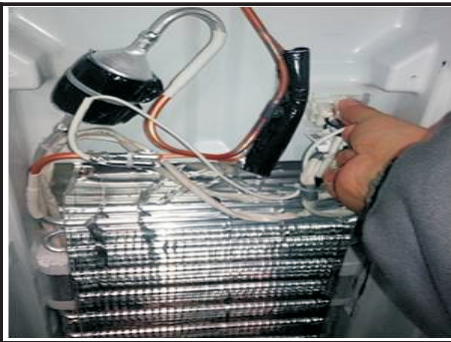

Picture1

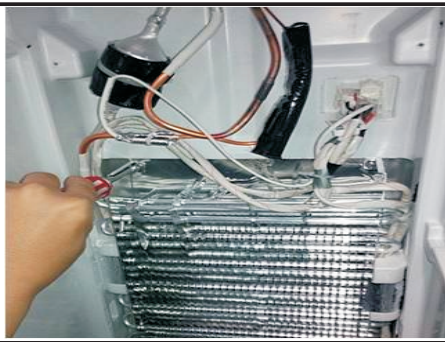

Picture2



Picture3

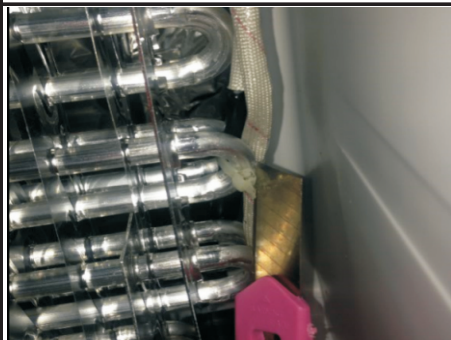

Picture4



Picture5

6.10 Ice maker

6.9.1 Checking method

Refer to “4.5 Error display” chapter.

6.9.2 Removing the ice maker

6.9.2.1 Removing the ice bucket

- 1.Raise the ice bucket up,as picture 1.
- 2.Pull the ice bucket slantingly downwards,as picture 2.
- 3.Pull the ice bucket out,as picture 3.



Picture1



Picture2



Picture3

6.9.2.2 Removing the water intake

- 1.Pull the front cover out slantingly upwards,as picture 1.
- 2.Pull the water intake slantingly upwards,as picture 2.
- 3.Remove the two buckles of the water intake,as picture 3.
- 4.Take out the water intake,as picture 4.



Picture 1



Picture 2



Picture 3



6.9.2.3 Removing the ice maker and holder

- 1.Remove the screws of the ice maker holder by screwdriver,as picture 1.
- 2.Unplug the terminal of the ice maker,as picture 2.
- 3.Remove the screws of the ice maker by screwdriver,as picture 3.
- 4.Remove the wiring,as picture 4.
- 5.Pull the ice maker upwards and remove it,as picture 5.

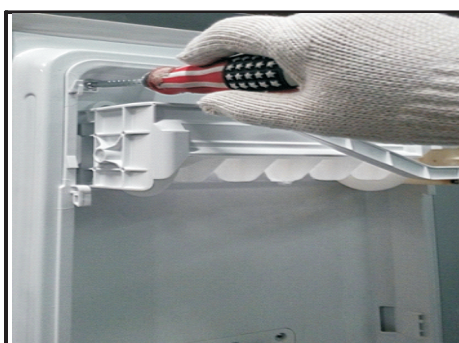

Picture1



Picture2



Picture3



Picture4



Picture5

6.9.2.4 Removing the ice crushing motor

- 1.Remove the screws of the motor by screwdriver,as picture 1.
- 2.Remove the coupling,as picture 2.
- 3.Remove the screws of the motor cover by screwdriver,as picture 3.
- 4.Remove the cover and pull out the motor and remove it,as pictire 4.



Picture1



Picture2



Picture3



Picture4

6.9.2.4 Removing the ice dispenser

- 1.Pull out the water tube,as picture 1.
- 2.Unplug connecting terminal,as picture 2.
- 3.Remove the screws by screwdriver,as picture 3.
- 4.Pry up the ice dispenser at the buckles,as picture 4.
- 5.Pull out the ice dispenser,as picture 5.
- 6.Unplug the motor terminal and remove the ice dispenser,as picture6.



Picture1



Picture2



Picture3



Picture4



Picture5



Picture6

6.9.2.4 Removing the water valve

- 1.Remove the screws of the water valve by screwdriver,as picture 1.
- 2.Pull out the water valve,as picture 2.
- 3.Unplug the connecting terminal,as picture 3.
- 4.Remove the water tube connector,as picture 4.
- 5.Remove the water tube,as picture 5.
- 6.Pull out the water valve,as picture 6.

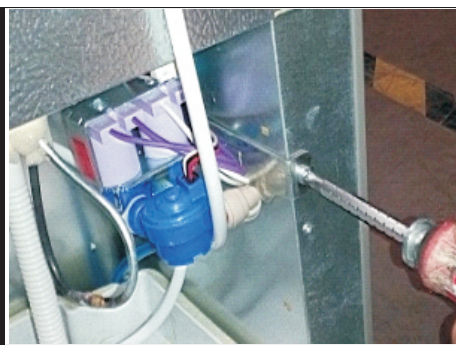

Picture1

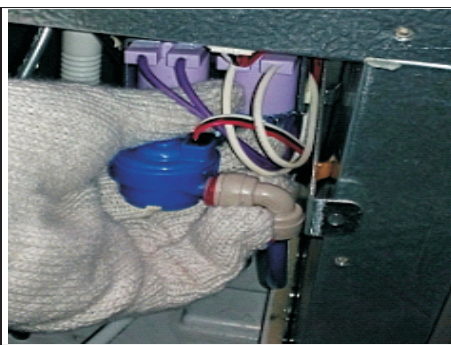

Picture2



Picture3

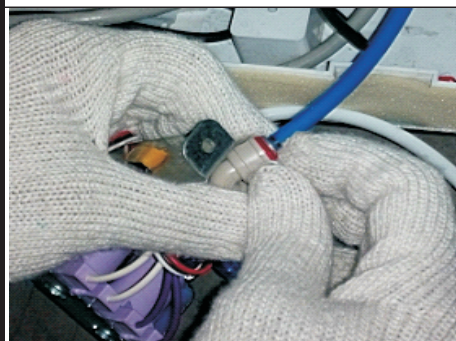

Picture4



Picture5

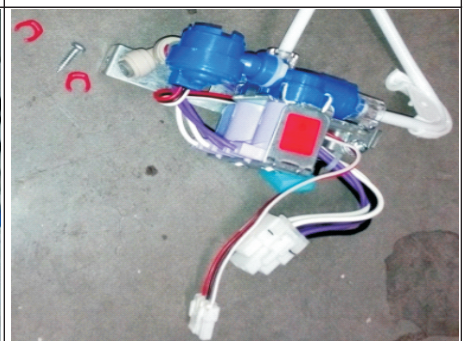

Picture6

7.1 Refrigeration system

The refrigerator system is single cycle wind cooling system:

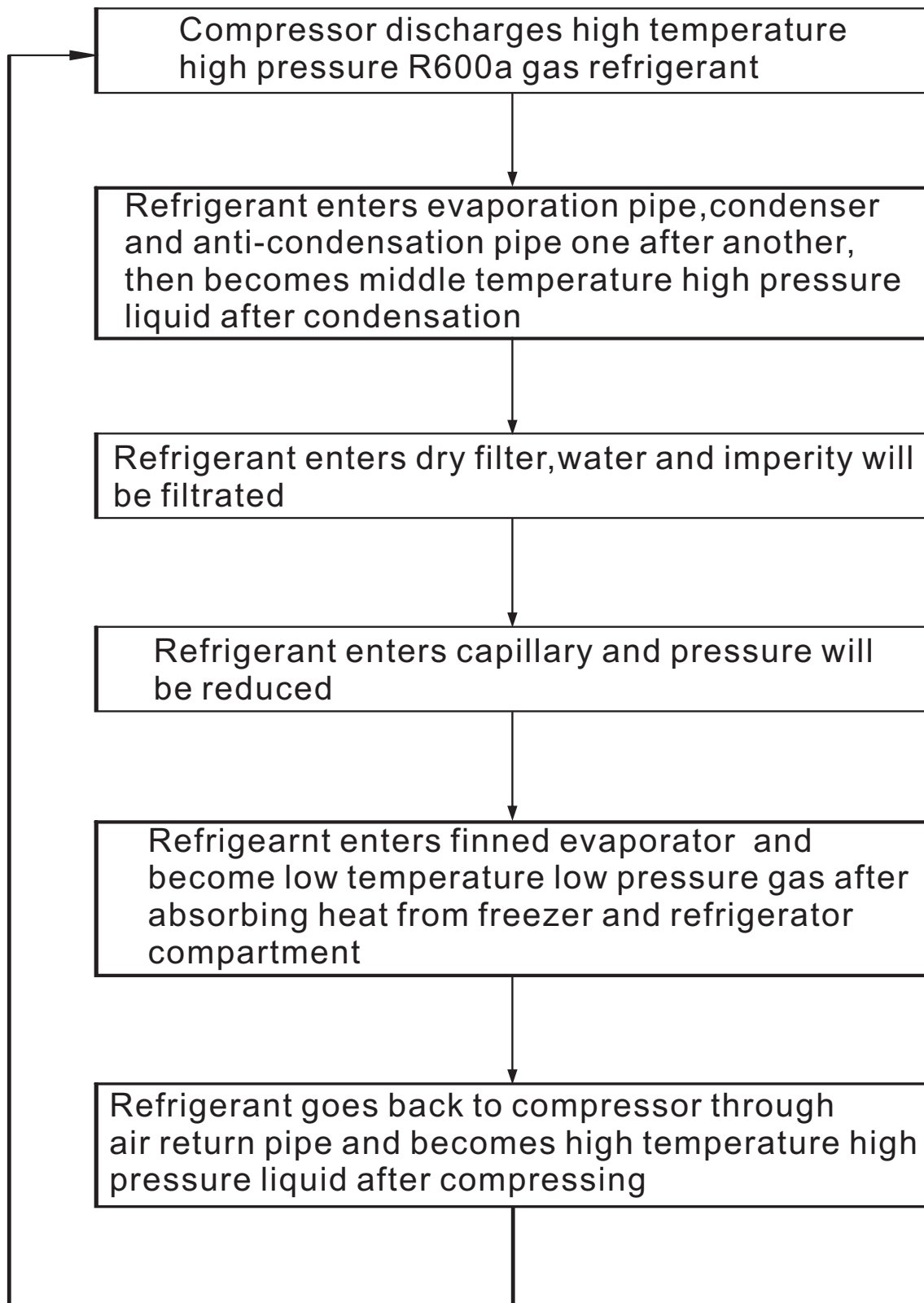

7.1 Refrigeration system

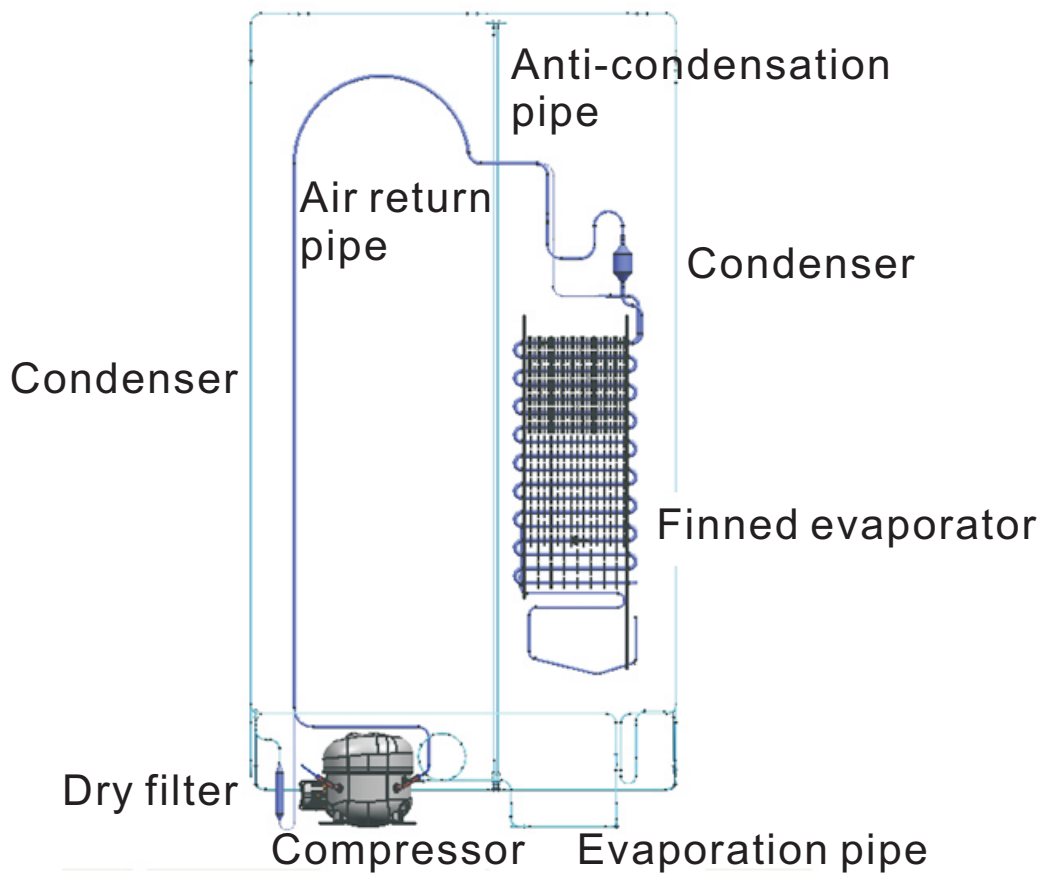

7.2 Summary of repair

Process	Contents	Tools
Remove refrigerant Residuals	* Cut charging pipe ends (Comp. & Dryer) and discharge refrigerant from drier and compressor.	* Nipper, side cutters
Parts replacement and welding	* Confirm refrigerant (R-134a or R-600a) and oil for compressor and drier. * Confirm N2 sealing and packing conditions before use. Use good one for welding and assembly. * Repair in a clean and dry place.	* Pipe Cutter, Gas welder, N2 gas
Vacuum	* Evacuate for more than forty minutes after connecting manifold gauge hose and vacuum pump to high (drier) and low (compressor) pressure sides.	* Vacuum pump, Manifold gauge.
Refrigerant charging and charging inlet welding	* Weigh and control the bombe in a vacuum conditions with electronic scales and charge through compressor inlet (Process tube). * Charge while refrigerator operates). * Weld carefully after inlet pinching.	* Bombe (mass cylinder), refrigerant manifold gauge, electronic scales, punching off flier, gas welding machine
Check refrigerant leak and cooling capacity	* Check leak at weld joints. Note :Do not use soapy water for check. * Check cooling capacity → Check condenser manually to see if warm. → Check hot pipe manually to see if warm. → Check frost formation on the whole surface of the evaporator.	* Electronic Leak Detector, Driver.
Compressor compartment and tools arrangement	* Remove flux from the silver weld joints with soft brusher wet rag. (Flux may be the cause of corrosion and leaks.) *Clean tools and store them in a clean tool box or in their place.	* Copper brush, Rag, Tool box
Transportation and installation	* Installation should be conducted in accordance with the standard installation procedure. (Leave space of more than 5 cm from the wall for compressor compartment cooling fan mounted model.)	

7.3 Regulation for repair

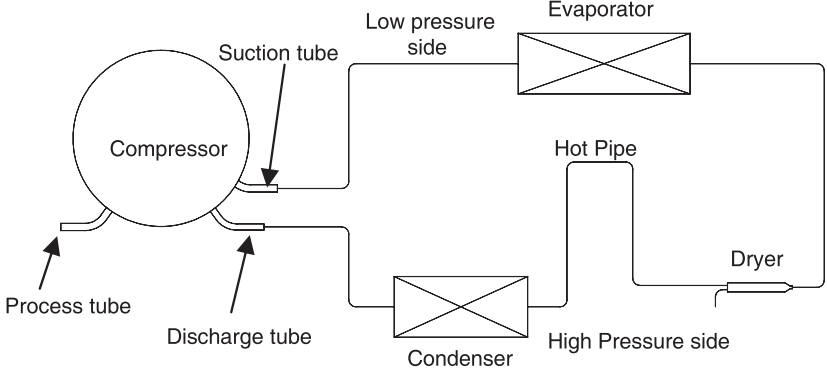
Items	Precautions
Use of tools.	1) Use special parts and tools for R-134a or R-600a
Removal of retained refrigerant.	<p>1) Remove retained refrigerant more than 5 minutes after turning off a refrigerator. (If not, oil will leak inside.)</p> <p>2) Remove retained refrigerant by cutting first high pressure side (drier part) with a nipper and then cut low pressure side. (If the order is not observed, oil leak will happen.)</p> 
Replacement of drier.	1) Be sure to replace drier when repairing pipes and injecting refrigerant.
Nitrogen blowing welding.	1) Weld under nitrogen atmosphere in order to prevent oxidation inside a pipe. (Nitrogen pressure : 0.1~0.2 kg/cm2.)
Others.	<p>1) Nitrogen only should be used when cleaning inside of cycle pipes inside and sealing.</p> <p>2) Check leakage with an electronic leakage tester.</p> <p>3) Be sure to use a pipe cutter when cutting pipes.</p> <p>4) Be careful not the water let intrude into the inside of the cycle.</p>

7.4 Practical work for repair

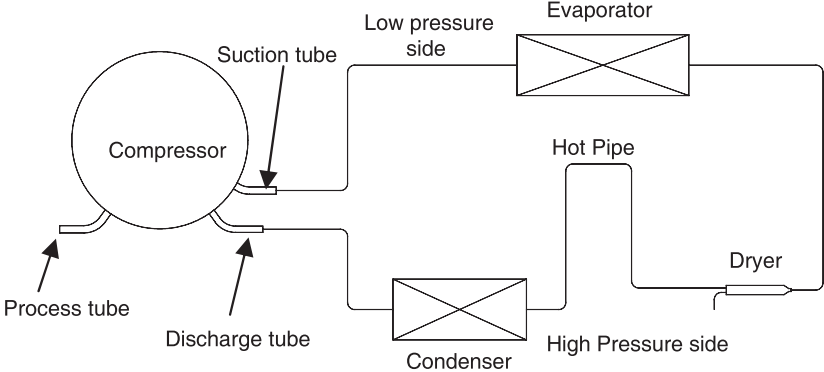
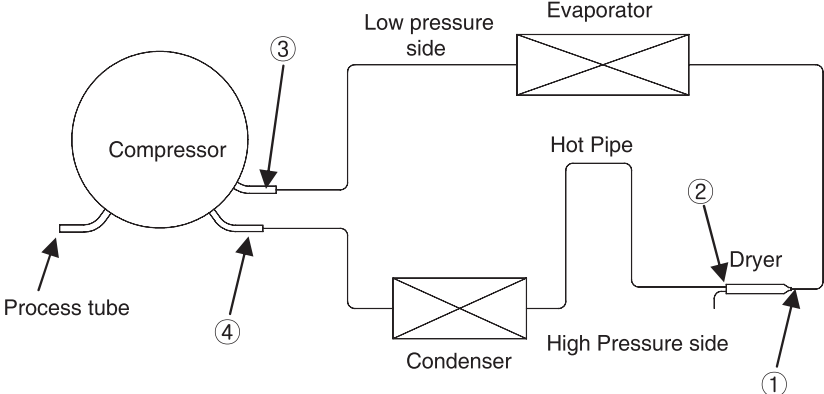
Items	Precautions
<p>1. Removal of residual refrigerant.</p>	<p>1) Remove residual refrigerant more than 5 minutes later after turning off the refrigerator. (If not, compressor oil may leak inside.) 2) Remove retained refrigerant slowly by cutting first high pressure side (drier part) with a nipper and then cut low pressure side.</p> 
<p>2. Nitrogen blowing welding.</p>	 <p>* When replacing a drier: Weld 1 and 2 parts by blowing nitrogen (0.1~0.2kg/cm²) to high pressure side after assembling a drier.</p> <p>* When replacing a compressor: Weld 3 and 4 parts by blowing nitrogen to the low pressure side. Note) For other parts, nitrogen blowing is not necessary because it does not produce oxidized scales inside pipe because of its short welding time.</p> <p>- KEYPOINTING Welding without nitrogen blowing produces oxidized scales inside a pipe, Which affect on performance and reliability of a product.</p>

7.4 Practical work for repair

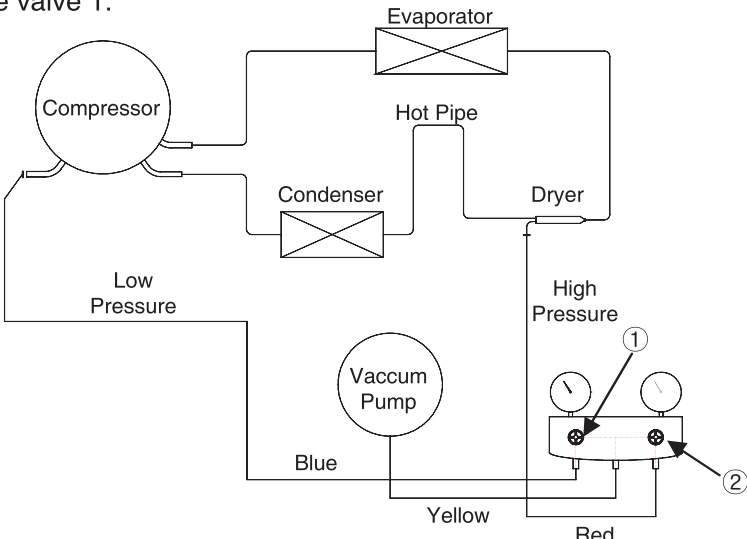
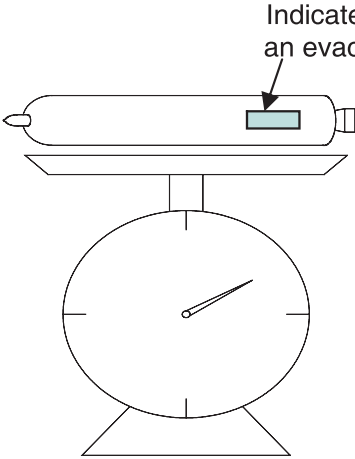
Items	Precautions
3.Vacuum degassing.	<p>* Pipe Connection Connect a red hose to the high pressure side and a blue hose to the low pressure side.</p> <p>* Vacuum Sequence Open 1,2 valves and evacuate for 40 minutes. Close valve 1.</p>  <p>※ KEYPOINTING</p> <ol style="list-style-type: none"> 1) If power is applied during vacuum degassing, vacuum degassing shall be more effective. 2) Operate compressor while charging refrigerant. (It is easier and more certain to do like this.)
4.Refrigerant charging.	<p>* Charging sequence</p> <ol style="list-style-type: none"> 1) Check the amount of refrigerant supplied to each model after completing vacuum degassing. 2) Evacuate bombe with a vacuum pump. 3) Measure the amount of refrigerant charged. <ul style="list-style-type: none"> - Measure the weight of an evacuated bombe with an electronic scale. - Charge refrigerant into a bombe and measure the weight. Calculate the weight of refrigerant charged into the bombe by subtracting the weight of an evacuated bombe.  <p>- KEYPOINTING</p> <ol style="list-style-type: none"> 1) Be sure to charge the refrigerant at around 25C. 2) Be sure to keep -5g in the winter and +5g in summer. <p>Calculation of amount of refrigerant charged</p> <p>the amount of refrigerant charged = a weight after charging - a weight before charging (a weight of an evacuated cylinder)</p>

7.5 Brazing reference drawing

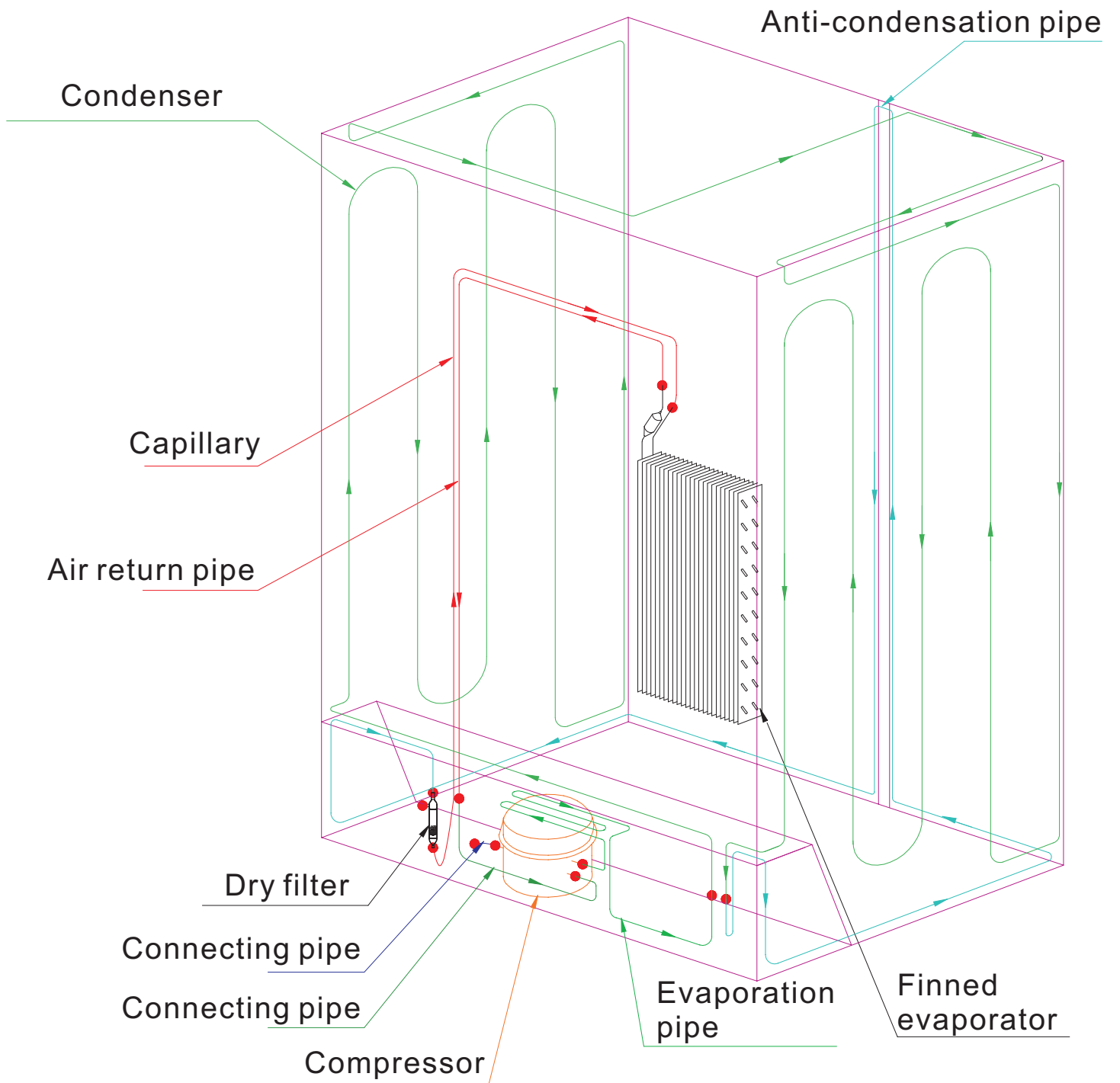

- Refrigerant flowing direction
- Welding points