

UNIVERSAL TECHNICAL INSTITUTE, INC.

Emergency Management Plan Appendix – Exton

750 Pennsylvania Drive
Exton, PA 19341

Phone: 610-458-5595
Fax: 610-646-8349
Toll Free: 877-884-3986

Appendix A

Emergency Management Team Contacts	
<i>TITLE</i>	<i>PHONE NUMBER</i>
Campus President	610-646-8301
Director of Education/ Operations	610-646-8651
Facilities Director	610-646-8552
Student Services Director	610-646-8756

Appendix B

Community Emergency Contacts		
Emergency	9-1-1	
Non-Emergency Police Department	610-458-5862	Upper Uwchlan Township
Non-Emergency Fire Department	610-363-7663	Lionville Fire Co.
PECO [Electric]	800-841-4141	Acct # 88372-00906
PECO [Gas]	800-841-4141	Acct # 60533-00901
Aqua PA [Water & Utilities]	877-987-2782	Acct# 0004894210405646
County Health Department	610-344-6225	
Hospital – Chester County	610-431-5000	
Urgent Care – Premier Urgent Care – Tower Health	610-561-6320	
OSHA	800-321-6742	www.osha.gov
EPA Spills and Emergencies	404-562-8700	
EPA State Agency – Pennsylvania	800-438-2474	
Safety Data Sheets	888-362-7416	msdsonline.com
Poison Control Center	800-222-1222	www.aapcc.org
Center for Disease Control	800-232-4636	www.cdc.gov
Homeland Security	202-202-8000	www.dhs.gov
Additional Support		
Property Management	800-972-2739	W.P. Carey
UTI – IT Service Desk	866-435-7619	Service Desk
Transportation Company Krapf	484-318-8417	Ted Dinsmore
Alarm Monitoring Company	610-903-4900	Protection Bureau
Security Contractors	610-903-4900	Alarm Acct Code: 2290 Fire Acct Code: 2050

When necessary, the Facilities Manager and/or their designee(s) are responsible for outreach to governmental or other emergency agencies.

EMERGENCY RESPONSE NOTIFICATION INFORMATION

(To be provided to local and State emergency response agencies):

Location of incident	Time of incident
Type of incident	Danger present
Type of hazardous material involved	Action undertaken
Injuries	

Appendix C

Communication and Notification

PA system

UTI Exton utilizes a building-wide public address (PA) system to provide general announcements and critical information in times of emergencies.

Everbridge Mass Notification system

UTI utilizes Everbridge Mass Notification system; this comprehensive notification system enables us to send notifications to administration, employees and students; keeping everyone informed before, during, and after events whether emergency or non-emergency.



All employee PC Desktops are equipped with an SOS Button for added security measures. In the event of an emergency, click on the SOS Button on your desktop and choose either the HELP Button or the SOS Button. You can type a message and click send or click send to transmit.



Silent Alarm/Panic Switch 10 designated switches are located throughout Administration and Education Offices. These buttons notify the Protection Bureau when pressed who alert the police.



Door Lock/Panic Switch located at main Reception Desk, Campus Presidents desk and Education coordinators desk. Locks all entry/exit doors when activated. These buttons will lock all external doors when activated.

Appendix D

Emergency Evacuation Procedures

In the event of Fire/Fire Alarm, we will evacuate the building for the safety of staff and students.

Step One: Fire Alarm activation.

Step Two: Proceed to your designated rally point (walk do not run) located on the North side of the parking lot and the west side lower diesel parking lot. Rally point locations are based on location in the building and are posted in each room as a map showing the rally point for that room.

Step Three: Accountability – Instructors; Please bring your role sheets to conduct a head count. Make sure your class stays with you, and you always stay with them. Leaders: Please do a head count of your team and stay with them until the event is over. Guests/Visitors to be escorted out and accounted for by team member responsible for that group.

Step Four: Fire Alarm deactivation.

Step Five: Wait for “All Clear” announcement before returning inside facility.

All are to stay clear of the building and adjacent roadways to allow unimpeded access to the Emergency Services.

Smoking is NOT PERMITTED.

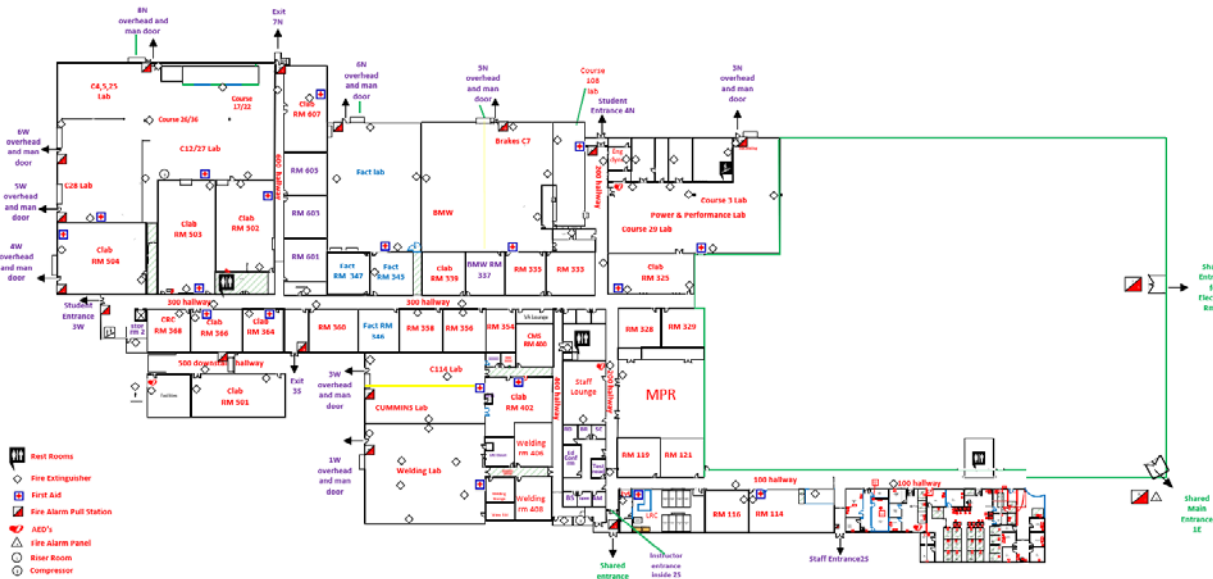

Appendix E

Safety Data Sheets

The Hazard Communication Standard (HCS) requires chemical manufacturers, distributors, or importers to provide Safety Data Sheets (SDSs) (formerly known as Material Safety Data Sheets or MSDSs) to communicate the hazards of hazardous chemical products and guidelines for safe handling and storage. Staff and students have online access to SDS information for products in use in labs and throughout the facility.

SDS - SAFETY DATA SHEETS

MSDSONLINE.COM

FOR ONLINE ACCESS TO SDS INFORMATION



Click the MSDSonline shortcut icon on any UTI Desktop or Laptop

or Employees can click the Link on the People Safety Page on Inside Track



TO HAVE AN SDS FAXED TO YOU

Contact MSDSonline 24 hours/day, 7 days/week

1-888-362-7416

PROVIDE:

- Product Name – Manufacturer - Your Fax Number
- Product Code [optional]



MSDSonline
— a safety solution —

Standardized information includes the following:

Section 1, Identification includes product identifier; manufacturer or distributor name, address, phone number; emergency phone number; recommended use; restrictions on use.

Section 2, Hazard(s) identification includes all hazards regarding the chemical; required label elements.

Section 3, Composition/information on ingredients includes information on chemical ingredients.

Section 4, First-aid measures includes important symptoms/effects, acute, delayed; required treatment.

Section 5, Fire-fighting measures lists suitable extinguishing techniques, equipment; chemical hazards from fire.

Section 6, Accidental release measures lists emergency procedures; PPE; proper methods of containment/cleanup.

Section 7, Handling and storage lists precautions for safe handling and storage, including incompatibilities.

Section 8, Exposure controls/personal protection lists OSHA's Permissible Exposure Limits (PELs); ACGIH Threshold Limit Values (TLVs); and any other exposure limit used or recommended by the chemical manufacturer, importer, or employer preparing the SDS where available as well as appropriate engineering controls; personal protective equipment (PPE).

Section 9, Physical and chemical properties lists the chemical's characteristics.

Section 10, Stability and reactivity lists chemical stability and possibility of hazardous reactions.

Section 11, Toxicological information includes routes of exposure; related symptoms, acute and chronic effects; numerical measures of toxicity.

Section 12, Ecological information* Section 13, Disposal considerations*Section 14, Transport information* Section 15, Regulatory information* **Section 16, Other information**, includes the date of preparation or last revision.

Appendix F

Inclement Weather Response

Floods/Hurricanes

Use extreme caution around any electrical appliance or outlet near any leak or water.

Take only essential steps to avoid or reduce immediate water damage, such as covering objects with plastic sheeting or moving small or light objects out of danger.

If it is safe to do so, secure vital equipment, records, and hazardous materials, and shut off all non-essential electric equipment.

If there is any potential for danger if you remain inside the building, or if otherwise instructed, evacuate the area.

If it is safer to remain inside the building, shelter in place.

If instructed to shelter in place, move to rooms of the building without windows if possible.

Do not leave the building or area under any circumstances until you have been cleared to do so by the Campus President or their designee.

Once out of the building or area, do not reenter under any circumstances until it has been cleared for reentry by the EMT or Campus President.

Snow / Ice Storms

When weather conditions exist such that there is an actual or predicted snow and/or ice, the Campus President or their designee will evaluate the conditions of the roads and walkways, among other things, and decide whether to release early, postpone or cancel classes or any other activity due to the weather.

The Campus President or their designee will communicate any cancellations or postponements through Everbridge, UTI.edu and local media outlets.

Facilities will work to ensure the snow and/or ice has been removed or addressed and take other appropriate steps to prepare the location for safe travel on the campus.

Tornado/Severe Weather

During a weather watch, conditions will be monitored, and the campus community will be kept informed through PA announcement and/or Everbridge notifications. If conditions change from a watch to a **Tornado Warning**, staff, students and visitors need to be prepared to follow the severe weather procedures. Move to interior rooms, away from glass windows and doors, secure in place and cover head and neck from potential debris.

Once in location, cover your head to protect against flying debris and glass. Assist those who are in need of additional assistance. Do not seek shelter in large lab areas. Remain calm so you can hear verbal instructions. Report all injuries immediately. DO NOT leave the facility until the storms have passed and an "All Clear" message has been communicated. Once an "All Clear" message has been given to exit the building, be aware of down power lines, debris and broken glass. Do not re-enter the building unless the Campus President or their designee

has given approval. Follow instructions provided by emergency workers, law enforcement officials, or the Campus President or their designee. This may include roll call or head counts.

Appendix G

Building Access

UTI Exton utilizes an Access Control System to secure the property and maximize the safety of the staff, students and visitors. Employees with Alarm Access will be granted 24/7 Access Cards. All other employees will be granted Access Cards from 5:45am to 11:00pm Monday through Friday.

Normal Operating Schedule is as follows:

Student Entrances on West and North ends of the building

Door Schedules		
Front lobby	Student Entrance 4N and 3W Auto/diesel classes	Student Entrance 4N and 3W - MSAT, R&A, Welding Student Card access only
8 am- 5pm	7:00 AM to 8AM	6AM-6:40AM, 9AM-9:40AM, 11:30AM-12:10PM, 3PM-4:10PM, 5PM-6PM, 7:30-8:30PM
	11:30 AM to 12:10 PM	

Outside of the scheduled hours, students will request entry by using the Video Door Station located at the 4N and 3W student entrances. Master Station with Display Screen is located at the front desk (primary) and the LRC (back up). Access times and control system utilization is subject to change.

Appendix H

ALICE Protocols

UTI has adopted the following strategy for Active Shooter/Violent Intruder and Terrorism Response known as **ALICE**. **ALICE** is an acronym for **Alert, Lockdown, Inform, Counter** and **Evacuate**. Prior to **ALICE**, lockdown procedures utilized for higher education involved the staff locking their doors, moving the students to a part of the room where they could not be seen, and quietly remaining there until an “all clear” announcement was given. This passive response plan was predicated on exterior threats and was never meant or developed for interior threats or people in contact with threats.

The **ALICE** plan offers a different philosophy considering lessons learned over the past twenty-five years. The philosophy of **ALICE** is to use technology and information in a way so that faculty, staff and students can make informed decisions in a crisis, evacuate if possible from the danger zone, and provide realistic training so that those involved in a crisis have a better chance of surviving.

Please familiarize yourself with the **ALICE** program detailed in the summary below

The **ALICE** program is designed to give a person, or group of people, who may find themselves in a violent, life threatening situation, some mental and physical tools that could play a vital role in their survival. The program is designed so that anyone can employ the strategies. Young, old, male, female, it does not matter. One does not have to be police or military trained in order to survive a violent encounter. He or she does need to have a frame of reference from which to draw, when making life saving decisions under extreme pressure, much like preparing for a fire, tornado or earthquake. **ALICE** is an acronym for:

ALERT, notify authorities and those in harm’s way of the danger at hand. It is important to be as clear and

accurate with the information as possible. Remember to identify yourself, your location, the suspect information, type of weapon, direction of travel and a call back number. Do not hang up unless your safety is compromised or you are directed to by the dispatcher.

LOCKDOWN, or shelter in place. By locking down and barricading entry points, you are making yourself a hard target and creating a stronghold that nobody should be able to enter. Only police personnel may enter a locked down room.

INFORM, give real-time updates. This can be accomplished with things such as video surveillance equipment or public address systems. Updates during a violent intruder incident allow you to make sound decisions about how to react and what steps, if any, to take next. They can also act as good distractors for the intruder.

COUNTER the attacker as a last resort. There have been instances where victims did not have the ability to lockdown or get out because the violent incident occurred right next to them or they were in an area that was not securable. There is also the possibility of the intruder breaching a secured area. If this is the situation then total commitment to countering the attacker is essential. Many objects can be used as distraction devices, spread out, turn out the lights and be ready to cause confusion for the intruder and make yourself a hard target.

EVACUATE, or get out! Your goal here is to put as much time and distance as possible between you and the attacker. Do not use the same rally point as with a fire or earthquake drill, you will want to move much further away from this danger zone.

Remember, there are no guarantees in an active shooter/violent intruder situation, but just as in most other emergency situations the more you prepare, the better your chances of survival.

ALICE Frequently Asked Questions

Is ALICE to be followed chronologically?

No, ALICE is an acronym that is not linear. Occupants use the steps that are best for them. Evacuation is always the preferred action if it is safe to do so.

Are concealed weapons allowed on campus?

No. All weapons are prohibited on our campuses, this include all property - Buildings and Parking lots.

If we counter the attacker, won't it make him mad and make the situation worse?

The goal of the attack is to hurt as many people as possible in the time afforded. The objective cannot be made worse. In interviews, survivors of various active shooting events have reported the same thing time and time again: "the shooter's attitude was calm, cool, flat affect, systematic and 'on a mission' ". The emotion we do not hear is mad, upset or angry. Our goal is to affect them physically, emotionally and attempt to have a psychological impact to change the plan. Showing anger indicates the shooter is not being successful. This will likely lead to frustration and unplanned actions that will work to the benefit of those under attack.

If we do move out of a hiding place and try to gain distance or evacuate, won't that make it easier for the shooter to find us?

Staying in a danger area could expose you to the danger eventually, when taking the opportunity to exit the area removes the possibility. Should you be located, already engaging in the use of movement and gaining distance makes you a much harder target than just staying passive and static.

UTI will never run "surprise" active shooter drills – all drills will be preceded with notification that this is a DRILL.

Appendix I

Evacuation Route and Reunification Plan

Following the ALICE protocols for response to an active shooter event the Exton campus has partnered with the Upper Merion Police department for rally and reunification points for staff and students evacuating the facility to safely distance themselves from the emergency. Police will provide direction and if needed, transportation to an external reunification facility in the event of this type of emergency.

Appendix J

Screening and prevention requirements

In the event of a pandemic or localized infectious disease outbreak, UTI will follow guidance from the Centers for Disease Control and Prevention (CDC) and federal/state/local mandates.

In case of worldwide health emergencies or alerts from agencies such as the World Health Organization and/or the CDC, regarding infectious diseases that may be transmitted by person-to-person contact, we will take preventive measures to avoid or minimize the likelihood of spreading the infectious disease. All staff and students are urged to stay informed and to follow guidance issued by the Campus President and/or external agencies.