

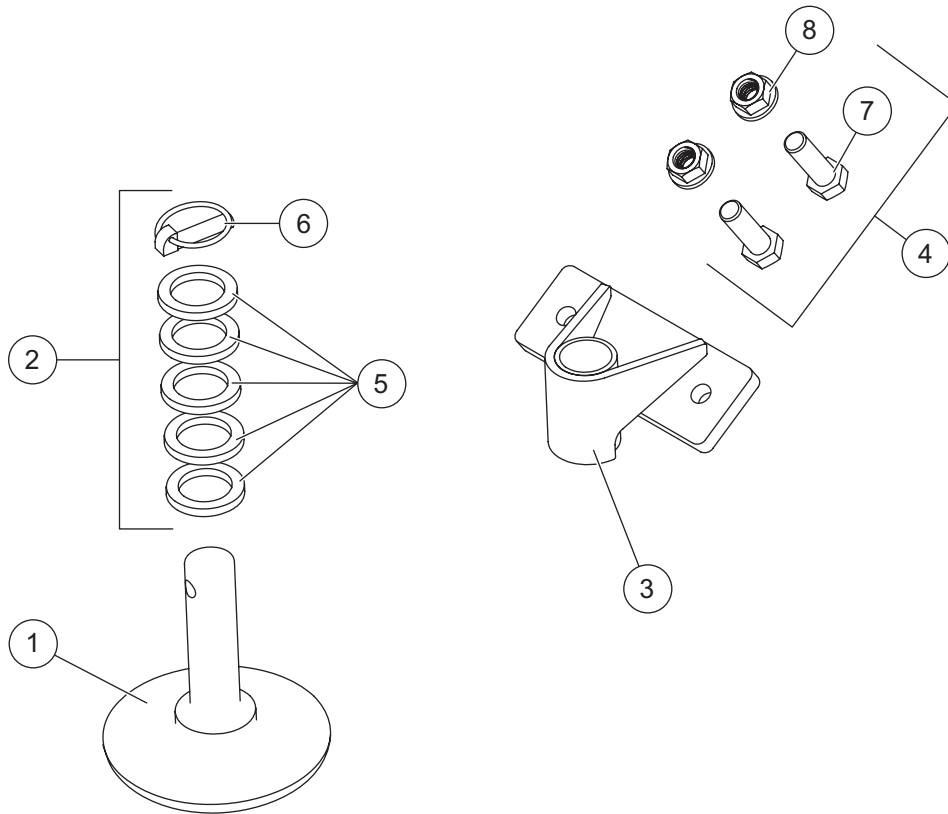

# Shoe Kit

## HD2™ Snowplow

### PARTS LIST



52506 Shoe Kit – HD2							
Item	Part	Qty	Description	Item	Part	Qty	Description
1	26523	2	Shoe 6" Solid Cast	3	52516	2	Shoe Bracket – HD2
2	52517	1	Parts Bag – Shoe	4	50697	1	Bolt Bag – Bracket
<b>Item 2</b>				<b>52517 Parts Bag – Shoe</b>			
	5	10	Shoe Spacer		6	2	Shoe Pin Packet
<b>Item 4</b>				<b>50697 Bolt Bag – Bracket</b>			
	7	4	5/8-11 x 2 Hex Cap Screw G5		8	4	5/8-11 Flanged Locknut GG
G = Grade							

## INSTALLATION INSTRUCTIONS

### ⚠ WARNING

Do not exceed GVWR or GAWR, including blade and ballast. The rating label is found on the driver-side vehicle door cornerpost.

### ⚠ WARNING

Blade can drop unexpectedly. Place blade on jack stands. Failure to do so could result in serious personal injury.

### ⚠ CAUTION

Read this document before installing the Shoe Kit.

### ⚠ CAUTION

Use standard methods and practices when attaching snowplow and installing accessories, including proper personal protective safety equipment.

### ⚠ CAUTION

See your FISHER® outlet/Web site for specific vehicle application recommendations before installation. Shoe Kit weight information may be found in the eMatch tool.

1. Park the vehicle on a smooth, level, hard surface, such as concrete. Raise the blade, then turn the control OFF.
2. From the front of the blade assembly, place jack stands under the blade.
3. Turn the control ON and lower the blade so the blade rests securely on the jack stands. Turn the control OFF. Turn the vehicle ignition to the "OFF" position and remove the key.
4. Insert a 5/8" x 2" cap screw up through each of the two outer holes in the base angle. Install the shoe bracket, 5/8" flange locknuts as shown. Tighten the fasteners to 150 ft-lb.

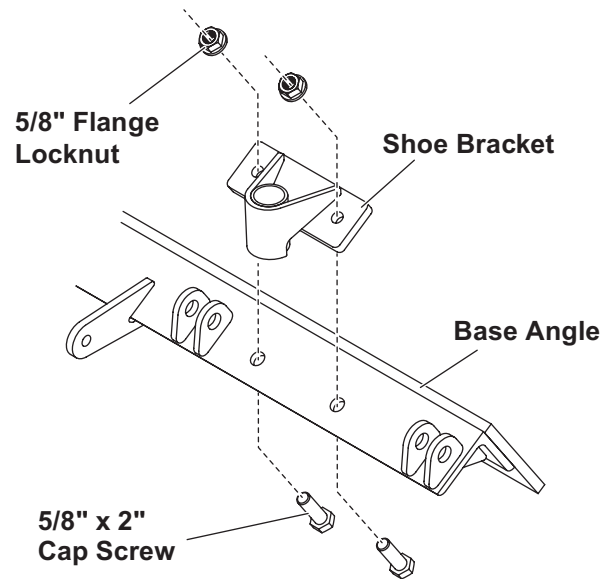

5. Repeat for the opposite side.

**⚠ CAUTION**

**Do not store unused spacers on top of the shoe holder. This could damage the blade.**

6. Insert the shoe stem into the bracket and adjust the shoe to desired height by adding/removing spacers. Secure the shoe with a linchpin.

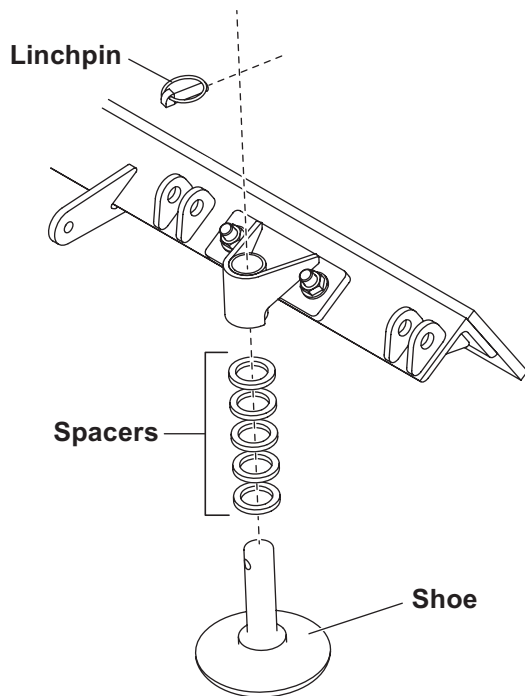

7. Repeat for opposite the side.
8. Turn the vehicle ignition and snowplow control ON. Raise the blade slightly. Turn the control OFF and remove the jack stands.
9. Stand 8 feet clear of the blade, and lower the blade to the ground.

Copyright © 2015 Douglas Dynamics, LLC. All rights reserved. This material may not be reproduced or copied, in whole or in part, in any printed, mechanical, electronic, film or other distribution and storage media, without the written consent of Fisher Engineering. Authorization to photocopy items for internal or personal use by Fisher Engineering outlets or snowplow owner is granted.

Fisher Engineering reserves the right under its product improvement policy to change construction or design details and furnish equipment when so altered without reference to illustrations or specifications used. Fisher Engineering or the vehicle manufacturer may require or recommend optional equipment for snow removal. Do not exceed vehicle ratings with a snowplow. Fisher Engineering offers a limited warranty for all snowplows and accessories. See separately printed page for this important information. The following are registered (®) or unregistered (™) trademarks of Douglas Dynamics, LLC: FISHER®, HD2™.

**Printed in U.S.A.**

---