



Rubber Deflector Kit

EZ-V® 7'6" and XV2™ Snowplows

PARTS LIST

18" Deflector Shown

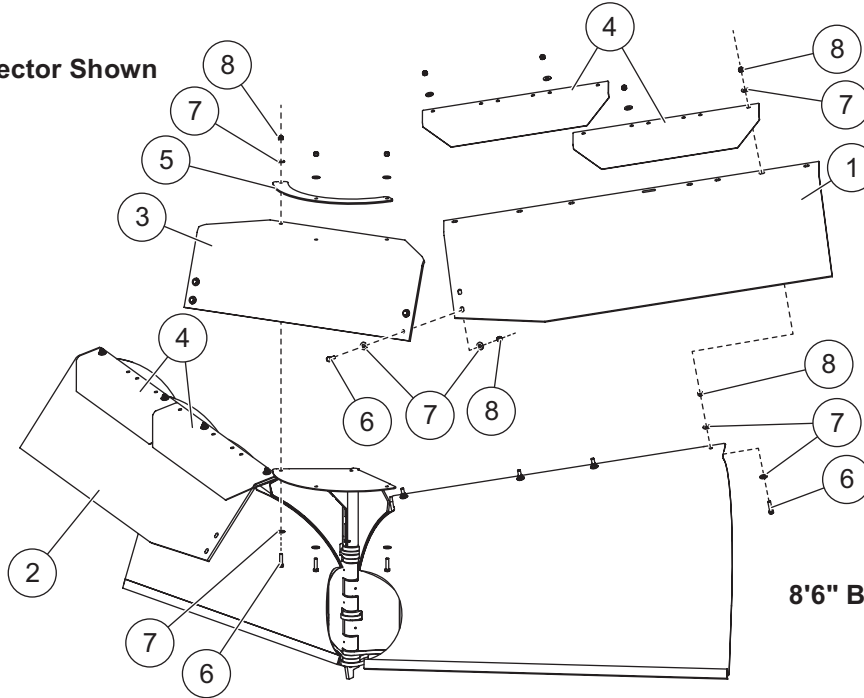

8" Blade Shown

41812-1 (10") / 41813-1 (18") Rubber Deflector Kit							
Item	Part	Qty	Description	Item	Part	Qty	Description
1	30157	1	10" Rubber Deflector FE – DS	4	43545	4	10" Deflector Hold-Down
	30155	1	18" Rubber Deflector FE – DS		43264	4	18" Deflector Hold-Down
2	41718	1	10" Rubber Deflector – PS	5*	43405	1	Center Deflector Hold-Down
	41721	1	18" Rubber Deflector – PS	ns	43620	1	Bolt Bag, Rubber Deflector Kit – 10"
3*	41744	1	Rubber Deflector – Center	ns	41745	1	Bolt Bag, Rubber Deflector Kit – 18"
86872 (10") / 86874 (18") 10'6" Rubber Deflector Kit							
1	77673	1	10" Rubber Deflector FE – DS	4	86855	4	10" Deflector Hold-Down
	77676	1	18" Rubber Deflector FE – DS		86856	4	18" Deflector Hold-Down
2	77675	1	10" Rubber Deflector – PS	5*	43405	1	Center Deflector Hold-Down
	77678	1	18" Rubber Deflector – PS	ns	43620	1	Bolt Bag, Rubber Deflector Kit – 10"
3*	41744	1	Rubber Deflector – Center	ns	41745	1	Bolt Bag, Rubber Deflector Kit – 18"
43620 Bolt Bag, Rubber Deflector Kit – 10"							
6		10	3/8-16 x 1-1/2 Hex Cap Screw G5	8		20	3/8-16 Hex Locknut GB
7		30	3/8 Flat Washer				
41745 Bolt Bag, Rubber Deflector Kit – 18"							
6		15	3/8-16 x 1-1/2 Hex Cap Screw G5	8		23	3/8-16 Hex Locknut GB
7		38	3/8 Flat Washer				
ns = not shown				G = Grade			

* In 41813-1 Rubber Deflector Kit (18") only.

INSTALLATION INSTRUCTIONS

⚠ WARNING

Do not exceed GVWR or GAWR, including blade and ballast. The rating label is found on the driver-side vehicle door cornerpost.

⚠ CAUTION

Read this document before installing the rubber deflector kit.

⚠ CAUTION

Use standard methods and practices when attaching snowplow and installing accessories, including proper personal protective safety equipment.

⚠ CAUTION

See your FISHER® outlet/website for specific vehicle application recommendations before installation. Rubber deflector weight information may be found in the eMatch selection system.

Park the vehicle on a smooth, level, hard surface, such as concrete. Lower the blade to the ground and turn the control OFF. Turn the vehicle ignition to the "OFF" position and remove the key.

Install Wing Deflectors

NOTE: Do not install 18" deflectors on EZ-V® 7'6" snowplows.

NOTE: For EZ-V 7'6" snowplows with a mild steel blade, skip Step 1 and begin at Step 2.

NOTE: EZ-V 7'6" snowplows use five fasteners per deflector. XV2™ snowplows use four fasteners per deflector.

1. Remove and discard the 3/8" x 1" button cap screws, 3/8" washers, and 3/8" locknuts that secure the moldboard to the blade frame. Do not allow the moldboard to shift out of position.

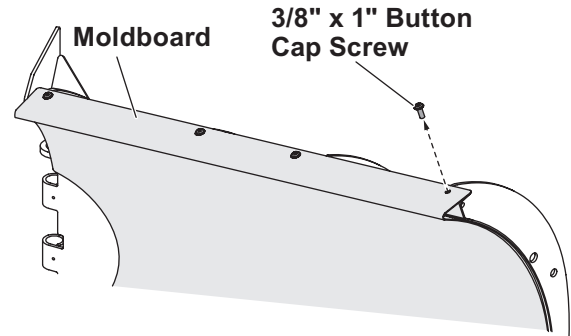

2. Install the supplied 3/8" x 1-1/2" cap screws and 3/8" flat washers through the blade frame and the moldboard from the bottom up. Install a second 3/8" flat washer and 3/8" locknut to each cap screw and tighten.

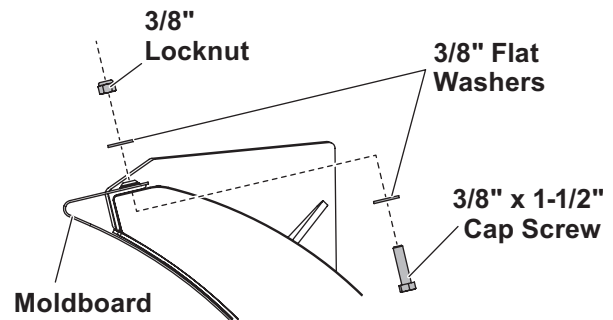

NOTE: On 7'6" and 8'6" blades, the deflector will overhang one end of the wing as shown.

3. **10" Deflector:** Set the driver-side deflector over the fasteners, with the outermost cap screw through the outer hole.

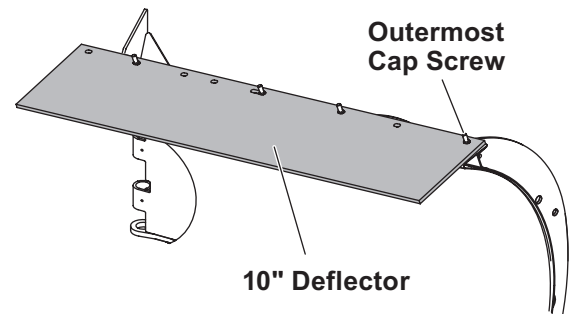

18" Deflector: Place the driver-side deflector over the fasteners, with the innermost cap screw through the inner hole.

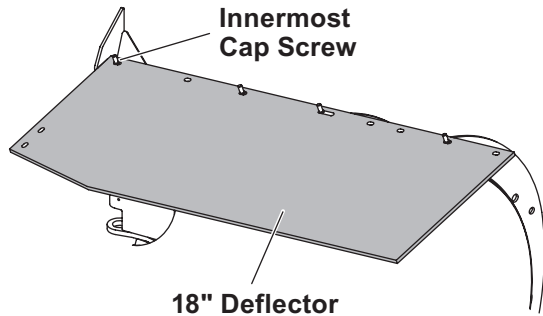

4. Place one hold-down over the deflector, with the outermost cap screw through the outermost hold-down hole.

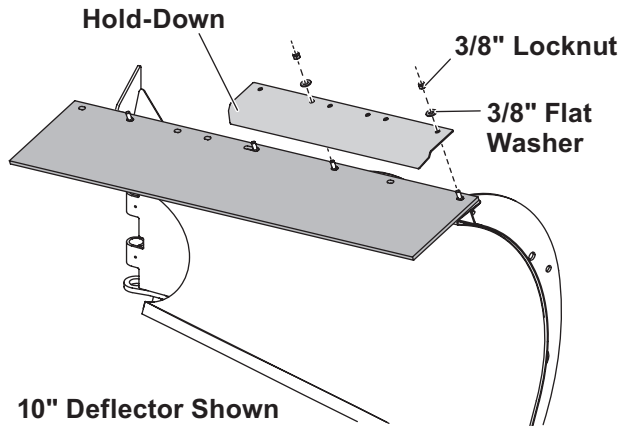

5. Install one 3/8" flat washer and 3/8" locknut on top of the outermost cap screw and hand tighten. Repeat for the second cap screw.

6. Place a second hold-down over the deflector, with the innermost cap screw through the innermost hold-down hole. The hold-downs may overlap. Install one 3/8" flat washer and 3/8" locknut on each cap screw attaching the second hold-down.

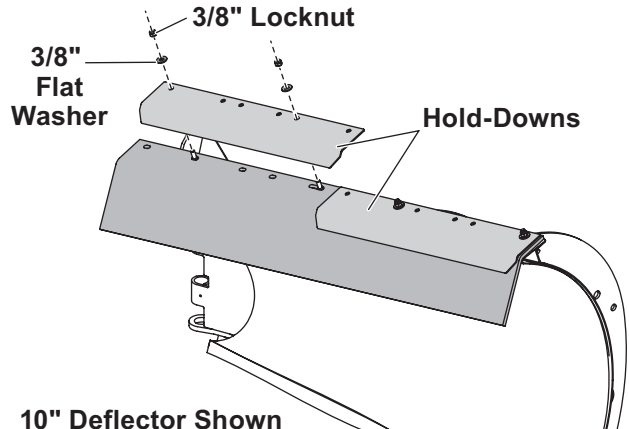

7. Make sure that the hold-downs are tight against the deflector, then fully tighten all of the locknuts.

8. **7'6" and 8'6" Blades Only:** Trim excess length from the rubber deflector as shown below.

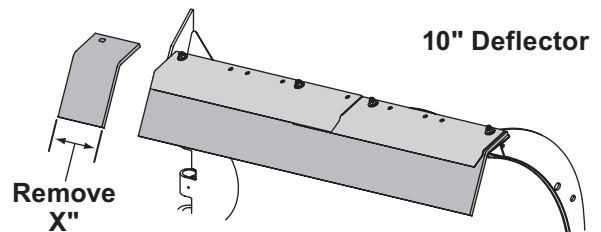

Blade Size	X
7'6"	12"
8'6"	6"
9'6"	None
10'6"	None

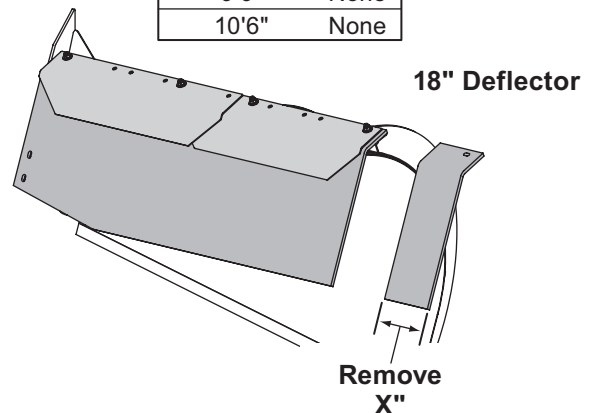

9. Repeat Steps 1 through 8 for the passenger-side blade wing.

**Install Center Deflector
(18" deflector only)**

⚠ WARNING
 Keep 8' clear of the blade when it is being raised, lowered, or angled. Do not stand between vehicle and blade or directly in front of the blade. If the blade hits or drops on you, you could be seriously injured.

1. With the blade in the retracted (vee) position, attach the center rubber deflector and center deflector hold-down to the steel center deflector using the provided 3/8" x 1-1/2" cap screws, 3/8" flat washers, and 3/8" locknuts. Make sure that the cap screws are installed from the bottom up.

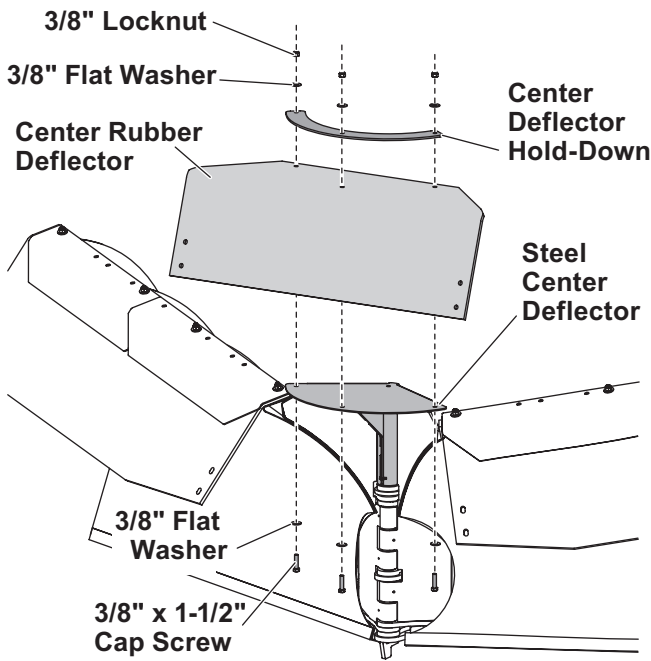

2. Attach the center rubber deflector to the wing rubber deflectors using the provided 3/8" x 1-1/2" cap screws, 3/8" flat washers, and 3/8" locknuts in the pre-made holes.

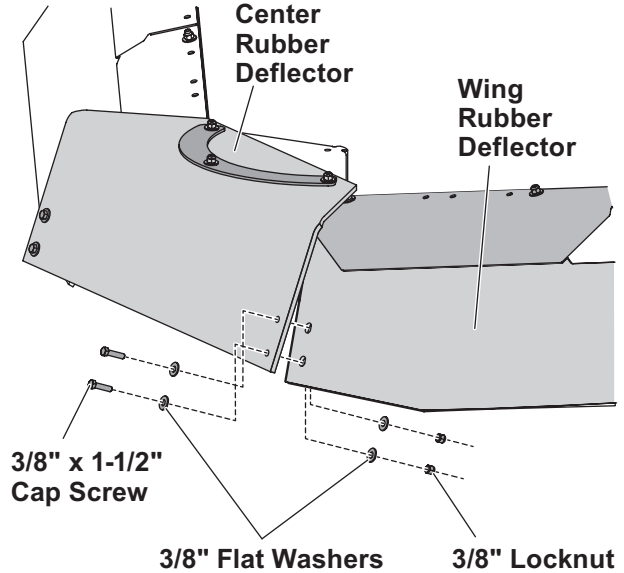

NOTE: It is normal for the rubber center deflector to bunch up when the blade is angled or moved into the scoop position.

Copyright © 2024 Douglas Dynamics, LLC. All rights reserved. This material may not be reproduced or copied, in whole or in part, in any printed, mechanical, electronic, film, or other distribution and storage media, without the written consent of Fisher Engineering. Authorization to photocopy items for internal or personal use by Fisher Engineering outlets or snowplow owner is granted.

Fisher Engineering reserves the right under its product improvement policy to change construction or design details and furnish equipment when so altered without reference to illustrations or specifications used. Fisher Engineering or the vehicle manufacturer may require or recommend optional equipment for snow removal. Do not exceed vehicle ratings with a snowplow. Fisher Engineering offers a limited warranty for all snowplows and accessories. See separately printed page for this important information. The following are registered (®) or unregistered (™) trademarks of Douglas Dynamics, LLC: EZ-V®, FISHER®, XV2™.

Printed in U.S.A.