

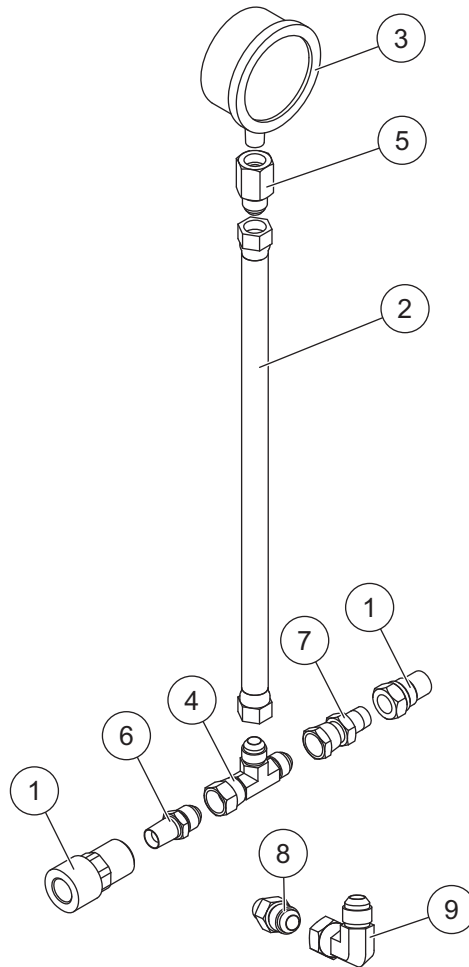

# Pressure Test Kit

## PARTS LIST



56679 Pressure Test Kit						
Item	Part	Qty	Description	Item	Part	Qty Description
1	25232K	1	Hyd Coupler 0.25 NPTF Poppet Check	6	56684	1 Connector, Male -6 M JIC/1/4 M NPTF
2	56616	1	Hose, 1/4 x 42 w/F JIC Ends	7	56685	1 Union, F Adapter 1/4 M NPTF/-6 F NPSM
3	56681	1	Gauge, 3,000 psi, Liquid Filled	8	48332	1 Connector, Short -6 M JIC/-4 M ORB
4	56682	1	Tee, Swivel Run -6 M JIC/-6 F JIC Swivel/-6 M JIC Swivel/-6 M JIC	9	56881	1 Elbow 90°, -6 F Swivel Flare/-6 M Flare
5	56683	2	Connector, Female -6 M JIC/1/4 F NPTF			
			M = Male	F = Female		

## SAFETY INFORMATION

Read these instructions and labels on the snowplow before beginning installation.

### **⚠ WARNING**

Indicates a potentially hazardous situation that, if not avoided, could result in death or serious personal injury.

### **⚠ CAUTION**

Indicates a potentially hazardous situation that, if not avoided, may result in minor or moderate injury. It may also be used to alert against unsafe practices.

**NOTE:** Indicates a situation or action that can lead to damage to your snowplow and vehicle or other property. Other useful information can also be described.

## INSTALLATION INSTRUCTIONS

### **⚠ WARNING**

The tester shall keep bystanders 8' clear of the blade drop zone during these tests. Do not stand between the vehicle and the blade or within 8 feet of a moving blade. A moving or falling blade could cause personal injury.

### **⚠ CAUTION**

Read this document before installing the Pressure Test Kit.

### **⚠ CAUTION**

Use standard methods and practices when attaching snowplow and installing accessories, including proper personal protective safety equipment.

## BEFORE PERFORMING ANY TESTS, VERIFY THE FOLLOWING:

- Snowplow is attached to vehicle and all harnesses are connected.
- Electrical connector pins and terminals are free of corrosion and tight.
- Vehicle battery connections are clean and tight and charging system is in good condition.
- Hydraulic reservoir is filled to recommended fluid level.
- Inspect all hydraulic fittings and hoses for leaks.

## IF TESTING A CENTRAL HYDRAULIC SYSTEM, VERIFY THE FOLLOWING:

- All hoses are connected properly to the snowplow.
- Drive belt is tight and in good condition.
- System pressure will not exceed supplied gauge pressure rating (3,000 psi).

## HYDRAULIC SAFETY

### WARNING

Hydraulic fluid under pressure can cause skin injection injury. If you are injured by hydraulic fluid, get medical attention immediately.

### CAUTION

Do not mix different types of hydraulic fluid. Some fluids are not compatible and may cause performance problems and product damage.

- Always inspect hydraulic components and hoses before using. Replace any damaged or worn parts immediately.
- If you suspect a hose leak, DO NOT use your hand to locate it. Use a piece of cardboard or wood.

## Hydraulic Fitting Connections

Do not use thread sealant/tape on hoses or fittings. These materials could damage the product.

### For SAE O-Ring fittings:

Using two wrenches, hold fitting body in position and tighten jam nut until the washer again contacts port face. Then tighten an additional 1/8 to 1/4 turn to lock fitting in place.

### For hydraulic fittings with flare ends:

Using two wrenches, hold the hose in position and tighten the flare nut 1/8 to 1/4 turn beyond hand tight.

## TRAILBLAZER™ UTV V-PLOW

### ⚠ WARNING

The tester shall keep bystanders 8' clear of the blade drop zone during these tests. Do not stand between the vehicle and the blade or within 8 feet of a moving blade. A moving or falling blade could cause personal injury.

**NOTE: Reservoir will contain residual pressure. Slowly remove, then reinstall, breather to release pressure before proceeding.**

1. Lower blade to the ground. Verify proper fluid level according to the Owner's Manual before beginning test.
2. Loosen hoses or fittings slowly to relieve any residual pressure. Wrap the fitting or hose connection with a disposable cloth to absorb residual fluid. When service is complete, dispose of cloth properly.
3. Carefully unscrew the plug in the test port.
4. Attach the 3,000 psi hydraulic pressure gauge to the test port using the components shown below.
5. Route the gauge near the driver-side headlamp and secure it so the gauge is visible from the cab.

6. Activate the LEFT ANGLE function until blade is fully angled.

**NOTE: Control will time out after 3.0 seconds. Repeat command if blade is not fully angled.**

7. Repeat the LEFT ANGLE function, and read the pressure shown on the gauge.
8. Refer to page 12 for troubleshooting, or to the TRAILBLAZER UTV V-Plow Mechanic's Guide (Lit. No. 72012) for additional information.

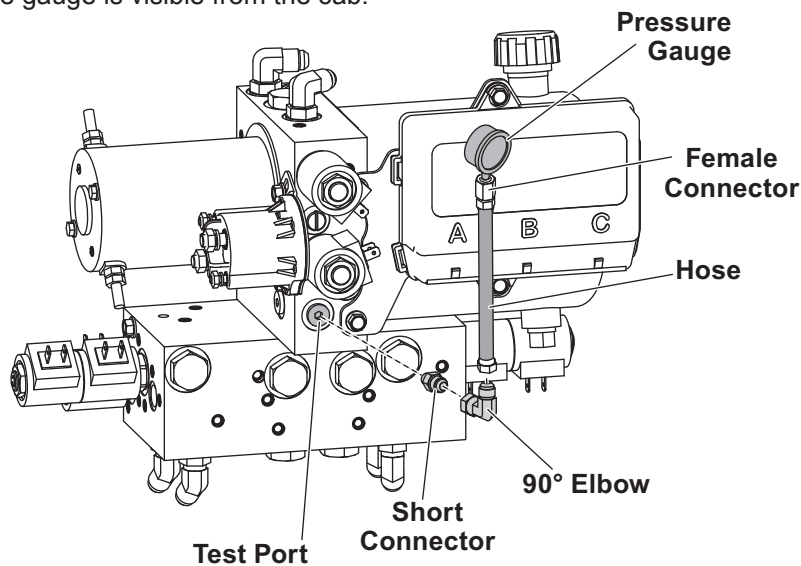
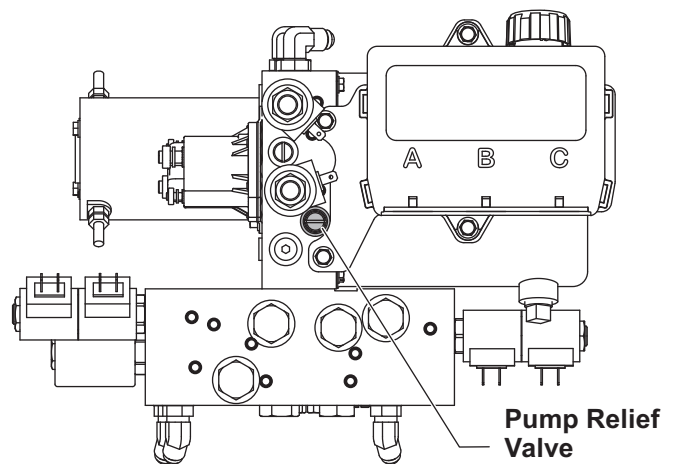

**Pump Relief Valve  
Pressure (± 100 psi)**

2,000

## Homesteader™ PERSONAL PLOW

### ⚠ WARNING

The tester shall keep bystanders 8' clear of the blade drop zone during these tests. Do not stand between the vehicle and the blade or within 8 feet of a moving blade. A moving or falling blade could cause personal injury.

**NOTE: Reservoir will contain residual pressure. Slowly remove, then reinstall, breather to release pressure before proceeding.**

1. Lower blade to the ground. Verify proper fluid level according to the Owner's Manual before beginning test.
2. Loosen hoses or fittings slowly to relieve any residual pressure. Wrap the fitting or hose connection with a disposable cloth to absorb residual fluid. When service is complete, dispose of cloth properly.
3. Carefully unscrew the passenger-side angle ram hose.
4. Attach the 3,000 psi hydraulic pressure gauge to the passenger-side ram using the components shown below.

5. Route the gauge near the driver-side headlamp and secure it so the gauge is visible from the cab.
6. Activate the LEFT ANGLE function until blade is fully angled.

**NOTE: Control will time out after 5.5 seconds. Repeat command if blade is not fully angled.**

7. Repeat the LEFT ANGLE function, and read the pressure shown on the gauge.
8. Refer to the table on page 12 for main pump relief troubleshooting; Lit. No. 28033 for scrape lock adjustment; and the HT Series™ Mechanic's Guide (Lit. No. 41298) for all other adjustments.

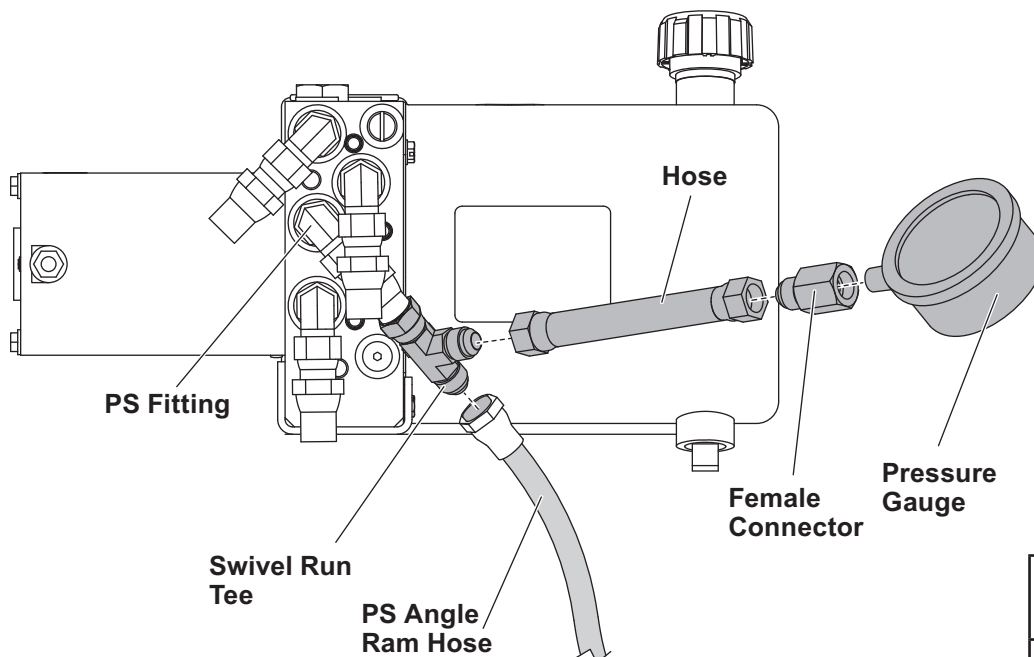
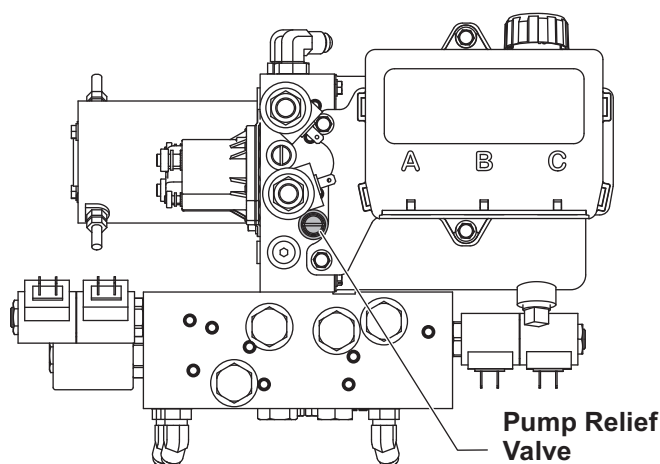

**Pump Relief Valve  
Pressure ( $\pm 100$  psi)**

1,750

**HT Series™ SNOWPLOW**

**⚠ WARNING**

The tester shall keep bystanders 8' clear of the blade drop zone during these tests. Do not stand between the vehicle and the blade or within 8 feet of a moving blade. A moving or falling blade could cause personal injury.

**NOTE: Reservoir will contain residual pressure. Slowly remove, then reinstall, breather to release pressure before proceeding.**

1. Lower blade to the ground. Verify proper fluid level according to the Owner's Manual before beginning test.
2. Loosen hoses or fittings slowly to relieve any residual pressure. Wrap the fitting or hose connection with a disposable cloth to absorb residual fluid. When service is complete, dispose of cloth properly.
3. Carefully unscrew the passenger-side angle ram hose.
4. Attach the 3,000 psi hydraulic pressure gauge to the passenger-side ram using the components shown below.
5. Route the gauge near the driver-side headlamp and secure it so the gauge is visible from the cab.

6. Activate the LEFT ANGLE function until blade is fully angled.

**NOTE: Control will time out after 5.5 seconds. Repeat command if blade is not fully angled.**

7. Repeat the LEFT ANGLE function, and read the pressure shown on the gauge.
8. Refer to page 12 or the HT Series Mechanic's Guide (Lit. No. 41298) for additional information.

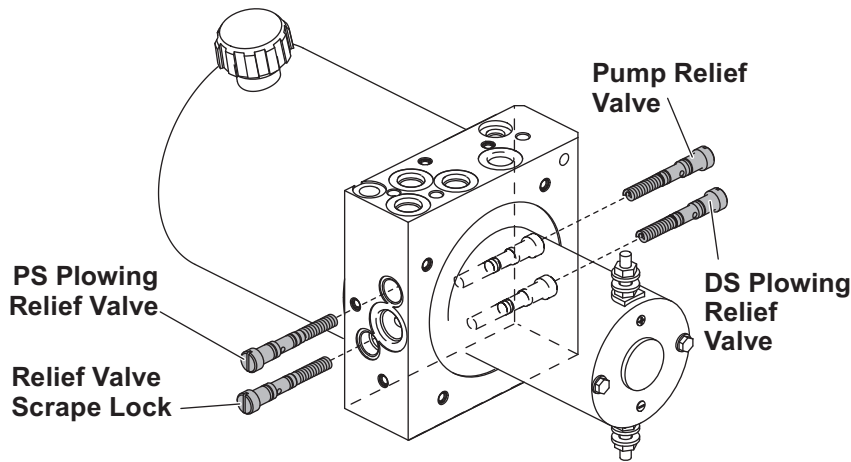
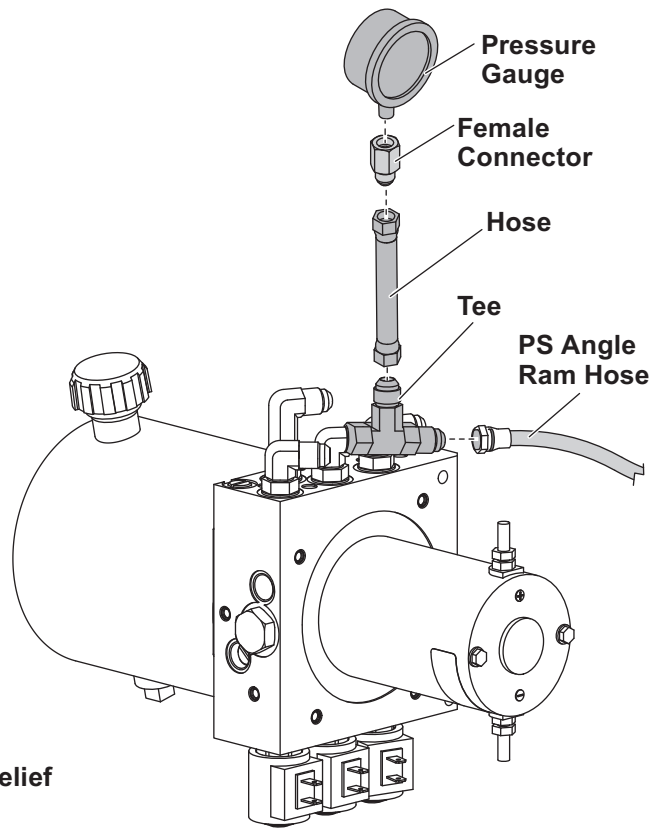

<b>Pump Relief Valve Pressure (± 100 psi)</b>
1,650

## STRAIGHT BLADES with Insta-Act® HYDRAULIC SYSTEM

### ⚠ WARNING

The tester shall keep bystanders 8' clear of the blade drop zone during these tests. Do not stand between the vehicle and the blade or within 8 feet of a moving blade. A moving or falling blade could cause personal injury.

1. Lower the blade to the ground. Place control in FLOAT mode, and fully collapse the lift cylinder. Check fluid level according to Owner's Manual.
2. Loosen hoses or fittings slowly to relieve any residual pressure. Wrap the fitting or hose connection with a disposable cloth to absorb residual fluid. When service is complete, dispose of cloth properly.
3. Route the gauge near the driver-side headlamp and secure it so the gauge is visible from the cab.
4. Activate the ANGLE LEFT function until blade is fully angled. Repeat the ANGLE LEFT function, and read the pressure shown on the gauge.
5. The pressure should be 1,750 or 2,250 psi (refer to table below). Adjust the pump pressure if necessary. To adjust the pressure, turn the pump relief valve clockwise to increase the pressure, or counterclockwise to decrease pressure. Do not adjust the pressure setting more than 1/4 turn at a time. **Do not adjust the relief valve while the motor is running.**
6. Refer to page 12 for more information.

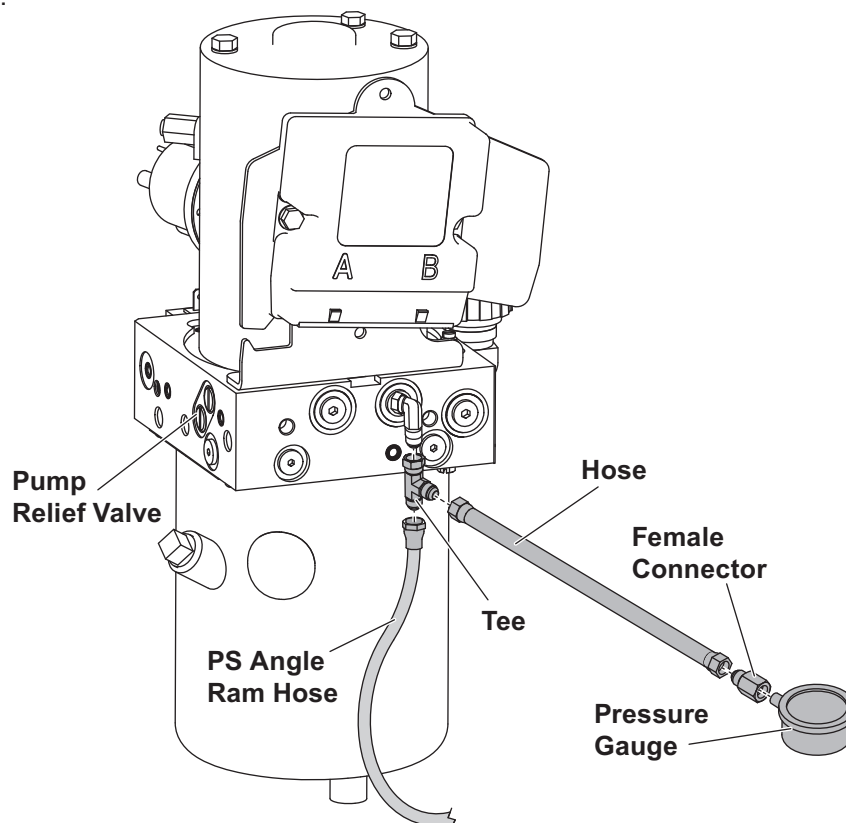

Snowplow Type	Pump Relief Valve Pressure ( $\pm 100$ psi)
Pre-FLEET FLEX Models	1,750
FLEET FLEX Models	2,250

**EZ-V® SNOWPLOWS: Insta-Act® HYDRAULIC SYSTEM with PIPE FITTINGS**

**⚠ WARNING**

The tester shall keep bystanders 8' clear of the blade drop zone during these tests. Do not stand between the vehicle and the blade or within 8 feet of a moving blade. A moving or falling blade could cause personal injury.

1. Lower the blade to the ground, and fully collapse the lift cylinder. Check fluid level according to Owner's Manual.
2. Carefully unscrew the passenger-side rod angle ram hose. Attach the 3,000 psi hydraulic pressure gauge using the components shown below.

3. Route the gauge near the driver-side headlamp and secure it so the gauge is visible from the cab.
4. Activate the PASSENGER-SIDE WING RETRACT function until ram is fully retracted. Repeat the PASSENGER-SIDE WING RETRACT function and read the pressure shown on the gauge.
5. The pressure should be  $1,750 \pm 100$  psi. Adjust the pump pressure if necessary. To adjust the pressure, turn the pump relief valve clockwise to increase the pressure, or counterclockwise to decrease pressure. Do not adjust the pressure setting more than 1/4 turn at a time. **Do not adjust the relief valve while the motor is running.**
6. Refer to page 12 or the EZ-V Mechanic's Guide (Lit. No. 27180) for additional information.

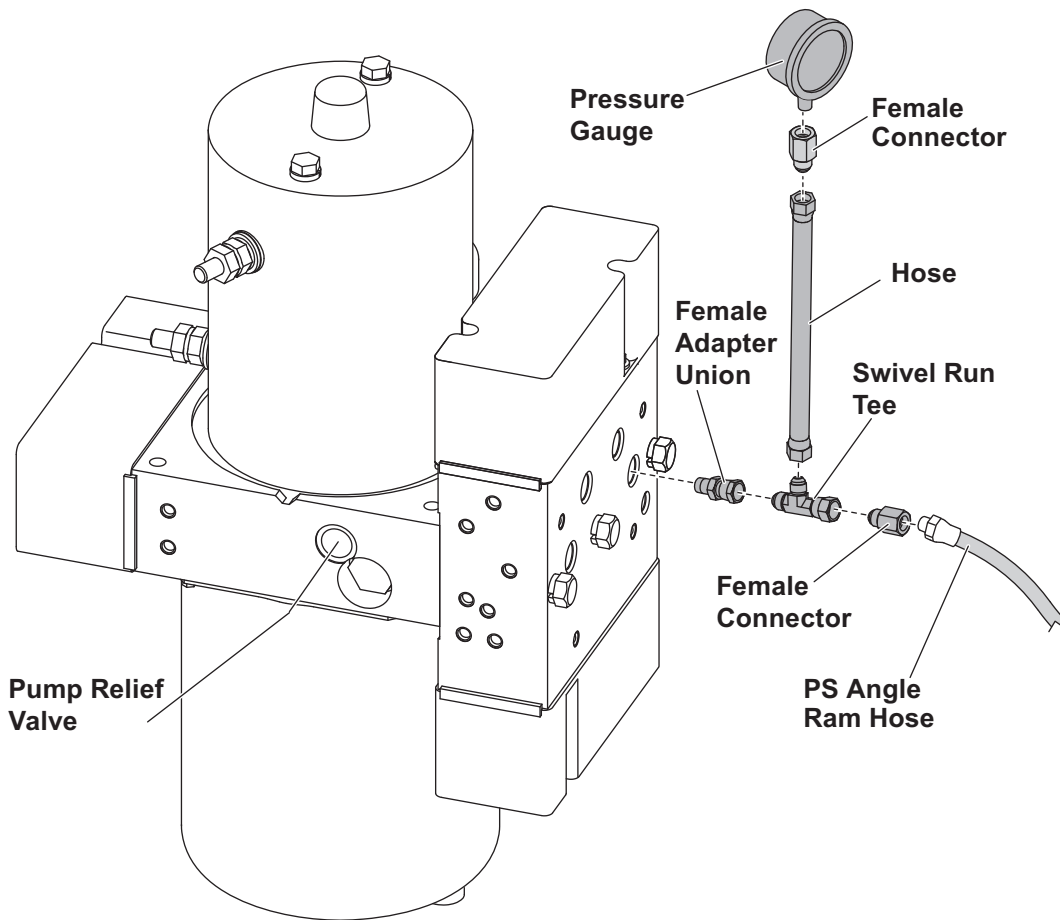

<b>Pump Relief Valve Pressure (<math>\pm 100</math> psi)</b>
1,750



## EZ-V® SNOWPLOWS: Insta-Act® HYDRAULIC SYSTEM with FLARE FITTINGS

### ⚠ WARNING

The tester shall keep bystanders 8' clear of the blade drop zone during these tests. Do not stand between the vehicle and the blade or within 8 feet of a moving blade. A moving or falling blade could cause personal injury.

1. Lower the blade to the ground, and fully collapse the lift cylinder. Check fluid level at fill plug.
2. Carefully unscrew the passenger-side rod angle ram hose. Attach the 3,000 psi hydraulic pressure gauge using the components shown below.
3. Route the gauge near the driver-side headlamp and secure it so the gauge is visible from the cab.
4. Activate the PASSENGER-SIDE WING RETRACT function until ram is fully retracted. Repeat the PASSENGER-SIDE WING RETRACT function and read the pressure shown on the gauge.
5. The pressure should be  $1,750 \pm 100$  psi. Adjust the pump pressure if necessary. To adjust the pressure, turn the pump relief valve clockwise to increase the pressure, or counterclockwise to decrease pressure. Do not adjust the pressure setting more than 1/4 turn at a time. **Do not adjust the relief valve while the motor is running.**
6. Refer to page 12 or the EZ-V Mechanic's Guide (Lit. No. 26512) for additional information.

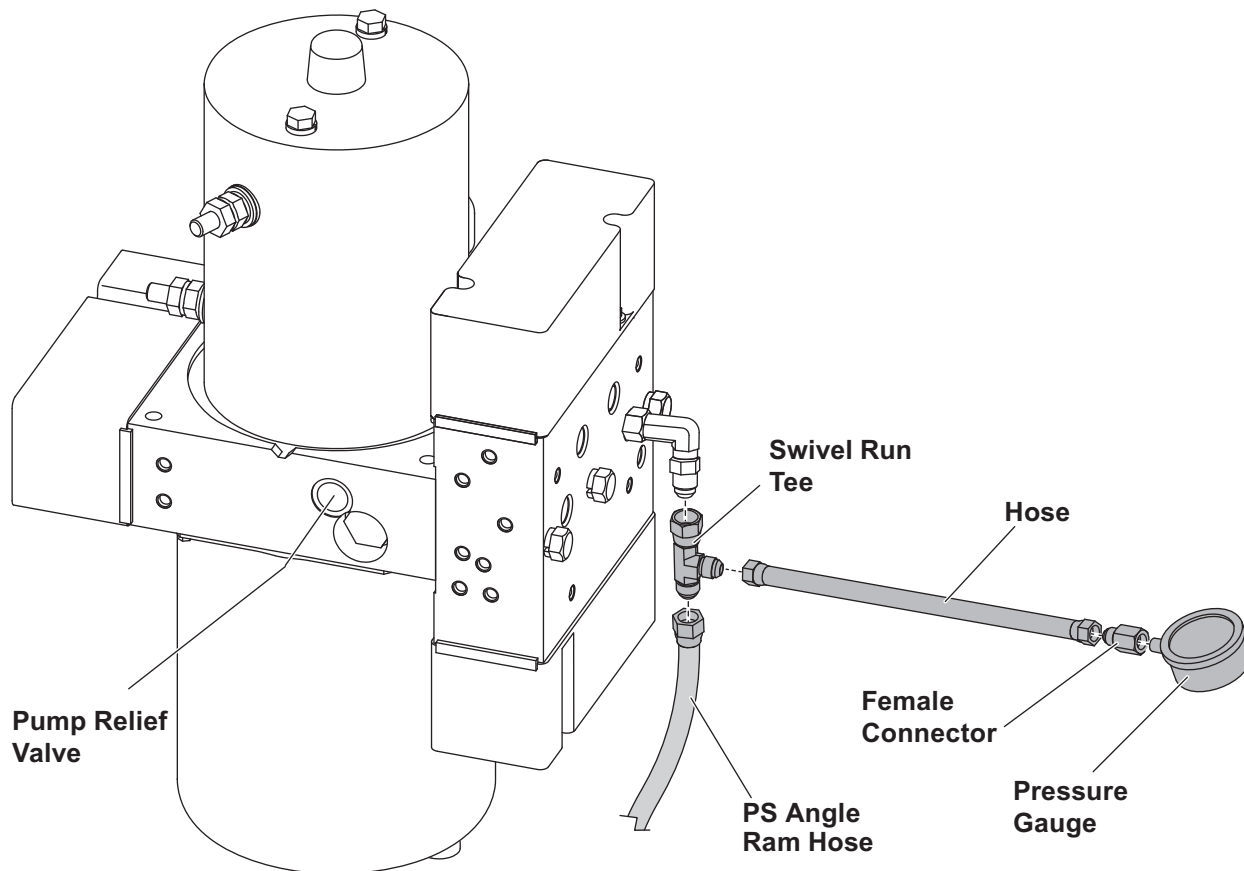

**Pump Relief Valve  
Pressure ( $\pm 100$  psi)**

1,750

**Xtreme V™ & XV2™ SERIES  
SNOWPLOWS**

**⚠ WARNING**

The tester shall keep bystanders 8' clear of the blade drop zone during these tests. Do not stand between the vehicle and the blade or within 8 feet of a moving blade. A moving or falling blade could cause personal injury.

**NOTE: The reservoir will contain residual pressure. Remove, then reinstall, the breather to release pressure before proceeding.**

1. Lower the blade to the ground and collapse the lift cylinder. Verify proper fluid level according to the Owner's Manual before running the test.
2. Loosen hoses or fittings slowly to relieve any residual pressure. Wrap the fitting or hose connection with a disposable cloth to absorb residual fluid. When service is complete, dispose of cloth properly.
3. Remove the plug in the pressure test port and attach a 3,000 psi hydraulic pressure gauge to pressure test port, as shown in the illustration.
4. Activate the RIGHT RETRACT function until the blade is fully retracted.

**NOTE: The control will time out after 3 seconds. Repeat the command if the blade is not yet fully retracted.**

5. Repeat the RIGHT RETRACT function, and read the pressure shown on the gauge.
6. Refer to page 12 or the Xtreme V Mechanic's Guide (Lit. No. 27365) for additional information.

BLADE MOVEMENT		RIGHT RETRACT
MOTOR	M	ON

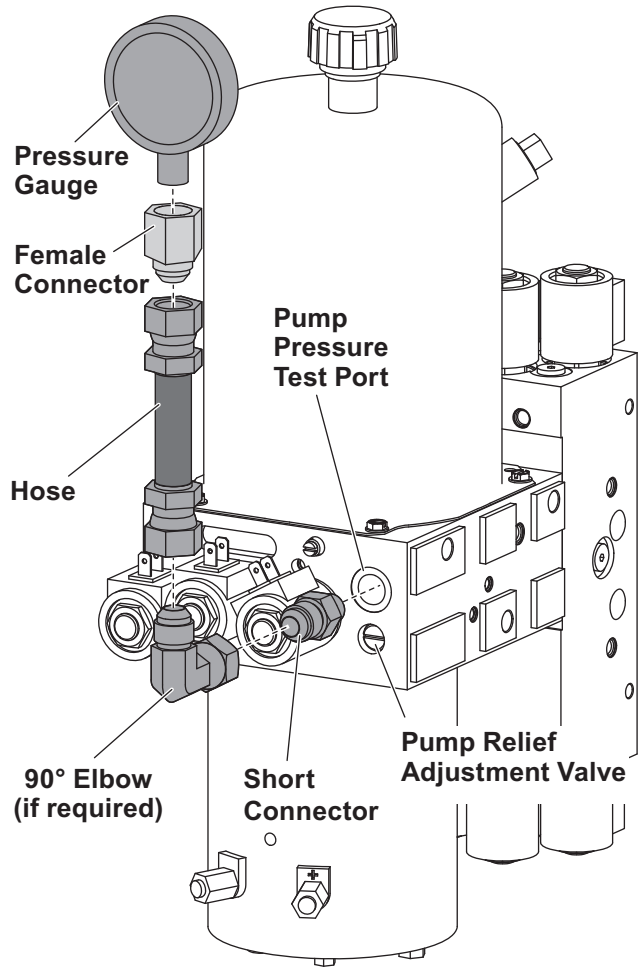

<b>Pump Relief Valve Pressure (± 100 psi)</b>
2,250

## XLS™ SNOWPLOWS

**⚠ WARNING**

The tester shall keep bystanders 8' clear of the blade drop zone during these tests. Do not stand between the vehicle and the blade or within 8 feet of a moving blade. A moving or falling blade could cause personal injury.

**NOTE:** The reservoir will contain residual pressure. Remove, then reinstall, the breather to release pressure before proceeding.

1. Lower the blade to the ground and collapse the lift cylinder. Verify proper fluid level according to the Owner's Manual before running the test.
2. Remove the plug in the pressure test port and attach a 3,000 psi hydraulic pressure gauge to pressure test port, as shown in the illustration.
3. Activate the ANGLE function either left or right until blade is fully angled.

**NOTE:** The control will time out after 3.25 seconds. Repeat the command if the blade is not yet fully angled.

4. Repeat the ANGLE function, and read the pressure shown on the gauge.
5. Refer to page 12 or the XLS Mechanic's Guide (Lit. No. 27375) for additional information.

BLADE MOVEMENT		ANGLE RIGHT	ANGLE LEFT
MOTOR	M	ON	ON

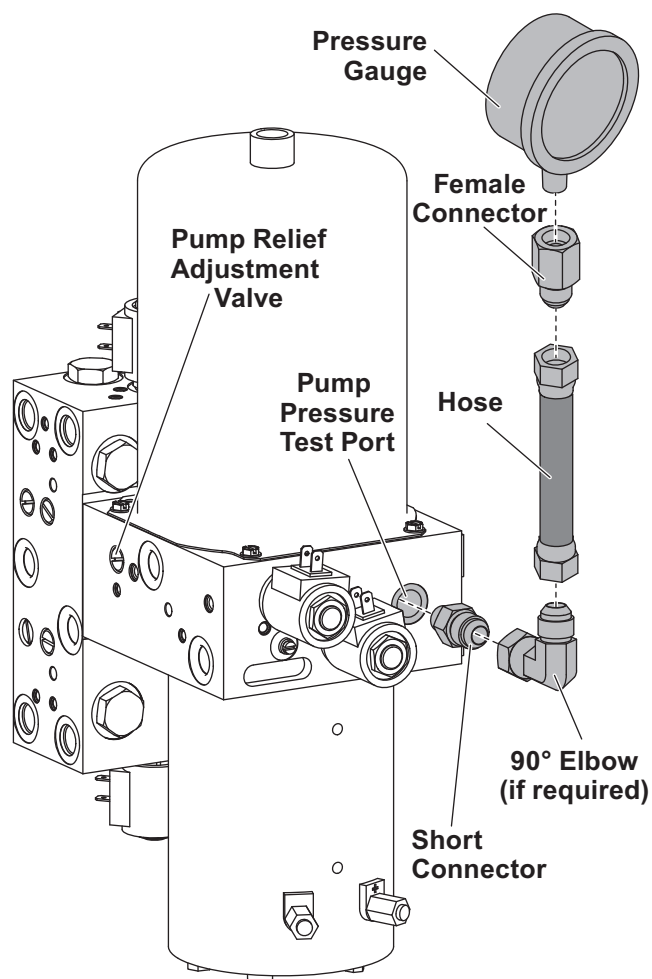

**Pump Relief Valve  
Pressure ( $\pm 100$  psi)**

2,250

## Insta-Act® HYDRAULIC SYSTEM TROUBLESHOOTING

**NOTE:** This section does not apply to systems described on pages 13, 14 or 15.

Condition	Possible Cause	Corrective Action
<b>Pump pressure is not at set point <math>\pm</math> 100 psi</b>	Pump Relief Valve	<ul style="list-style-type: none"> <li>Pump relief valve may be out of adjustment. Turn relief valve clockwise 1/4 turn and retest pressure. Repeat until correct pressure (set point pressure) is obtained.</li> </ul>
		<ul style="list-style-type: none"> <li>If correct pressure is not obtained after readjustment, remove and inspect the relief valve and its components. Check O-ring, stem and ball for wear or damage. Reseat ball or replace relief valve as needed. Reinstall/replace and readjust valve, then retest pump pressure.</li> </ul>
	O-Ring (between pump and valve block)	<ul style="list-style-type: none"> <li>Remove the pump and inspect the O-ring between the pump and the valve block for damage. Reinstall/replace O-ring and pump, then retest pump pressure.</li> </ul>
	Pump	<ul style="list-style-type: none"> <li>Remove the pump and inspect it for wear or broken gears. Replace pump if needed. Adjust pump relief valve, then retest pressure.</li> </ul>
<b>4.5" Motor draws more than 265 Amp at pump relief</b>	Motor	<ul style="list-style-type: none"> <li>Replace the motor.</li> </ul>
<b>3" Motor draws more than 160 Amp at pump relief</b>		

## SNOWPLOWS with BELT DRIVE and CENTRAL HYDRAULICS

### ⚠ WARNING

The tester shall keep bystanders 8' clear of the blade drop zone during these tests. Do not stand between the vehicle and the blade or within 8 feet of a moving blade. A moving or falling blade could cause personal injury.

1. Lower the blade to the ground and check fluid level.
2. Remove the hose quick disconnect to the driver-side angle cylinder at vehicle grille (Minute Mount® attachments) or headgear (conventional attachments). Connect the pressure gauge with hose and appropriate disconnect fitting to mating vehicle-side fitting.

3. Route the hose and gauge near the driver-side headlamp and secure it so the gauge is visible from the cab.
4. Start the engine and move the control to angle right. Read the gauge.
5. Verify that the pump pressure is within system requirements.

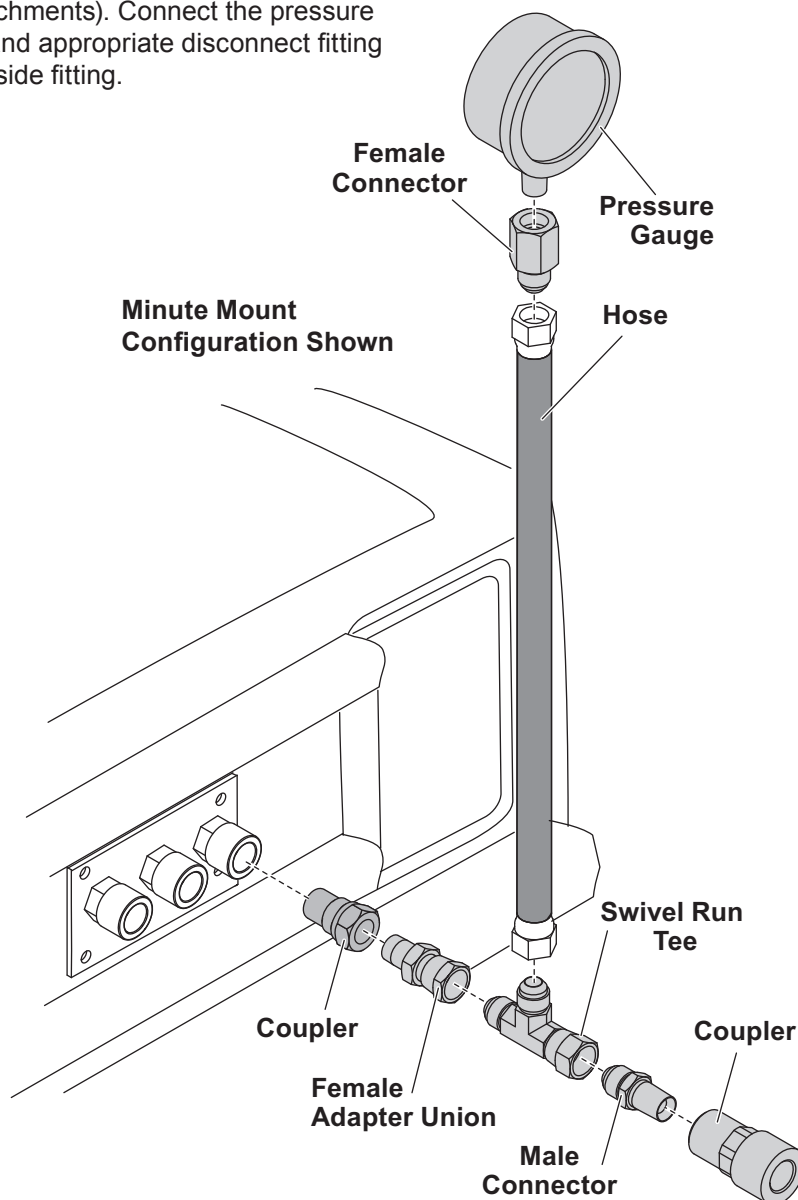

**SNOWPLOWS with SEHP HYDRAULIC SYSTEM**

**⚠ WARNING**

The tester shall keep bystanders 8' clear of the blade drop zone during these tests. Do not stand between the vehicle and the blade or within 8 feet of a moving blade. A moving or falling blade could cause personal injury.

1. Lower the blade to the ground, and fully collapse the lift cylinder. Check fluid level at fill plug.
2. Carefully disconnect the 1/4" pipe plug from the cylinder test port in the housing above the manifold block. Be aware of possible residual pressure in the lift cylinder. Attach the Test Gauge Kit to the lift cylinder test port.
3. Route the gauge near the driver-side headlamp and secure it so the gauge is visible from the cab.

4. Activate the RAISE function and read the pump relief pressure on the gauge when the blade is fully raised.
5. Refer to the illustration below for pump relief valve screw and lift cylinder test port locations. The chart lists relief pressure settings. Adjusting the pump relief valve **clockwise** 1/4 turn at a time will **increase** the pump pressure approximately 225 psi.

**NOTE: Early 2-piece die-cast pumps may require removal to adjust.**

6. Refer to the SEHP Hydraulics Mechanic's Guide (Lit. No. 21935) for additional information.

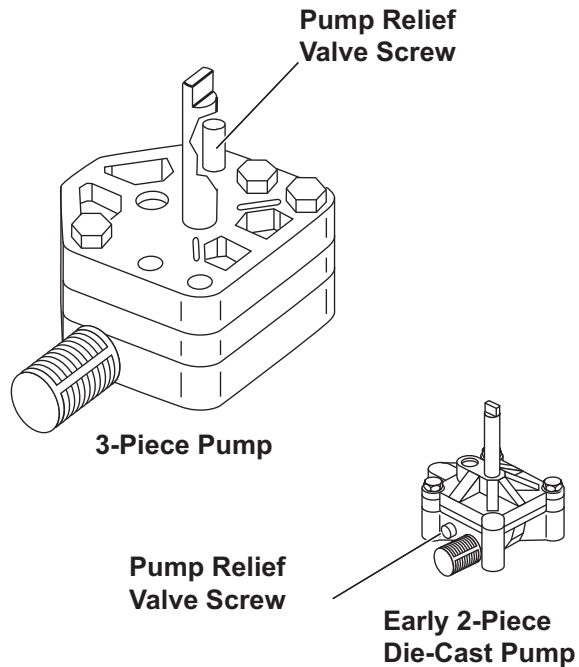
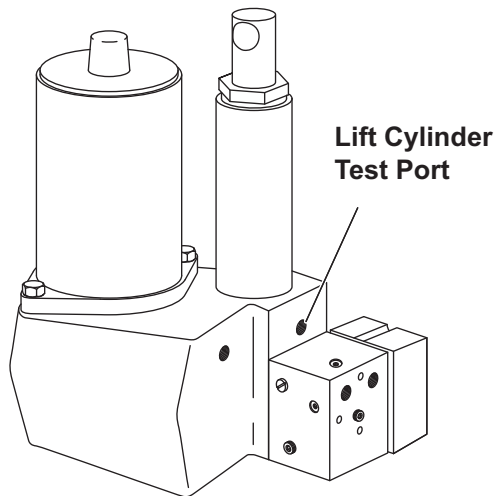

Snowplow Type	Pump Relief Valve Pressure (± 100 psi)
Regular, Heavy Duty	1,750
Commercial	2,100
Light Duty	1,750

## SNOWPLOWS with ELECTRIC HYDRAULIC UNIT (EHP)

### ⚠ WARNING

The tester shall keep bystanders 8' clear of the blade drop zone during these tests. Do not stand between the vehicle and the blade or within 8 feet of a moving blade. A moving or falling blade could cause personal injury.

1. Lower the blade to the ground, and fully collapse the lift cylinder. Check fluid level at fill plug.
2. Disconnect the hose to the passenger-side angle cylinder at the quick disconnect attached to the valve block.
3. Connect the pressure gauge equipped with hose and appropriate disconnect to the passenger-side disconnect in the valve block.

4. Route the gauge near the driver-side headlamp and secure it so the gauge is visible from the cab.
5. Move the control lever to angle left and read the pressure on the gauge. If the pressure is below 1,600 psi, adjusting the pump relief valve **clockwise** 1/4 turn at a time will **increase** the pump pressure approximately 225 psi.

**NOTE:** Early 2-piece die-cast pumps may require removal to adjust.

6. Refer to the Electric Hydraulic Pak Mechanic's Guide (Lit. No. 13492) for additional information.

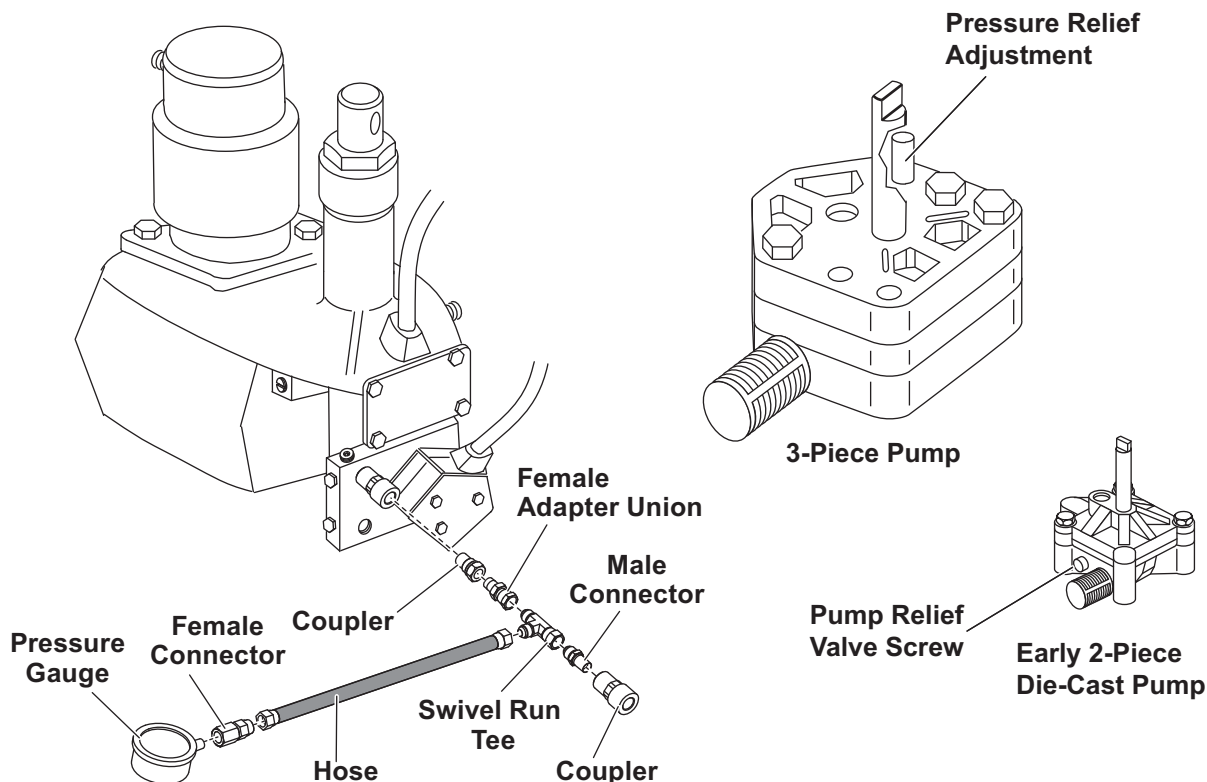

Snowplow Type	Pump Relief Valve Pressure ( $\pm 100$ psi)
All Models	1,750

Copyright © 2016 Douglas Dynamics, LLC. All rights reserved. This material may not be reproduced or copied, in whole or in part, in any printed, mechanical, electronic, film or other distribution and storage media, without the written consent of Fisher Engineering. Authorization to photocopy items for internal or personal use by Fisher Engineering outlets or snowplow owner is granted.

Fisher Engineering reserves the right under its product improvement policy to change construction or design details and furnish equipment when so altered without reference to illustrations or specifications used. Fisher Engineering or the vehicle manufacturer may require or recommend optional equipment for snow removal. Do not exceed vehicle ratings with a snowplow. Fisher Engineering offers a limited warranty for all snowplows and accessories. See separately printed page for this important information. The following are registered (®) or unregistered (™) trademarks of Douglas Dynamics, LLC: EZ-V®, FISHER®, Homesteader™, HT Series™, Insta-Act®, Minute Mount®, TRAILBLAZER™, XLS™, Xtreme V™, XV2™.

**Printed in U.S.A.**

---