

# Isolation Module/Control Tester

## 3-Port Isolation Modules 29070-1, 29760-1, 29760-2

## 4-Pin & 6-Pin Hand-Held Controls

## 4-Pin & 6-Pin Joystick Controls

### Operating Instructions



#### **⚠ CAUTION**

Read this document before using the isolation module/controls tester.



---

## CONTENTS

<b>SAFETY</b> .....	4
<b>OVERVIEW</b> .....	5
Harnesses and Power Connectors .....	5
<b>ISOLATION MODULE TEST – SETUP</b> .....	6
<b>ISOLATION MODULE TEST – OPERATION</b> .....	7
Test Modes .....	7
Stopping/Restarting a Test Cycle .....	7
Test Sequence .....	8
Test Results .....	8
Isolation Module Test Codes Reference .....	8
<b>CONTROL TESTS – SETUP</b> .....	9
<b>CONTROL TESTS – OPERATION</b> .....	10
4-Pin Control Test (Reserved Test–X) .....	10
6-Pin Control Test (Reserved Test–1) .....	12

## SAFETY DEFINITIONS

### **⚠ WARNING**

Indicates a potentially hazardous situation that, if not avoided, could result in death or serious personal injury.

### **⚠ CAUTION**

Indicates a potentially hazardous situation that, if not avoided, may result in minor or moderate injury. It may also be used to alert against unsafe practices.

**NOTE:** Indicates a situation or action that can lead to damage to your snowplow and vehicle or other property. Other useful information can also be described.

## SAFETY PRECAUTIONS

Improper installation and operation could cause personal injury and/or equipment and property damage. Read and understand labels these Operating Instructions before performing isolation module tests.

### **⚠ WARNING**

Lower the blade when the vehicle is parked. Temperature changes could change hydraulic pressure, causing the blade to drop unexpectedly or damaging hydraulic components. Failure to do this could result in serious personal injury.

### **⚠ WARNING**

The operator shall keep bystanders clear of the blade during this test. Do not stand between vehicle and blade or within 8 feet of a moving blade. A moving or falling blade could cause personal injury.

### **⚠ WARNING**

To prevent accidental movement of the blade, always turn the control OFF whenever the snowplow is not in use. The power indicator light will turn OFF.

## FUSES

The snowplow electrical and hydraulic systems contain several automotive-style fuses. If a problem should occur and fuse replacement is necessary, the replacement fuse must be of the same type and amperage rating as the original. Installing a fuse with a higher rating can damage the system and could start a fire. Fuse Replacement, including fuse ratings and locations, is located in the Maintenance section of the Owner's Manual.

## PERSONAL SAFETY

- Remove the ignition key and put the vehicle in PARK or in gear to prevent others from starting the vehicle during installation or service.
- Wear only snug-fitting clothing while working on your vehicle or snowplow.
- Do not wear jewelry or a necktie, and secure long hair.
- Wear safety goggles to protect your eyes from battery acid, gasoline, dirt, and dust.
- Avoid touching hot surfaces such as the engine, radiator, hoses, and exhaust pipes.
- Always have a fire extinguisher rated BC handy, for flammable liquids and electrical fires.

## BATTERY SAFETY

### **⚠ CAUTION**

Batteries normally produce explosive gases, which can cause personal injury. Therefore, do not allow flames, sparks, or lit tobacco to come near the battery. When charging or working near a battery, always cover your face and protect your eyes, and also provide ventilation.

- Batteries contain sulfuric acid, which burns skin, eyes, and clothing.
- Disconnect the battery before removing or replacing any electrical components.

## OVERVIEW

The 41000-1 Isolation Module/Control Tester performs continuity tests on three-port isolation modules for snowplow lighting systems.

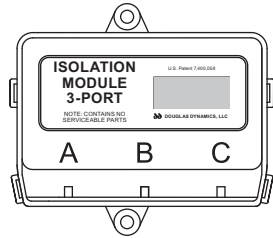

**2970-1 (green label) and 29760-1 (blue label) Isolation Modules**

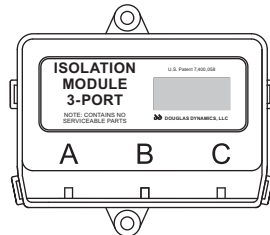

**29760-2 Isolation Module with 10-Pin Soft Start Adapter Harness**

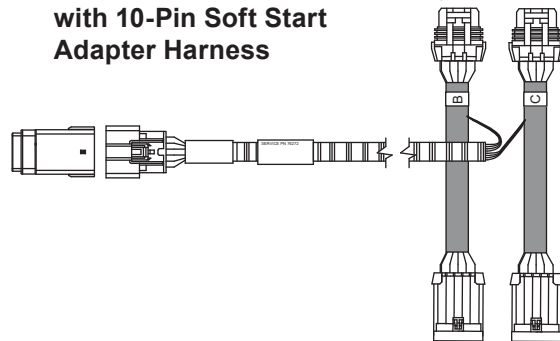

The tester simulates vehicle and snowplow low/high beam, left/right turn signal, parking light, and control power functions. It does *not* simulate any load conditions.

When the tester detects a continuity failure in the isolation module, the screen display will identify the module component that is not functioning. Record that information on your warranty claim form and Returned Material Authorization (RMA) tag.

The 41000-1 tester can also check functionality of hand-held and joystick snowplow controls. Control testing is performed manually.

The unit is protected by internal fuses. In the event of a short circuit or too much current being drawn by the isolation module, the tester will reset itself.

**There are no user-serviceable parts in the isolation module/control tester.**

## Harnesses and Power Connectors

Three harnesses are provided for connecting the 41000-1 Isolation Module/Control Tester to the component being tested.

**4-Pin Control Test Harness (Tag No. 76441)**

**6-Pin Control Test Harness (Tag No. 76446)**

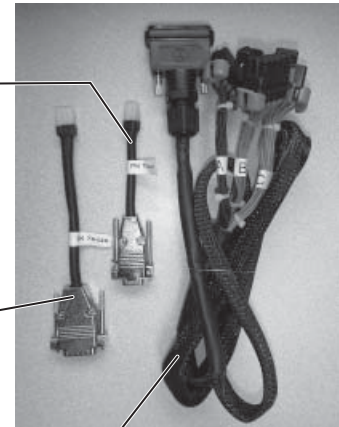

**Isolation Module Test Harness**

Three types of power connectors are provided, allowing the tester to be powered from a 110V AC outlet, the vehicle's 12V accessory power outlet, or the vehicle battery.

**110V AC Power Converter**

**Green 2-Pin Power Plug**

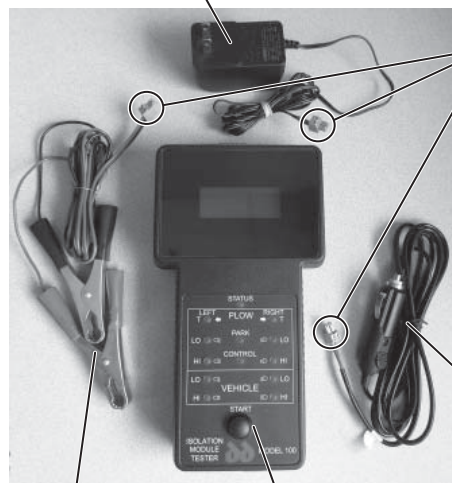

**Alligator Clips**

**Isolation Module/Control Tester**

**12V DC Power Cord**

**ISOLATION MODULE TEST – SETUP**

1. Select the preferred power connector for your testing situation:
  - Plug the transformer into a 110V AC wall receptacle.
  - Attach the alligator clips to the vehicle battery terminals: black to the NEGATIVE (-) terminal; red clip to the POSITIVE (+) terminal.\*
  - Plug the 12V DC power cord into the vehicle's 12V DC accessory power outlet.

***Do not connect the green 2-pin power plug to the tester yet.***

2. Plug the isolation module test harness 26-pin connector into the top of the tester, turning the two knobs to secure the connector.

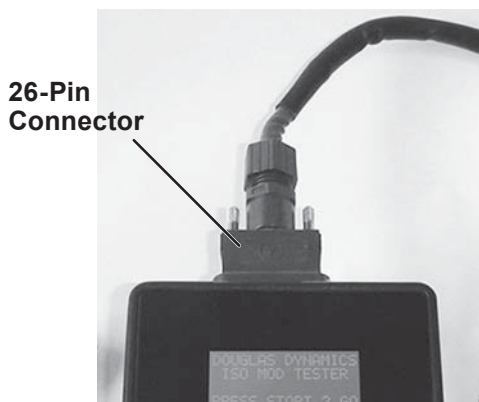

3. If the isolation module to be tested is installed in a vehicle, disconnect the harnesses from the A, B, and C ports of the module.

4. **29070-1 or 29760-1 Module:** Connect the 10-pin plugs of the isolation module test harness—labeled A, B, C—to the corresponding ports on the module.

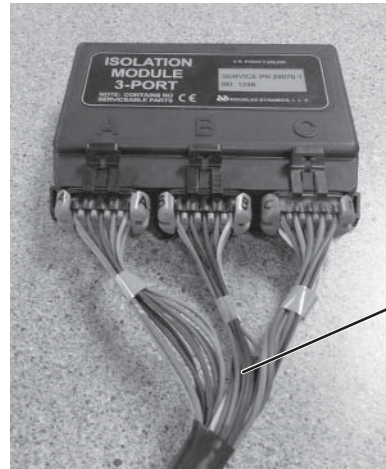

**29760-2 Module:** Connect the 10-pin soft-start adapter harness to ports B and C of the isolation module. Connect the plugs labeled B and C from the module test harness into the corresponding ports on the adapter harness. Connect the test harness plug labeled A directly to port A on the isolation module.

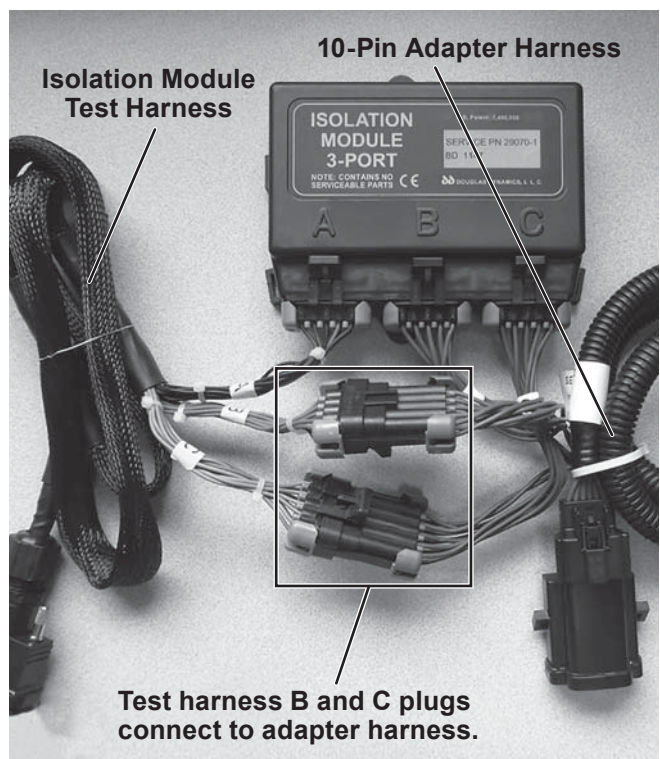

\* When disconnecting power from the tester, remove the red clip first, then the black clip.

## ISOLATION MODULE TEST – OPERATION

The tester is programmed to run several isolation module test modes. You will specify which module is being tested and choose whether the tester will run one test cycle or three.

More than one test cycle may be required to identify an intermittent failure.

### Test Modes

#### Default Test Mode

The default test mode is a single test cycle of the 29070-1 isolation module.

1. Connect the green 2-pin power plug from the power connector into the top of the tester. The STATUS LED will flash green, then red, then turn off. The start screen will appear:

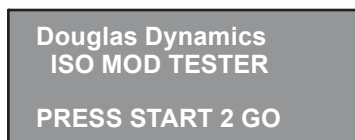

2. Press and release the START button to launch the default test cycle.

#### Selecting a Test Mode

1. Press and hold the START button while plugging the green 2-pin plug from the power connector into the top of the tester.
2. The status LED will flash green, then red, and turn off. The start screen will show briefly and the display will cycle through the test mode screens listed below. Release the START button when the desired test mode screen appears.
  - 29070-1 module, 1 test cycle
  - 29760-1 soft-start module, 1 test cycle (Also applies to 29760-2 module.)
  - 29070-1 module, 3 test cycles
  - 29760-1 soft-start module, 3 test cycles (Also applies to 29760-2 module.)

#### Example

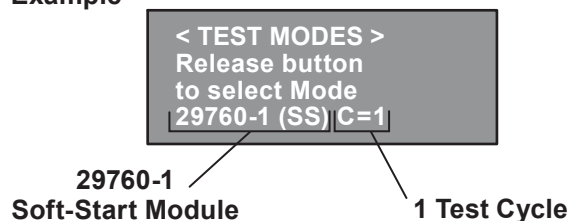

*The "Reserved Test" screens do not apply to any isolation module tests.*

3. Once the START button is released, the start screen will display again:

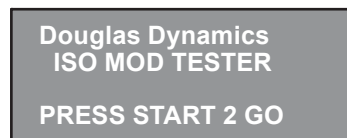

Press the START button once to begin the selected test cycle.

### Stopping/Restarting a Test Cycle

To stop a test in process, press the START button. To restart the same test from the beginning, press the START button again.

To select a different test mode, unplug the green 2-pin plug from the tester, then repeat the steps under "Selecting a Test Mode" above.

**Test Sequence**

During the test cycle, both the screen display and the LEDs on the front panel show which test is in process:

- Accessory Control Power
- Snowplow DRLs On (both L & R turn signals)  
*29070-1 module only*
- Snowplow Left Turn Signal (flash 3 times)
- Snowplow Right Turn Signal (flash 3 times)
- Snowplow DRLs Off (both L & R turn signals)  
*29070-1 module only*
- Snowplow Parking Lights On
- Snowplow Low-Beam Headlamps On
- Snowplow High-Beam Headlamps On
- Vehicle Low-Beam Headlamps On
- Vehicle High-Beam Headlamps On

**Test Results**

If no failures were detected during the test cycle, the status LED will flash green. A CYCLE PASS message will appear in the display.

When the tester detects a continuity failure, the test cycle will end and the status LED will flash red. A FAILED TEST message will appear in the display, listing which isolation module component failed and which lighting function is affected.

Record these test results and include that information on your warranty claim form and RMA tag.

**Example**

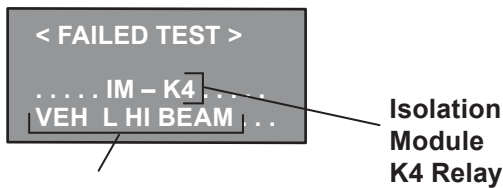

**Vehicle Left Side  
High-Beam Headlamp**

**When testing a 29760-2 soft start module,** a continuity failure may be due to a damaged or defective 10-pin adapter harness. To confirm whether the failure is occurring in the module or the harness, disconnect the 10-pin harness, plug the isolation module test harness directly into the module, as shown in Step 4 under "Isolation Module Test – Setup," and run the test cycle again.

**Isolation Module Test Codes Reference**

Display Code	Failure Type
IM – K4 LEFT HI BEAM	K4 relay Snowplow left high-beam
IM – K2 LEFT LO BEAM	K2 relay Snowplow left low-beam
IM – K3 RIGHT HI BEAM	K3 relay Snowplow right high-beam
IM – K1 RIGHT LO BEAM	K1 relay Snowplow right low-beam
IM – Q3 RIGHT TURN	Q3 transistor Snowplow right turn signal
IM – Q1 LEFT TURN	Q1 transistor Snowplow left turn signal
IM – Q2 PARKING LIGHT	Q2 transistor Snowplow parking lights (L&R)
IM – K5 CONTROL POWER	K5 relay Accessory control power
IM – DRL DRL MODE	Snowplow DRLs
IM – K4 VEH L HI BEAM	K4 Relay Vehicle left high-beam
IM – K3 VEH R HI BEAM	K3 Relay Vehicle right high-beam
IM – K2 VEH L LO BEAM	K2 Relay Vehicle left low-beam
IM – K1 VEH R LO BEAM	K1 Relay Vehicle right low-beam
..... ABORT TEST	Test stopped.
..... FAILURE NOT ID'D	Cause of failure not identified. Contact Technical Service.

## CONTROL TESTS – SETUP

If the isolation module test harness was previously plugged into the tester, disconnect it before performing a control test.

1. Select the preferred power connector for your testing situation:
  - Plug the 110V AC power converter into a 110V AC outlet.
  - Attach the alligator clips to the vehicle battery terminals: black to the NEGATIVE (–) terminal; red clip to the POSITIVE (+) terminal.\*
  - Plug the 12V DC power cord into the vehicle's 12V DC accessory power outlet.

**Do not connect the green 2-pin power plug to the tester yet.**

2. Select the appropriate control test harness (4-pin

### 4-Pin Controls

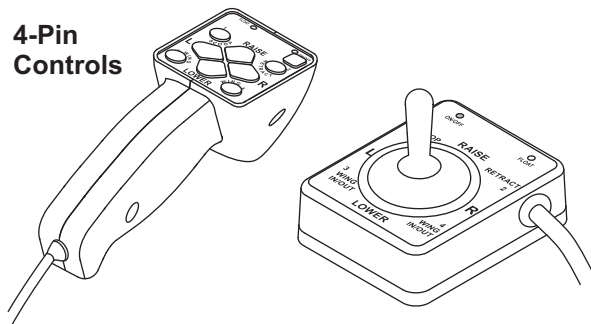

### 6-Pin Controls

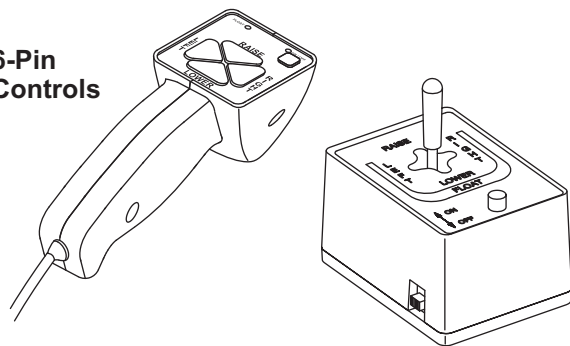

or 6-pin) for the control to be tested.

3. Plug the selected harness into the 41000-1 tester as shown and tighten the two knurled screw posts.

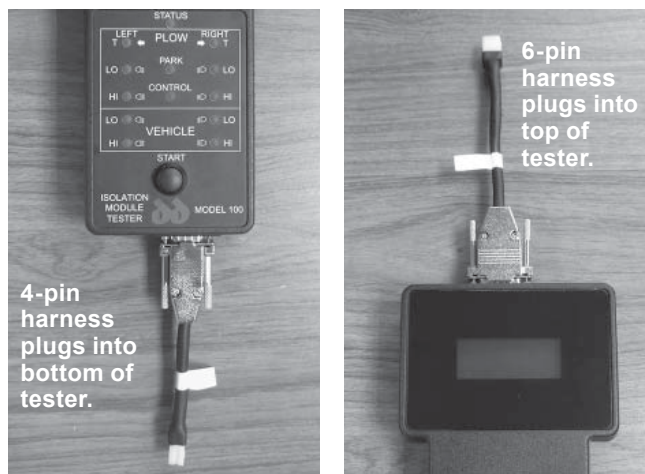

**Do not connect the control to the control test harness yet.**

\* When disconnecting power from the tester, remove the red clip first, then the black clip.

## CONTROL TESTS – OPERATION

The test cycle is operated manually, by pressing each control button or moving the control joystick to each position ("RAISE," "LOWER," etc.) in sequence. The tester displays a confirming screen for each function in turn as it receives communications from the control.

Control test results are shown on the LCD display only. The 13 LEDs on the face of the tester are not used for the control tests. Disregard any LEDs that illuminate during the 6-pin control test.

### 4-Pin Control Test (Reserved Test–X)

1. Plug the control into the 4-pin jack on the 76441 control test harness previously connected to the tester.
2. Plug the green 2-pin plug from the power connector into the top of the tester.

The status LED on the control face will FLASH green, THEN red, and then turn off. The ON/OFF light on the control will not illuminate, but on a hand-held control the buttons will be backlit.

The tester will display the MUX POWER ON screen, confirming a successful initial connection:

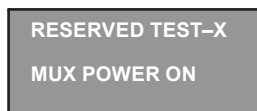

3. Press the ON/OFF button on a hand-held control, or slide the ON/OFF switch on a joystick control, to turn the control ON. The red ON/OFF light on the control will illuminate.

**If the red light flashes**, there is a communication error between the control and the tester. Repeat Steps 1–3 using a known functional control.

- If the red light then comes on without flashing, the problem is in the original control. Note the flashing red light on the RMA tag and warranty claim.
- If the red light still flashes when a known functional control is attached, the problem is in the control test harness or the tester itself. Call Technical Service.

4. The 4-pin control test start screen will appear, confirming that the control's ON button has been pressed:

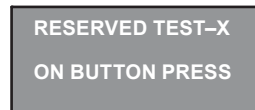

5. To run the control test, activate the snowplow functions in sequence as described in Steps 6–14. The tester will confirm each function by displaying the corresponding screen—RAISE, LEFT, LOWER, etc.—while the function button is being pressed or the joystick is being held in position.

As the control button or joystick is released between testing steps, the display screen will revert to a generic test screen:

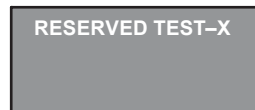

*When the tester detects a communication failure, it will continue to display the generic screen instead of moving on to the next function screen. Note that information on your RMA tag and warranty claim form.*

To resume testing, go to the next step in the sequence.

6. Press and hold the RAISE button on a hand-held control, or hold the joystick to the "RAISE" position on the joystick control. The RAISE screen will display until the button/joystick is released:

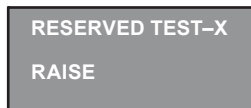

7. Press and hold the L button on the hand-held control, or hold the joystick in the "L" position on the joystick control. The LEFT screen will display until the button/joystick is released:

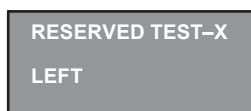

8. Repeat Step 7, this time selecting the R button or "R" joystick position for the angle right function.

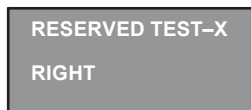

9. *Press and release* the LOWER button, or move the joystick to the "LOWER" position *and release it*. The LOWER screen will appear on the display:

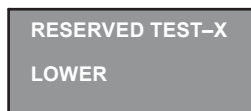

10. To test the FLOAT function: *Press and hold* the LOWER button, or *hold the joystick lever in the "LOWER" position*, for longer than 1 second, then release. The green FLOAT light on a hand-held control will illuminate.

For both controls, the LOWER screen will continue to display until the RAISE button is pressed or the joystick is moved to the "RAISE" position to revert the display to the generic test screen.

11. Press and hold the SCOOP button, or hold the joystick in the "SCOOP" position. The SCOOP – 1 screen will display until the button/joystick is released:



12. Repeat Step 11, this time selecting RETRACT on the control.

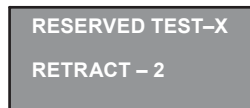

13. Press and hold the left WING button, or hold the joystick in the left "WING IN/OUT" position. The WING – L screen will display until the button/joystick is released:



14. Repeat Step 13, this time selecting the right WING button or right "WING IN/OUT" position on the control.



### Testing Multiple 4-Pin Controls

To test another 4-pin control, disconnect the current control from the test harness and attach the next control to be tested. The display will revert to the MUX POWER ON screen shown in Step 2.

Begin the next test sequence at Step 3.

### 6-Pin Control Test (Reserved Test-1)

1. Press and hold the tester START button while plugging the green 2-pin plug from the power connector into the top of the tester.
2. The status LED on the face of the tester will flash green, then red, and then turn off. The start screen will show briefly and the display will cycle through the test mode screens. Release the START button when the RESERVED TEST-1 selection appears:

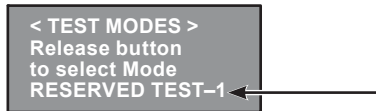

3. Plug the control into the 6-pin jack on the 76446 test control harness previously connected to the tester. The ON/OFF light on the control will not illuminate, but on a hand-held control the buttons will be backlit.
4. Press the START button on the tester. The 6-pin control test start screen will appear:

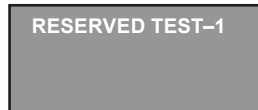

5. Press the ON/OFF button on the hand-held control, or slide the ON/OFF switch on the joystick control, to turn the control ON. The red ON/OFF light on the control will illuminate.

6. To run the test, press the plow function buttons (hand-held control) or move the joystick (joystick control) in sequence as described in Steps 7–10. The tester will confirm each function by displaying the corresponding screen—RAISE, LEFT, LOWER, etc.

As the control button or joystick is released between testing steps, the display screen will revert to the start screen shown in Step 4.

*When the tester detects a communication failure, it will continue to display the start screen instead of moving on to the next confirming screen. Note that information on your RMA tag and warranty claim form.*

To resume testing, go to the next step in the sequence.

7. Press and hold the RAISE button, or hold the joystick in the "RAISE" position. The MOTOR ON/RAISE BUTTON screen will display until the button/joystick is released:

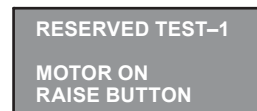

There is an approximate 6-second timeout if the RAISE button is held longer than 6 seconds. The display will clear, as shown in Step 4.

8. *Press and release* the LOWER button, or move the joystick to the "LOWER" position *and release it*. The LOWER BUTTON screen will appear on the display:



9. To test the FLOAT function: Press and hold the LOWER button, or hold the joystick lever in the "LOWER" position, for 1/2 second or longer, then release. The green FLOAT light on a hand-held control will illuminate. For both controls, the LOWER screen will continue to display.
10. Press and hold the LEFT button on the hand-held control, or hold the joystick in the "LEFT" position. The MOTOR ON/LEFT BUTTON screen will display until the button/joystick is released:

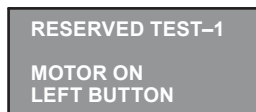

11. Repeat Step 7, this time selecting the RIGHT button or "RIGHT" joystick position.

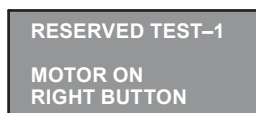

12. The tester may not correctly identify a LEFT button press if not in the FLOAT mode.
13. Timeout mode will release if LEFT/RIGHT button is pressed for more than 9 seconds. The display will clear, leaving the display as shown in Step 4 or Step 8.

### Testing Multiple 6-Pin Controls

To test another 6-pin control, disconnect the current control from the test harness and attach the next control to be tested. The display will revert to the "Reserved Test-1" screen from Step 4.

Begin the next test sequence at Step 5.

The company reserves the right under its product improvement policy to change construction or design details and furnish equipment when so altered without reference to illustrations or specifications used. This equipment manufacturer or the vehicle manufacturer may require or recommend optional equipment for snow removal. Do not exceed vehicle ratings with a snowplow. The company offers a limited warranty for all snowplows and accessories. See separately printed page for this important information.

**Printed in U.S.A.**

---