

# 33208 MOUNT KIT

Toyota Tundra

2022-\_\_

## Installation Instructions

**⚠ CAUTION**

Read this document before installing the snowplow.

**⚠ CAUTION**

See your sales outlet/website for specific vehicle application recommendations before installation. The online selection system has specific vehicle and snowplow requirements.

SAFETY DEFINITIONS

**⚠ WARNING**

Indicates a potentially hazardous situation that, if not avoided, could result in death or serious personal injury.

**⚠ CAUTION**

Indicates a potentially hazardous situation that, if not avoided, may result in minor or moderate injury. It may also be used to alert against unsafe practices.

**NOTE:** Indicates a situation or action that can lead to damage to your snowplow and vehicle or other property. Other useful information can also be described.

WARNING/CAUTION & INSTRUCTION LABELS

Become familiar with and inform users about the warning/caution and instructions labels on the back of the blade.

**NOTE:** If labels are missing or cannot be read, see your sales outlet.

**NOTE :** Translated safety labels are available. Please contact your sales outlet.

Warning/ Caution Label



Instruction Label

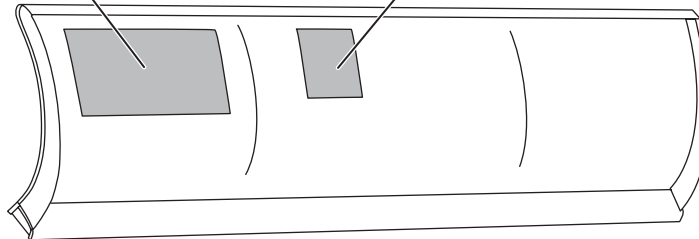

## SAFETY PRECAUTIONS

Improper installation and operation could cause personal injury and/or equipment and property damage. Read and understand labels and the Owner's Manual before installing, operating, or making adjustments.

### **⚠ WARNING**

**Lower the blade when the vehicle is parked. Temperature changes could change hydraulic pressure, causing the blade to drop unexpectedly or damaging hydraulic components. Failure to do this could result in serious personal injury.**

### **⚠ WARNING**

**The driver shall keep bystanders clear of the blade when it is being raised, lowered, or angled. Do not stand between vehicle and blade or within 8 feet of a moving blade. A moving or falling blade could cause personal injury.**

### **⚠ WARNING**

**Keep hands and feet clear of the blade and A-frame when mounting or removing the snowplow. Moving or falling assemblies could cause personal injury.**

### **⚠ WARNING**

**Do not exceed GVWR or GAWR including the blade and ballast. The rating label is found on the driver-side vehicle door cornerpost.**

### **⚠ WARNING**

**To prevent accidental movement of the blade, always turn the control OFF whenever the snowplow is not in use. The power indicator light will turn OFF.**

### **⚠ WARNING**

**Remove blade assembly before placing vehicle on hoist.**

### **⚠ CAUTION**

**Refer to the Quick Match tool for minimum vehicle recommendations and ballast requirements.**

## PERSONAL SAFETY

- Remove ignition key and put the vehicle in PARK or in gear to prevent others from starting the vehicle during installation or service.
- Wear only snug-fitting clothing while working on your vehicle or snowplow.
- Do not wear jewelry or a necktie, and secure long hair.
- Wear safety goggles to protect your eyes from battery acid, gasoline, dirt, and dust.
- Avoid touching hot surfaces such as the engine, radiator, hoses, and exhaust pipes.
- Always have a fire extinguisher rated BC handy, for flammable liquids and electrical fires.

## FIRE AND EXPLOSION

### **⚠ WARNING**

**Gasoline is highly flammable and gasoline vapor is explosive. Never smoke while working on vehicle. Keep all open flames away from gasoline tanks and lines. Wipe up any spilled gasoline immediately.**

Be careful when using gasoline. Do not use gasoline to clean parts. Store only in approved containers away from sources of heat or flame.

## CELL PHONES

A driver's first responsibility is the safe operation of the vehicle. The most important thing you can do to prevent a crash is to avoid distractions and pay attention to the road. Wait until it is safe to operate mobile communication equipment such as cell phones, text messaging devices, pagers, or two-way radios.

## VENTILATION

### **⚠ WARNING**

**Vehicle exhaust contains lethal fumes. Breathing these fumes, even in low concentrations, can cause death. Never operate a vehicle in an enclosed area without venting exhaust to the outside.**

**NOISE**

Airborne noise emission during use is below 70 dB(A) for the snowplow operator.

**VIBRATION**

Operating snowplow vibration does not exceed 2.5 m/s<sup>2</sup> to the hand-arm or 0.5 m/s<sup>2</sup> to the whole body.

**TORQUE CHART**

**⚠ CAUTION**

**Read instructions before assembling. Fasteners should be finger tight until instructed to tighten according to the torque chart. Use standard methods and practices when attaching snowplow, including proper personal protective safety equipment.**

<b>Recommended Fastener Torque Chart</b>					
<b>Inch Fasteners Grade 5 and Grade 8</b>					
Size	Torque (ft-lb)		Size	Torque (ft-lb)	
	Grade 5	Grade 8		Grade 5	Grade 8
1/4-20	8.4	11.9	9/16-12	109	154
1/4-28	9.7	13.7	9/16-18	121	171
5/16-18	17.4	24.6	5/8-11	150	212
5/16-24	19.2	27.3	5/8-18	170	240
3/8-16	30.8	43.6	3/4-10	269	376
3/8-24	35.0	49.4	3/4-16	297	420
7/16-14	49.4	69.8	7/8-9	429	606
7/16-20	55.2	77.9	7/8-14	474	669
1/2-13	75.3	106.4	1-8	644	909
1/2-20	85.0	120.0	1-12	704	995

<b>Metric Fasteners Class 8.8 and 10.9</b>					
Size	Torque (ft-lb)		Size	Torque (ft-lb)	
	Class 8.8	Class 10.9		Class 8.8	Class 10.9
M6 x 1.00	7.7	11.1	M20 x 2.50	325	450
M8 x 1.25	19.5	26.9	M22 x 2.50	428	613
M10 x 1.50	38.5	53.3	M24 x 3.00	562	778
M12 x 1.75	67	93	M27 x 3.00	796	1139
M14 x 2.00	107	148	M30 x 3.50	1117	1545
M16 x 2.00	167	231	M33 x 3.50	1468	2101
M18 x 2.50	222	318	M36 x 4.00	1952	2701

These torque values apply to fasteners except those noted in the instructions.

**INSTALLATION INSTRUCTIONS**

**NOTE: For easier assembly and installation, vehicle and all snowplow components should be on a smooth, level, hard surface, such as concrete.**

1. Remove the grill and bumper assembly. Retain the fasteners for reinstallation.
2. With the grill and bumper assembly removed, unplug and unclip the connection for the motor to the active air dam. Place the cable out of the way to ensure that no snags or pinched cables occur in the following steps.

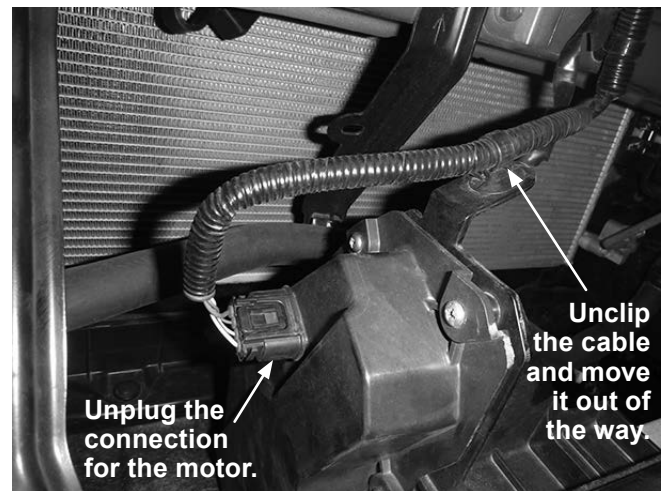

3. Remove the eight fasteners that secure the aluminum bumper bar and carefully remove the bumper and active air dam assembly.

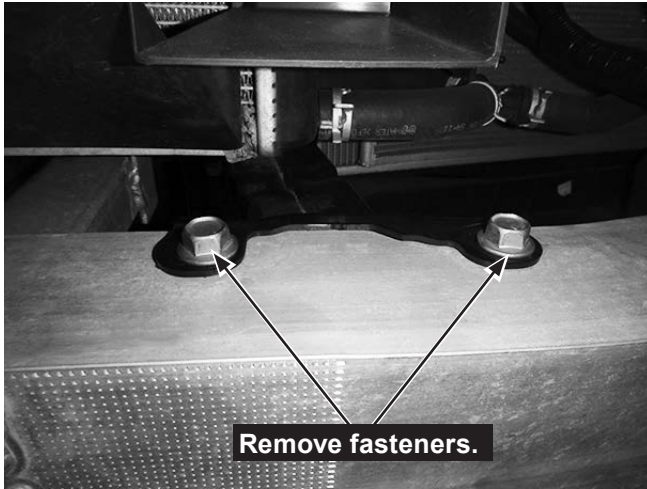

4. Remove the two hinges for the air dam from the brackets on the bumper bar.

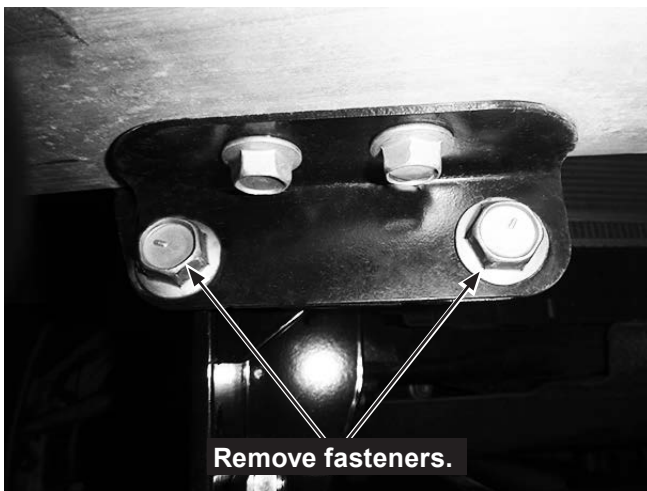
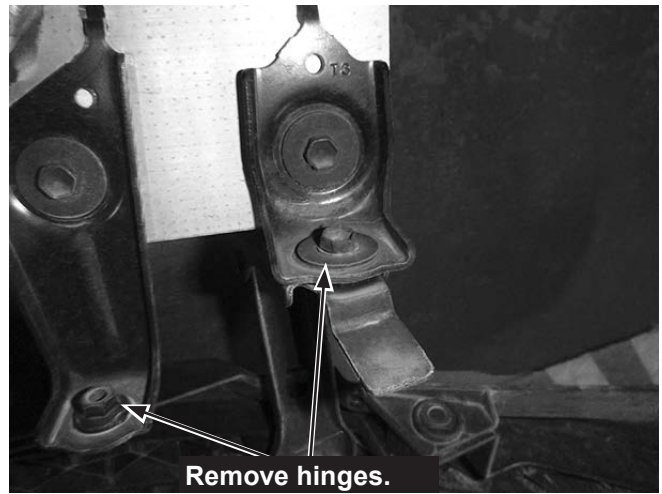

5. Remove the two fasteners attaching the arm to the air dam.

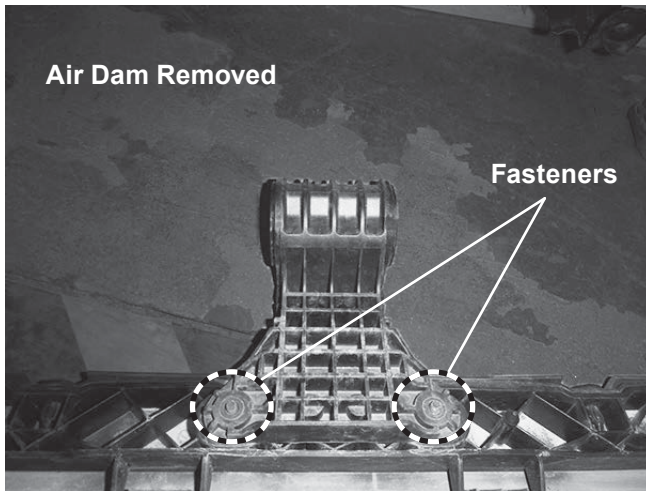

6. Once the air dam is removed from the arm, mark and cut the arm as shown so it won't interfere with the mount once installed.

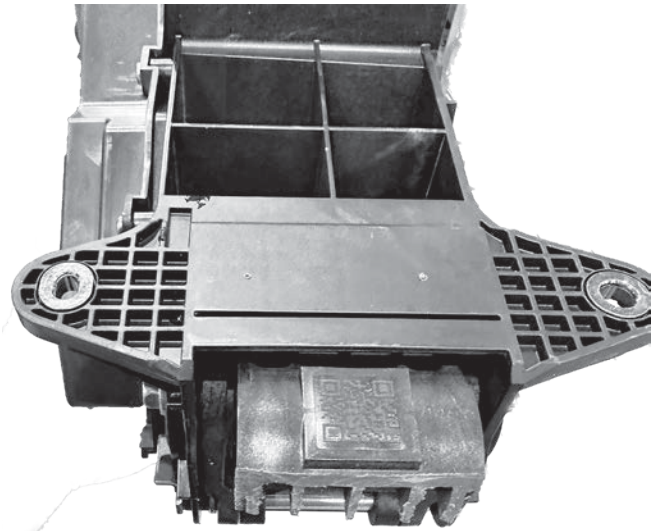

7. On the passenger's side of the frame, place the passenger-side mount assembly against the frame. Insert one 1/2" x 1-1/2" cap screw with a 1/2" washer through the front hole of the frame and mount assembly. Secure it with a 1/2" locknut hand tightened to help hold mount assembly in place.

- Place one 7" handled 1/2" x 1-1/2" cap screw through the rear hole of the frame and mount assembly. Mark the handle inside the plate on the end of the frame rail and cut the handle to length so that it does not protrude through the frame rail. Once the handle is cut to length, place a 1/2" washer on the handled cap screw and insert it back through the rear hole. Place one 1/2" x 1-1/2" cap screw and washer through the front hole. Secure both fasteners with a 1/2" locknut.

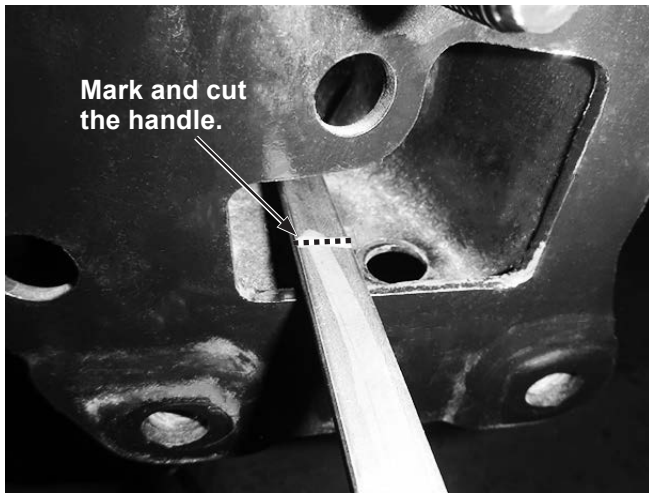

- Tighten both locknuts until they are snug, but do not torque them at this time.

**⚠ CAUTION**

Use caution not to pinch, cut, or drill through any wires or hoses running along the frame rail.

- Ensure that the mount assembly is against the side of the frame rail. Using the holes in the mount as a guide, drill the three 1/2" holes in the frame.

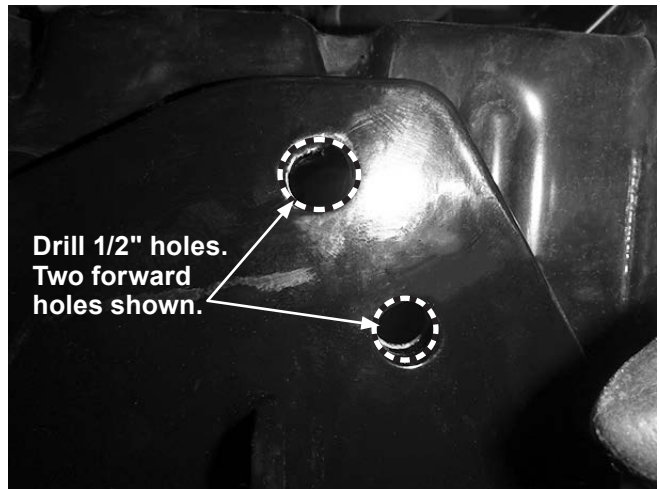

- Place a 1/2" washer on each of two 7" handled 1/2" x 1-1/2" cap screws. Insert the cap screws with washers through the two forward drilled holes and secure each one with a 1/2" locknut. Hand tighten.



- Place one 1/2" washer on an 18" handled 1/2" x 1-1/2" cap screw. Insert the bolt on handle through the frame and rear hole of the mount assembly. Place the stiffener arm over the rear fastener with the bent flange pointing under the frame rail. Insert a 1/2" x 1-1/2" cap screw through the lower hole of the stiffener arm and mount assembly. Secure both fasteners with 1/2" locknuts. Hand tighten.

**NOTE: If the Sway Bar interferes, Stiffener Arm can be flipped and one of the top two holes can be used for installation. Refer to picture below.**

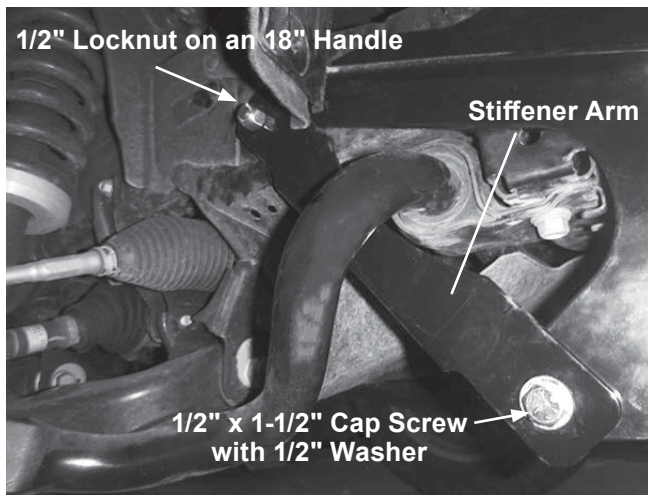

- Secure all cap screws with hand-tightened 1/2" locknuts. Repeat Steps 7–12 on the driver's side of vehicle.
- Secure mount beam to the bottom set of adjustment holes. Start by securing bottom rear adjustment holes with two 1/2" x 1 1/4" cap screws. Then using supplied 7" handled 1/2" x 1-1/2" cap screws for the top rear holes. Finish securing mount beam with remaining six 1/2" x 1 1/4" cap screws and capture with 1/2" locknuts.

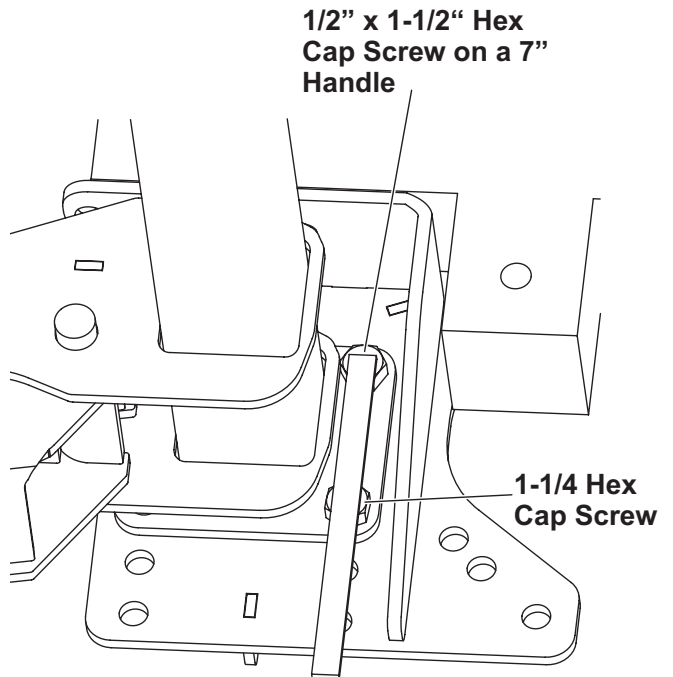
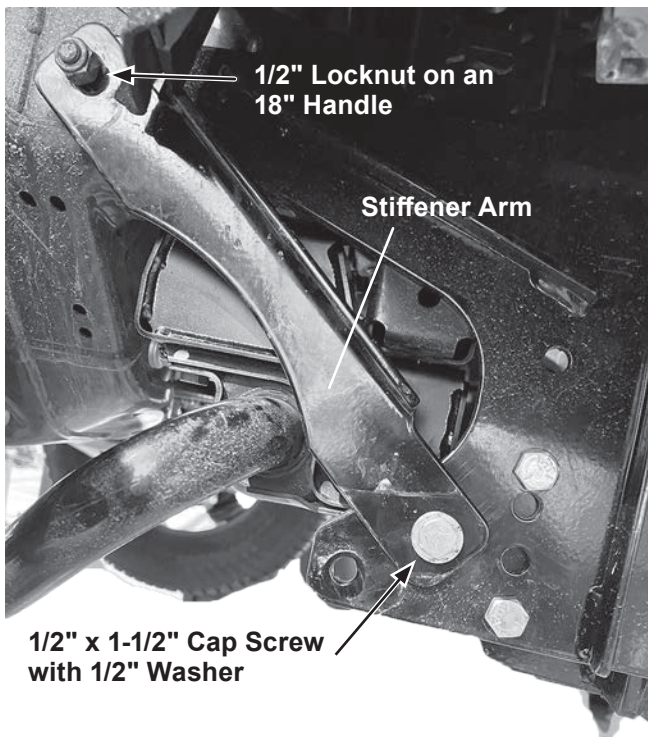
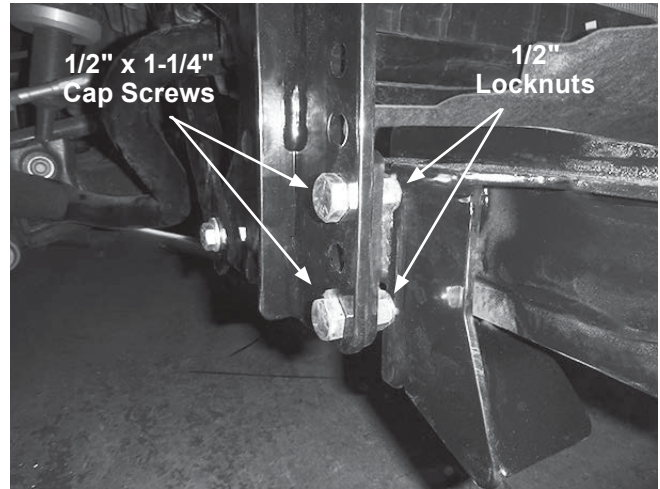

**NOTE: Handles may be bent or trimmed for easier access or extra material.**

15. Install the receivers and ensure that the ground height of each receiver is between 13"–16" from the top edge of the receiver to the ground. If the height is less than or close to 13", adjust the mount beam to the next height adjustment holes.

---

**NOTE: Trimming of the lower plastic bumper section may be necessary when using the upper hole sets to establish correct beam height.**

---

16. Tighten all fasteners according to the torque chart.
17. When reassembling the bumper structure, use two of the supplied M12 washers as spacers for the bottom outside fasteners of the aluminum bumper bar to avoid interference with the mount when fully tightened.

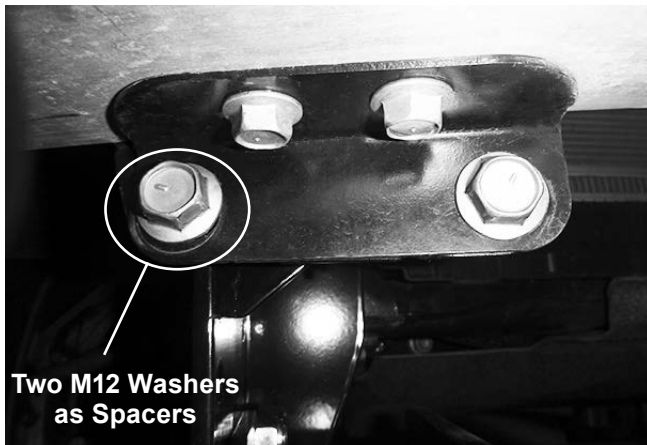

18. Reconnect the active air dam cable that was disconnected in step 2 and secure the cable in its original location.

---

**NOTE: After five to ten hours of snowplow usage, retorque all push plate assembly fasteners.**

---

---

**NOTE: It may be necessary to disable the PCS (Pre-Collision System) and other driver support systems when operating the vehicle with a snowplow attached. See vehicle owner's manual for more information.**

---

The company reserves the right under its product improvement policy to change construction or design details and furnish equipment when so altered without reference to illustrations or specifications used. This equipment manufacturer or the vehicle manufacturer may require or recommend optional equipment for snow removal. Do not exceed vehicle ratings with a snowplow. The company offers a limited warranty for all snowplows and accessories. See separately printed page for this important information.

**Printed in U.S.A.**