



220C

Volumetric Meter Composite Body Protected Dial - Class C, Reed and HRI AMR pre-equipment

The 220C meter has been specially designed for operators anxious to improve the reliability and meter efficiency of their networks. The 220C piston meter benefits from Sensus' long experience in the manufacture of high-performance meters.

The 220C design meets particularly the requirements of markets with high expectations. Theft of the meter is discouraged by its design without a brass body. Its tamperproof design assures at any time the correct reading of the actual water consumption and its super strong composite body makes its installation safe, even in a tropical environment.

The dial is housed in a case filled with lubricant which means it is protected from any impurities in the network. It can be read perfectly under all conditions and is not affected by fogging or the build up of algae.

Through its dual AMR pre-equipment, with both Reed and HRI interfaces, the 220C can be used in any network where a reliable and cost effective AMR system is required. Both AMR solutions are retrofittable and can be added at any time after the meter has been installed.

MAIN FEATURES

- DN15, PN16
- Ultra light and easy to handle
- Accuracy better than class C requirements
- Conforms to the latest OIML standard
- Pre-equipped as standard for both Reed and HRI AMR interfaces
- Tamperproof design
- Designed for tropical installation conditions
- Extreme resistance to water hammer

Approvals

- OIML R-49-1/2/3:2006
- SANS 1529-1:2006

Meter Design

The 220C body, made of a composite material based on a polymer with glass fibres, provides exceptional strength and weathering behaviour.

Special attention has been paid to the strength of the threads ensuring that the meter may be installed in existing installations without the danger of thread damage.

Reliability

Thanks to the use of the composite body with generous wall thickness the 220C meter offers high protection against weathering, water hammer and accidental heat exposure. The meter will retain all its mechanical properties irrespective of the installation environment.

The internal components, made of high-grade polymers, have been designed to preserve the initial performance of the meter for many years of operation. All materials are suitable for potable water and won't affect the organoleptic properties of drinking water.

Available Options

- HRI electronic sensor (Data Unit, Pulse Unit)
- Reed switch
- Connectors
- Non-return valve
- Inline strainer

220C

Volumetric Meter Composite Body, Protected Dial - Class C, Reed and HRI AMR pre-equipment

Typical Headloss Curve

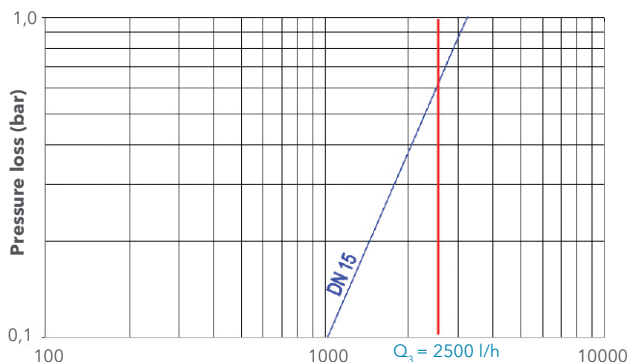

Typical Error Curve

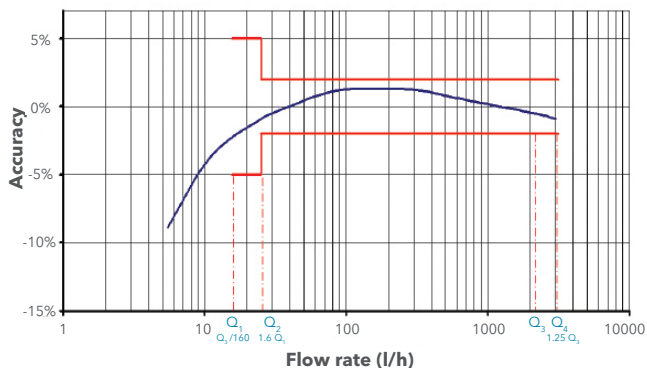

Metrological Characteristics (OIML Recommendation R49/ 1 to 3 (2006))

Nominal size	DN	mm	15
Permanent flowrate	Q_3	m^3/h	2.5
Ratio	Q_3 / Q_1		160
Overload flowrate	Q_4	m^3/h	3.125
Minimum flowrate (tolerance $\pm 5\%$)	Q_1	l/h	15.6
Transitional flowrate (tolerance $\pm 2\%$)	Q_2	l/h	25.0

Operational Characteristics (manufacturer's data)

Nominal size	DN	mm	15
Starting flowrate		l/h	1-3
Minimum flowrate		l/h	6
Transitional flowrate		l/h	15
Maximum registration		m^3	10^4
Lowest resolution		l	0.02
Pressure loss at Q_3		bar	0.6
Pressure Class	PN	bar	16

Dimensions and Weights

Nominal size	DN	mm	15
Length	L	mm	115 ⁽¹⁾
Width	W	mm	105
Total height	H	mm	110.5
Total height with assembled HRI	TH	mm	132.3
Height to pipe axis	h	mm	50.0
Piping dimension		inch	$\frac{1}{2}$
Tail		inch	$G\frac{3}{4}"B$
Piece	Diameter	mm	26.44
Thread	Pitch		1.814
Weight		kg	0.5

⁽¹⁾ For other dimensions contact your sales office

Dimension Pictures

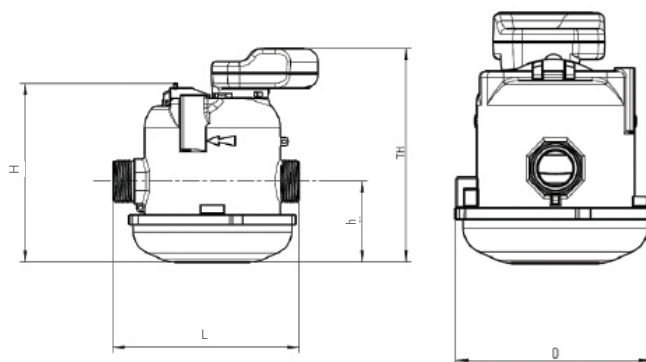

Tampering protection

A key requirement in the design of the 220C meter was to produce a tamper-proof meter:

- Having no magnetic transmission, the meter is not affected by external magnets placed near the meter.
- The use of a robust composite body combined with a thick polycarbonate window prevents any mechanical tampering (commonly through the use of a screw-clamp or a hot needle).
- Meter sealing is achieved by means of a non-removable plastic seal. Provision is made for an optional wire and lead seal.

220C

Volumetric Meter Composite Body, Protected Dial - Class C, Reed and HRI AMR pre-equipment

AMR Options

The 220C meter can be equipped with either a reed switch and/or with the Sensus advanced HRI modules. Both interfaces can be fitted in the field on already installed water meters or ordered factory fitted to the meter.

The Reed switch guarantees a cost effective pulse output with a pulse resolution of 2 pulses/litre.

For more advanced applications the 220C can be equipped with a HRI module. Some of the advantages of the HRI module are:

- Detection of reverse flow and therefore exact remote duplication of the counter reading.
- The inductive interface does not suffer from reed switch bounce and, unlike a reed switch; the pulse output is not affected by magnets placed near the meter.
- The pulse value is programmable.

There are two main variants of HRI:

1. HRI Pulse Unit (A-version)

This gives a pulse output which can be used for reliable counting of the volume.

2. HRI Data Unit (B-version)

The HRI Data Unit is a data interface which supplies serial output according M-Bus standard EN13757 which can be connected to M-Bus converters.

The serial interface can also be used to configure a pulse output. This pulse output can be used alternatively to the serial output.

For more information please refer to the HRI datasheet.



Register

The register's roller counter is immersed in a lubricant, ensuring optimum operation and protection. This technique prevents any condensation and enables perfect legibility of the counter under all conditions, irrespective of the water quality.

The counter is protected by a very thick polymer dial face designed to withstand environmental influences without cracking or discolouring.



Installation and Maintenance Instructions

1. The meter may be installed horizontally, vertically or at an any angle without loss of accuracy
2. The installation of upstream and downstream valves is recommended to facilitate maintenance of the meter
3. Flush the pipe work thoroughly to clear all impurities
4. Remove the two caps protecting the threads and place washers with connectors (not supplied) on the two ends
5. Check the direction of flow through the meter by the arrow on the body. Ensure that the meter is installed appropriately
6. First tighten the inlet nut on the meter by hand
7. Fit and tighten by hand the nut on the outlet. Tighten both nuts with a spanner using minimal force
8. Open the upstream stop-valve slowly and then completely; then draw water at intervals
9. Check for flow through the meter and check for leakage at the connections



Sensus South Africa (Pty) Ltd | Plumbago Business Park, 3A Spier Street, Glen Erasmia, Kempton Park | South Africa | +27 11 966 9300 | sales.za@xylem.com | sensus.com

©2020 Sensus. All products purchased and services performed are subject to Sensus' terms of sale, available at [sensus.com](https://www.sensus.com). Sensus reserves the right to modify these terms and conditions in its own discretion. The Sensus logo and other Sensus products or services referenced are registered trademarks of Sensus.

This document is for informational purposes only, and SENSUS MAKES NO EXPRESS WARRANTIES IN THIS DOCUMENT. FURTHERMORE, THERE ARE NO IMPLIED WARRANTIES, INCLUDING WITHOUT LIMITATION, WARRANTIES AS TO FITNESS FOR A PARTICULAR PURPOSE AND MERCHANTABILITY. ANY USE OF THE PRODUCTS THAT IS NOT SPECIFICALLY PERMITTED HEREIN IS PROHIBITED.