

FM-2D/K

Frequency Converter Flow-totalization of 2 water meters



Description

The FM-2D/K is a μ P-controlled frequency converter with two pulse inputs. It can be applied in linking the signals of two input pulses with flow direction signals.

Application

- Flow accumulation
- Forward and reverse totalization
- Flowrate indicator
- Monitoring of limit values
- Remote reading
- Remote transmission
- Dosing
- Automation
- For single or compound meters

Main Features

- Two freely programmable pulse outputs with flow direction processing
- Variable pulse provider types connectable
- Current output freely scaleable and separated for forward and reverse flow
- Output for current type with direction identification (-20 mA...+20 mA)
- Separate relay outputs for forward and reverse volumes
- 2 Opto-coupler outputs used for pulses and direction signals or limit value 1 and limit value 2
- Pulse divisor for pulse output, adjustable
- Integrated LC-Display for the display of volume, momentary flowrate and programming data
- M-Bus data connection for reading of instant values
- Programmed data is retained after power failure
- Galvanic isolation from supply, entry and output
- Programmable on site by 5 buttons
- Test mode as installation help
- Housing equipped for wall or top hat railing

Description of symbols

Symbols

- Loop programming
- Loop reading of programming values
- Loop reading of meter values
- Loop reading of statistics values

Symbols of status line (bottom line)

- A Loop programming
- B Loop reading programming data
- C Loop reading meter values
- D Loop statistics values
- Programming data stored
- Programming data can be changed
- Σ Summation of pulse inputs
- Δ Subtraction of pulse inputs
- E Π Choice of sensor type
- E1 = Π Pulse value sensor 1
- E2 = Π Pulse value sensor 2
- + - 100 Qmax (corresponds to 20mA)
- + - Current output and damping
- Λ Λ \square Π Limit switches and hysteresis
- $\square = \Pi$ Pulse value Optocoupler output
- 0 = \square Start index
- $_ = \Pi$ Pulse value and status of relais output
- K = ? Optocoupler output
- Test Test mode
- + - Reading balanced volume and current flowrate
- Reading balanced volume
- + - Reading current flowrate
- R Reading reverse volume
- + - \uparrow Extreme value Maximum (resetable)
- + - \downarrow Extreme value Minimum (resetable)
- + - \uparrow 1 Extreme value Maximum 3 hour value
- + - \downarrow 1 Extreme value Minimum 3 hour value
- \times upper limit is passed
- \times lower limit is passed
- \times current value is within the limits
- \oplus Display of active buttons

Connection diagram

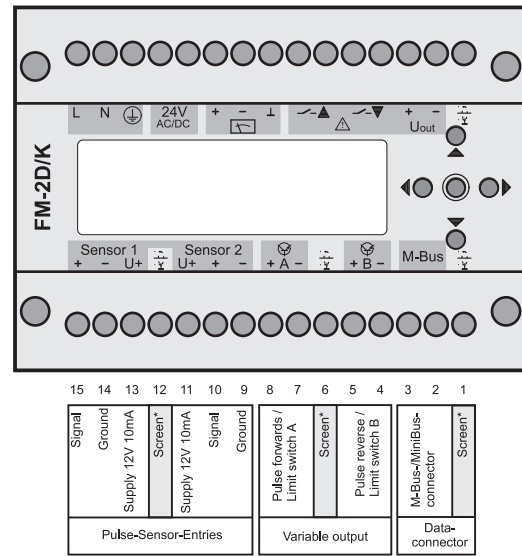
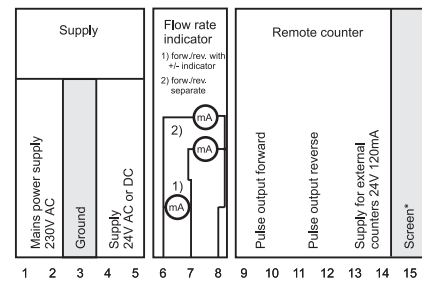

Connection examples

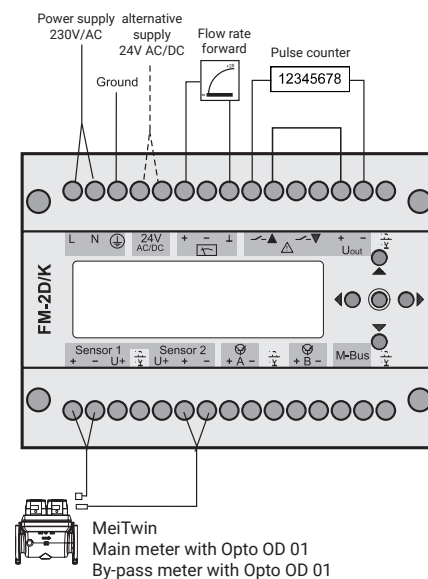
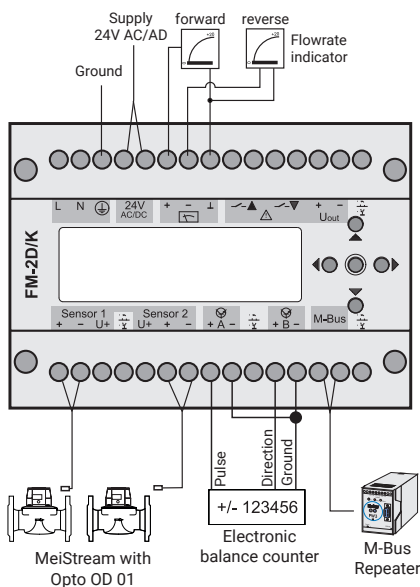

Menu structure

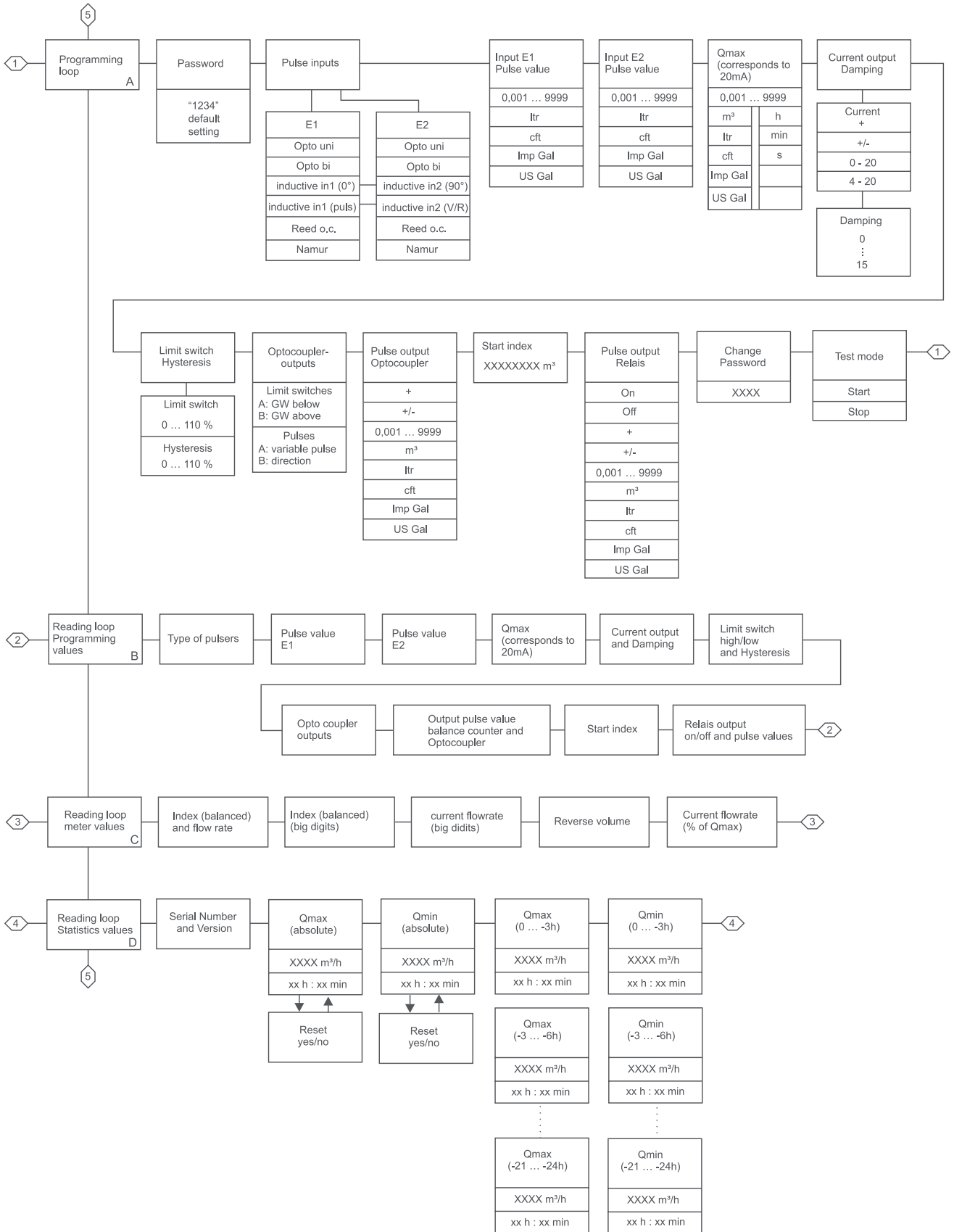

Technical data

Power supply

230 V AC (209...253 V), 24 V DC (20...27 V),
24 V AC (17...27 V)

Power consumption

8 VA

Dimensions

100 x 73 x 124 mm (W x H x D)

Weight

approx. 650 g

Protection class

Housing: IP 40

Terminals: IP 20

Temperature range

operation: 0 ... +50 °C

storage: -10 ... + 80 °C

Input

Universal sensor input for Opto-pulser (EN 60947-5-6), Reed- and open-collector-pulser

8.2 V, approx. 1kOhm

Auxiliary voltage for feeding 3-wire sensor

12 V, 10 mA

Input frequency range

0 ... 300 Hz

(0 ... 150 Hz Flow direction identification)

Maximum cable length

approx. 6 km

(depending on cable quality and pulser type)

Contact bounce suppression

automatic

(depending on the input frequency and sensor type)

Output

Current output

0 ... 20 mA or 4 ... 20 mA (selectable)

Load

max. 1000 Ohm (at nominal supply voltage)

(max. 700 Ohm with connected 3-wire pulser)

Response time

16 step selectable

(no damping = 0, max. damping = 15)

Max. transmission distance

approx. 14 km at 500 Ohm-load with a cable cross
section of 1 mm²

Relay pulse output

Dry contact (no internal voltage supplied)

Max. switching voltage (external): 48 V AC/DC

Max. switching current: 1 A

Contact closure time: 400 ms

Max. switching frequency: 1 Hz

Pulse value freely selectable

Max transmission distance

approx. 500 m with direct connection

approx. 12 km with transistor relay

Opto-coupler outputs

max. 30 V, 30 mA, 150 mW, digit pulse 500 µs
transmitted

Direction and limiting value continuous contact

M-Bus output

in compliance with EN 13757-3

Display

Liquid crystal display (LCD)

- Momentary flowrate
- Counter reading
- 8 Maximum-values (3 hour interval of the last 24 hours); resetable
- 8 Minimum-values (3 hour interval of the last 24 hours); resetable

Programming data

- Flowrate range
- Input pulse validity
- Output pulse validity
- Standardized current range 0/4 ... 20 mA
- Response time (16-levels)
- Limit value

Calibration

5-input keys used in conjunction with LCD,
configurable program protection

Lightning protection

To protect the device from voltage surges caused by
lightning, installation of lightning protection devices is
recommended.

Intrinsic safety

If the water meter / pulser is to be installed in a
hazardous area the FM-2D/K must be installed in a
safe area with the pulser inputs isolated by means of
suitable transistor relays.