

# ROCKBOOK-1400



Windows



IP65



GPS



Camera



Dual-battery



Fingerprint



NFC



4G/5G



WIFI



Bluetooth

## Performance

- 12th Gen Intel Core™ i5/i7 processor

- Intel® Iris® Xe Graphics eligible

- Support Windows 11/10 OS

## Communication

- Highspeed Wi-Fi6

- Support M.2 interface 5G/4G selection

- Bluetooth 5.1 for higher transfer speeds

## Function

- 14-inchFHD, Optional touch screen, Backlit Keyboard

- Rich interfaces and extended function can meet various needs

- 4850mAh/11.55V+1300mAh/11.1V dual battery, Large battery support hot-swappable

## Reliability

- Press fingerprintidentification

- IP65 high protection level, 1.22m fall resistant

- In accordance with MIL-STD-810H

## Product Six Views

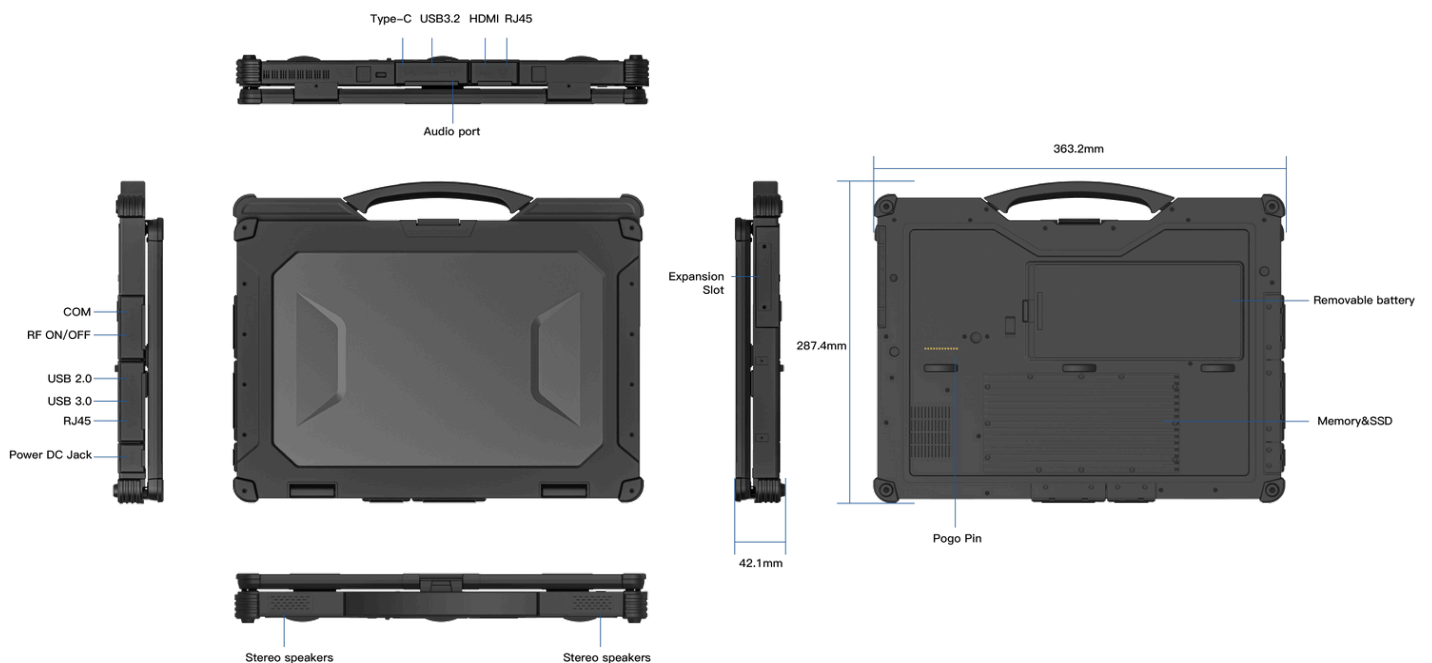

## Specification Parameter

Basic parameters	
Dimension	363.2 x 287.4 x 42.1mm
Weight	2.97kg
Device Color	Black
LCD	14 inch FHD 16:9, 1920x1080, 1000 nits
Touch Panel	Optional 10 point G+G capacitive touch screen Corning® Gorilla® Glass
Camera	Front 5.0MP
I/O	USB3.2 *1, USB3.0 *1, USB2.0 *1, TYPE-C, Support Thunderbolt 4 HDMI 2.0a mini *1, SIM *1, TF *1, DB9 (RS232) *1、RJ45 *2, 3.5mm Standard Earphone Jack *1, DC19V/3.78A Power port *1 Anti-theft Lock Slot *1, Right-side Cooling Vent *1, Left-side expansion slot, optional M.2-2280 PCIe interface *1, supports SSD; Optional: M.2, E-KEY, PCIe interface *1 for custom modules. Optional: 12PIN Pogo Pin (USB & charging) *1
Power	AC100V ~ 240V, Output DC 19V/3.78A 71.82W
Battery (Built-in)	
Capacity	11.1V/1300mAh
Type	Built in Li_polyment,battery loadable
Endurance	1.5hrs (Default 50% volume, 200 lumens brightness, playing 1080P HD video)
Battery (Hot-swappable)	
Capacity	11.55V/4850mAh
Type	Li_polyment, removeable battery
Endurance	7.5hrs (Playing 1080P HD video, Conditions: System in balance mode, 320 lumens, 70 dB at 10cm, WiFi and Bluetooth turned off.)

Performance parameter	
CPU	Intel® Core™ i5-1235U/i7-1255U
OS	Windows 11/10
RAM	16GB/32GB
ROM	256GB SSD
Communication	
WIFI	WiFi 6, 802.11a,b,d,e,g,h,i,k,n,r,u,v,w,ac,ax
Bluetooth	BT5.1 Transmission distance: 10m
2G/3G/4G (Optional)	4G(Optional M.2 European standard) LTE-FDD: B1/3/5/7/8/20/28, LTE-TDD: B38/40/41
5G (Optional)	5G optional M.2, 5G NR: NSA n1/ 2/ 3/ 5/ 7/ 8/ 12/ 13/ 14/ 18/ 20/ 25/ 26/ 28/ 29/ 30/ 38/ 40/ 41/ 48/ 66/ 70/ 71/ 75/ 76/ 77/ 78/ 79/ SA n1/ 2/ 3/ 5/ 7/ 8/ 12/ 13/ 14/ 18/ 20/ 25/ 26/ 28/ 29/ 30/ 38/ 40/ 41/ 48/ 66/ 70/ 71/ 75/ 76/ 77/ 78/ 79 LTE, LTE-FDD B1/ 2/ 3/ 4/ 5/ 7/ 8/ 12/ 13/ 14/ 17/ 18/ 19/ 20/ 25/ 26/ 28/ 29/ 30/ 32/ 66/ 71 LTE-TDD B34/ 38/ 39/ 40/ 41/ 42/ 43/ 48, LAA B46, UMS WCDMA B1/ 2/ 4/ 5/ 8/ 19
GNSS	Supports single GPS or single glonass, default GPS
Reliability	
Operate Temperature	-20 °C ~ 60 °C
Store Temperature	-30 °C ~ 70 °C
Humidity	95% Non-Condensing
Rugged Feature	IP65 certified, MIL-STD-810H certified
Drop Height	1.22m
Data Collection	
NFC	Optional
Fingerprint	SPI fingerprint (power on login)
Keyboard	US Layout Keyboard with Backlight

## Application Range

Various modules and accessories can be selected to meet customers' application in various industries.



Power Maintenance



Equipment Testing



Automobile Manufacturing



Energy Industry